



DP3L series open loop stepping driver

User manual

Wuxi Xinje Electric Co., Ltd.

Data No. D3C04 20220731 1.2

Basic description

- ◆ Thank you for purchasing Xinje DP3L series stepping driver. Please read this product manual carefully before operating.
- ◆ The manual mainly provides the user with relevant guidance and instructions for the correct use and maintenance of the step driver. The manual involves the function, use method, installation and maintenance of the step driver.
- ◆ The contents described in the manual are only applicable to Xinje's DP3L series stepping driver products.

Notice to user

This manual is applicable to the following personnel:

- ◆ The installation personnel of stepper driver
- ◆ Engineering and technical personnel (electrical engineers, electrical operators, etc.)
- ◆ The designer

Before operating or debugging the stepper driver, the above personnel should carefully read the safety precautions section of this manual.

Statement of responsibility

- ◆ Although the contents of the manual have been carefully checked, errors are inevitable and we can not guarantee that they are completely consistent.
- ◆ We will always check the contents of the manual and make corrections in subsequent versions. We welcome your comments.
- ◆ The contents described in the manual are subject to change without prior notice.

Contact us

If you have any questions about the use of this product, please contact the agent and office that purchased the product, or contact Xinje company directly.

- ◆ Tel: 400-885-0136
- ◆ Fax: 0510-85111290
- ◆ Address: No.816, Jianzhu West Road, Binhu District, Wuxi City, Jiangsu Province, China
- ◆ Postcode: 214072
- ◆ Website: www.xinje.com

WUXI XINJE ELECTRIC CO., LTD. Copyright

Without explicit written permission, this information and its contents shall not be copied, transmitted or used. Violators shall be liable for the losses caused. All rights provided in patent license and registration including utility module or design are reserved.

December 2020

Catalog

1. PRODUCT INTRODUCTION	4
1-1. MODEL NAMING RULE	4
1-2. PERFORMANCE	4
1-3. APPLICATION FIELD	4
1-4. ELECTRIC FEATURES	5
1-5. SAFETY PRECAUTIONS	5
2. INSTALLATION AND WIRING	6
2-1. INSTALLATION	6
2-1-1. Outline dimension	6
2-1-2. Installation environment	8
2-2. WIRING	9
2-2-1. Typical wiring diagram	9
2-2-2. Brake wiring	10
2-2-3. Wiring notice	11
3. DRIVER INTERFACE	12
3-1. CONTROL SIGNAL INTERFACE	12
3-1-1. Functions	12
3-1-2. Control signal sequence diagram	12
3-1-3. Control signal circuit	13
3-2. STRONG ELECTRICITY INTERFACE	14
3-2-1. Function	14
3-2-2. Power supply requirements	14
3-3. UPPER COMPUTER COMMUNICATION INTERFACE	14
4. DIP SWITCH	15
4-1. CURRENT SETTING	15
4-1-1. Working current setting	15
4-1-2. Static current setting	16
4-2. SUBDIVISION SETTING	17
4-3. OTHER DIP SWITCH SETTING	18
4-4. PULSE AND DIRECTION INPUT VOLTAGE SETTING	18
5. PROTECTION FUNCTION	19
6. MOTOR SELECTION	19
6-1. MOTOR SELECTION	20
6-2. MOTOR WIRING	20
6-3. POWER SUPPLY AND OUTPUT CURRENT SELECTION	20
6-3-1. Power supply selection	20
6-3-2. Output current setting	21
7. COMMON TROUBLESHOOTING	22

1. Product introduction

1-1. Model naming rule

Take DP3L-11022A3 as an example:

DP3L - 110 22 A 3
① ② ③ ④ ⑤

①	Product Series	DP3L: open-loop stepping driver
②	Driver max peak current	110: 11.3A 80: 8.4A 56: 5.6A 42: 4.2A 22: 2.2A
③	Maximum supply voltage of driver	22: 220V 8: 80V 5: 50V 4: 40V
④	Voltage type	A: AC power supply Vacant: DC power supply
⑤	Driver type	3: Three-phase driver Vacant: Two-phase driver

1-2. Performance

- The performance of the new control algorithm is significantly improved, and the torque of medium and high speed is 10-50% higher than that of the original product.
- The motor performance is improved and the temperature rise is reduced.
- It can drive 4, 6, 8-wire two-phase stepping motor.
- 3-digit switch, 8-gear current can be set.
- 4-digit switch, adjustable 16 gears subdivision.
- Automatic power on and self-tuning function.
- When it is still, the current will be halved automatically, and it can be selected by switch.
- The maximum pulse response frequency is 200kHz.
- With over-current, over-voltage, short circuit and other protection functions.
- External alarm output, maximum output current 50mA, withstand voltage 24VDC.

1-3. Application field

It is suitable for all kinds of small and medium-sized automatic equipment and instruments, such as pneumatic marking machine, labeling machine, cutting machine, laser marking machine, plotter, small engraving machine, CNC machine, handling device, etc. For the small equipment with low vibration, low noise, high precision and high speed expected by users, the effect is especially good.

1-4. Electric features

Item	DP3L-224	DP3L-425	DP3L-565	DP3L-808
Input power supply (VDC)	20-40	20-50	20-50	20-80
Output peak current (A)	0.5-2.2	1-4.2	1.8-5.6	2.7-8.4
Matched motor (base)	42	57	57/86	86
Outline dimension (mm)	92*62*28	110*77*31	110*77*31	135*86.7*35.5
Step pulse frequency (KHz)	200			
Control signal input voltage (VDC)	24			
Storage temperature	-20°C~65°C			
Working temperature	-10°C~50°C			
Humidity	40%~90% RH (No condensation or water droplets)			
Vibration	5.9m/s ² Max			

Item	DP3L-808A	DP3L-11022A3
Input power supply (VAC)	20-80	200-240
Output peak current (A)	2.7-8.4	3.1-11.3
Matched motor (base)	86	86/110/130
Outline dimension (mm)	131*112.2*35	199.5*137*79
Step pulse frequency (KHz)	200	
Control signal input voltage (VDC)	5/24V dial switch	
Storage temperature	-20°C~65°C	
Working temperature	-10°C~50°C	
Humidity	40%~90% RH (No condensation or water droplets)	
Vibration	5.9m/s ² Max	

1-5. Safety precautions

- (1) The drive must be installed and operated by professional technicians!
- (2) The input voltage of the driver must meet the technical requirements!
- (3) It is strictly forbidden to plug the strong current terminal of the driver when the power is on. When the motor stops, there is still a large current flowing through the coil. Plug the strong current terminal will produce a huge instantaneous induced electromotive force, which will burn the driver!
- (4) Before power on, please ensure the correctness and firmness of power cable, motor cable and signal cable connection!
- (5) Avoid electromagnetic interference!

2. Installation and wiring

2-1. Installation

2-1-1. Outline dimension

- DP3L-224

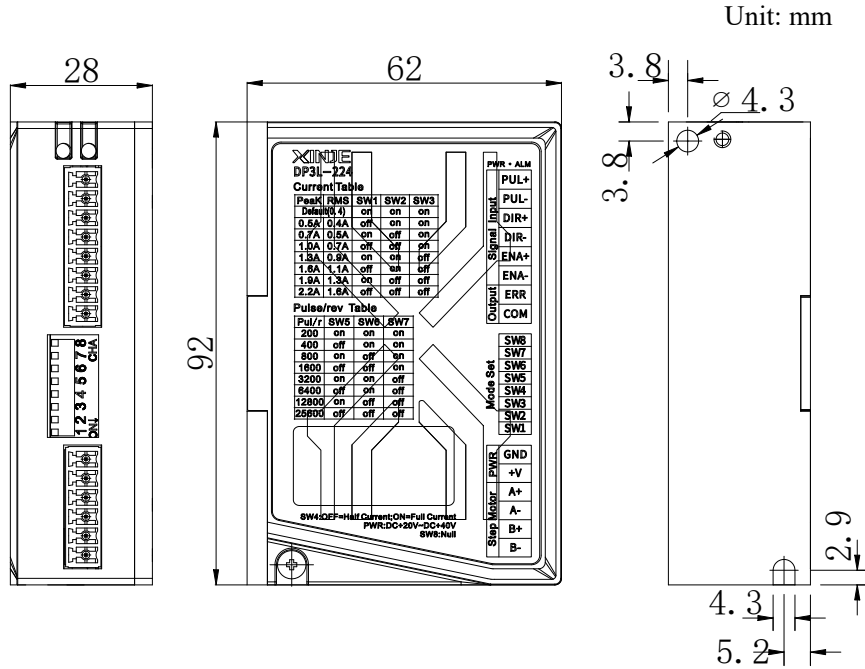

- DP3L-425, DP3L-565

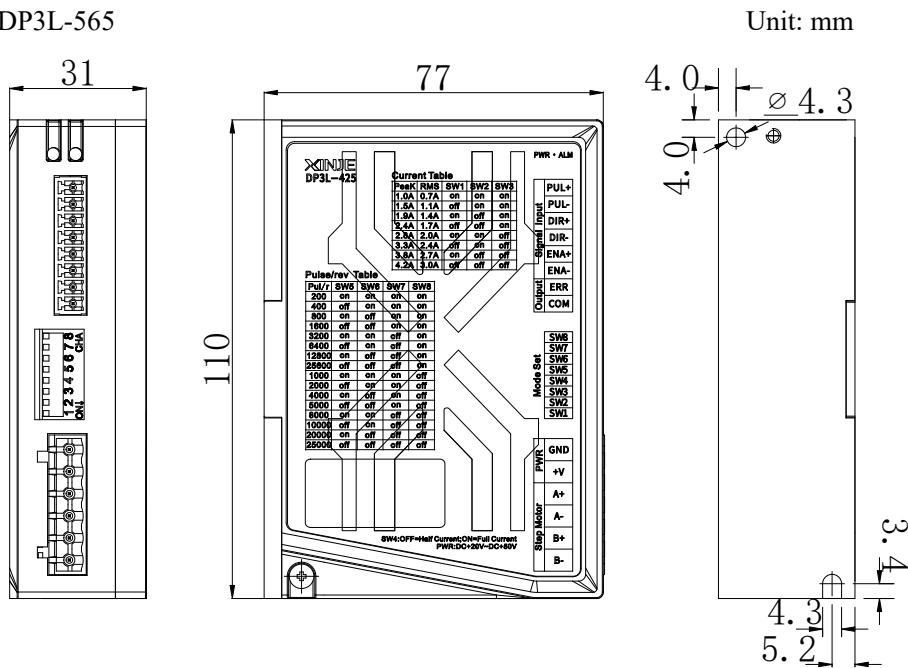

● DP3L-808

Unit: mm

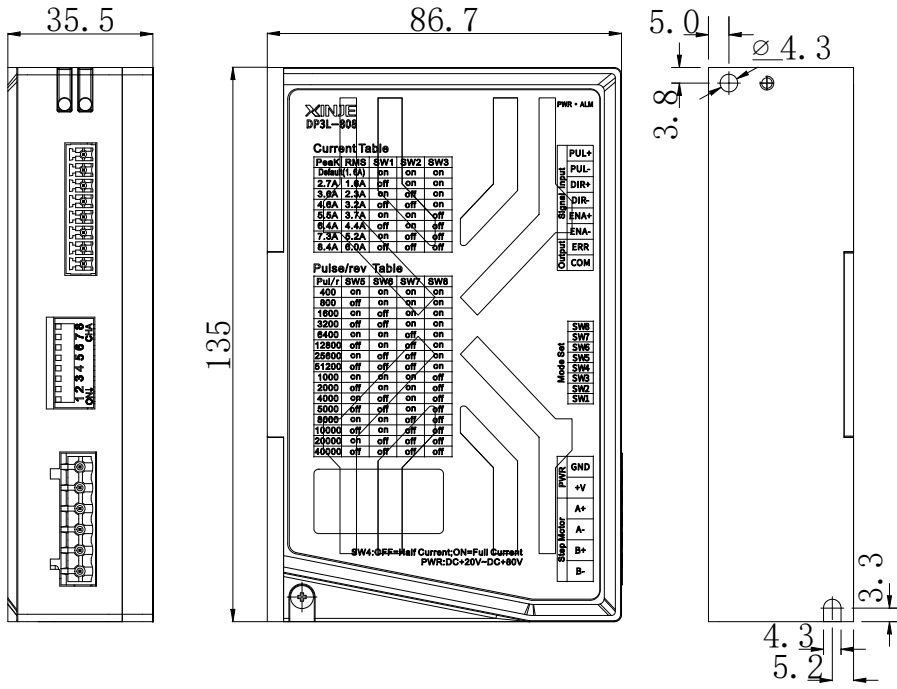

● DP3L-808A

Unit: mm

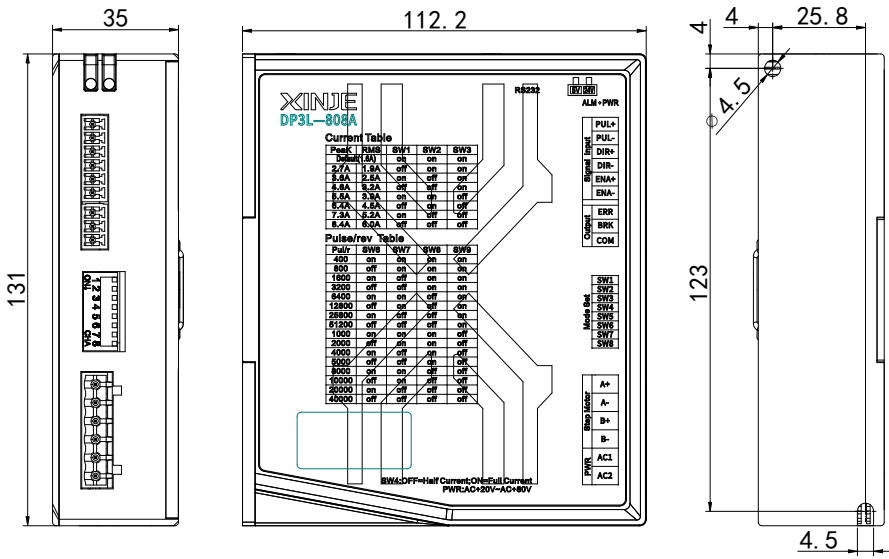

● DP3L-11022A3

Unit: mm

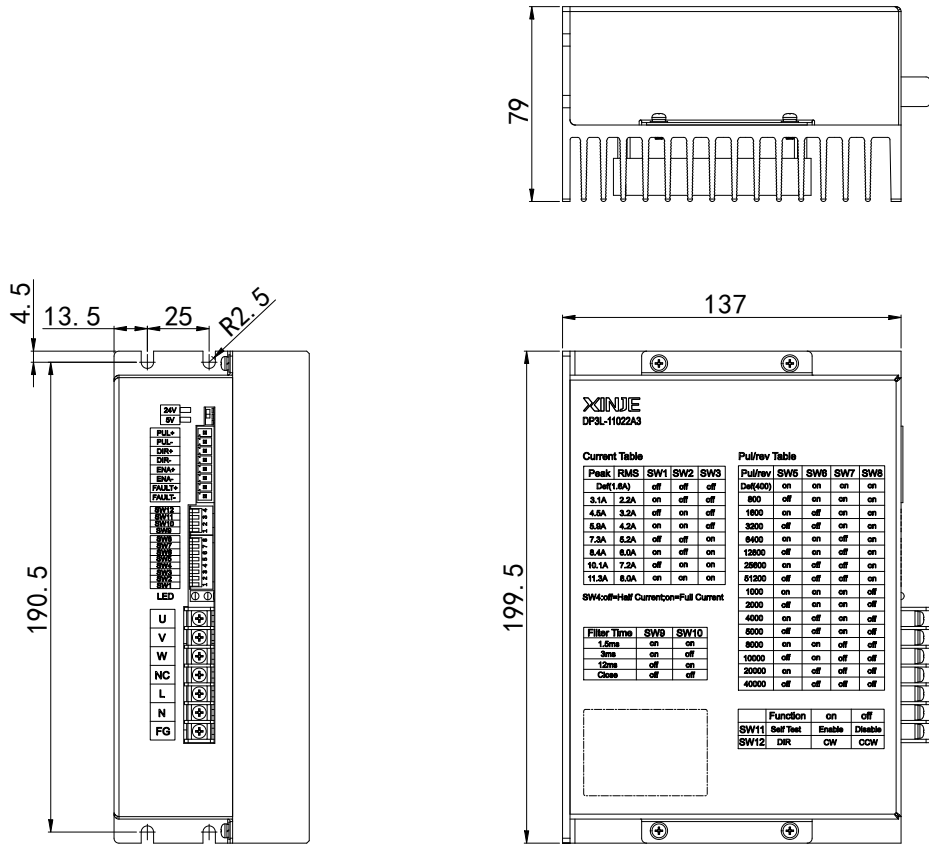

2-1-2. Installation environment

The reliable working temperature of the driver is usually within 60°C and that of the motor is within 80°C. To ensure that the driver works within the reliable working temperature range, the driver should be installed in the electric cabinet with good ventilation and proper protection. If necessary, a fan should be installed near the driver for forced heat dissipation. Avoid being used in dust, oil mist, corrosive gas, high humidity and strong vibration.

2-2. Wiring

2-2-1. Typical wiring diagram

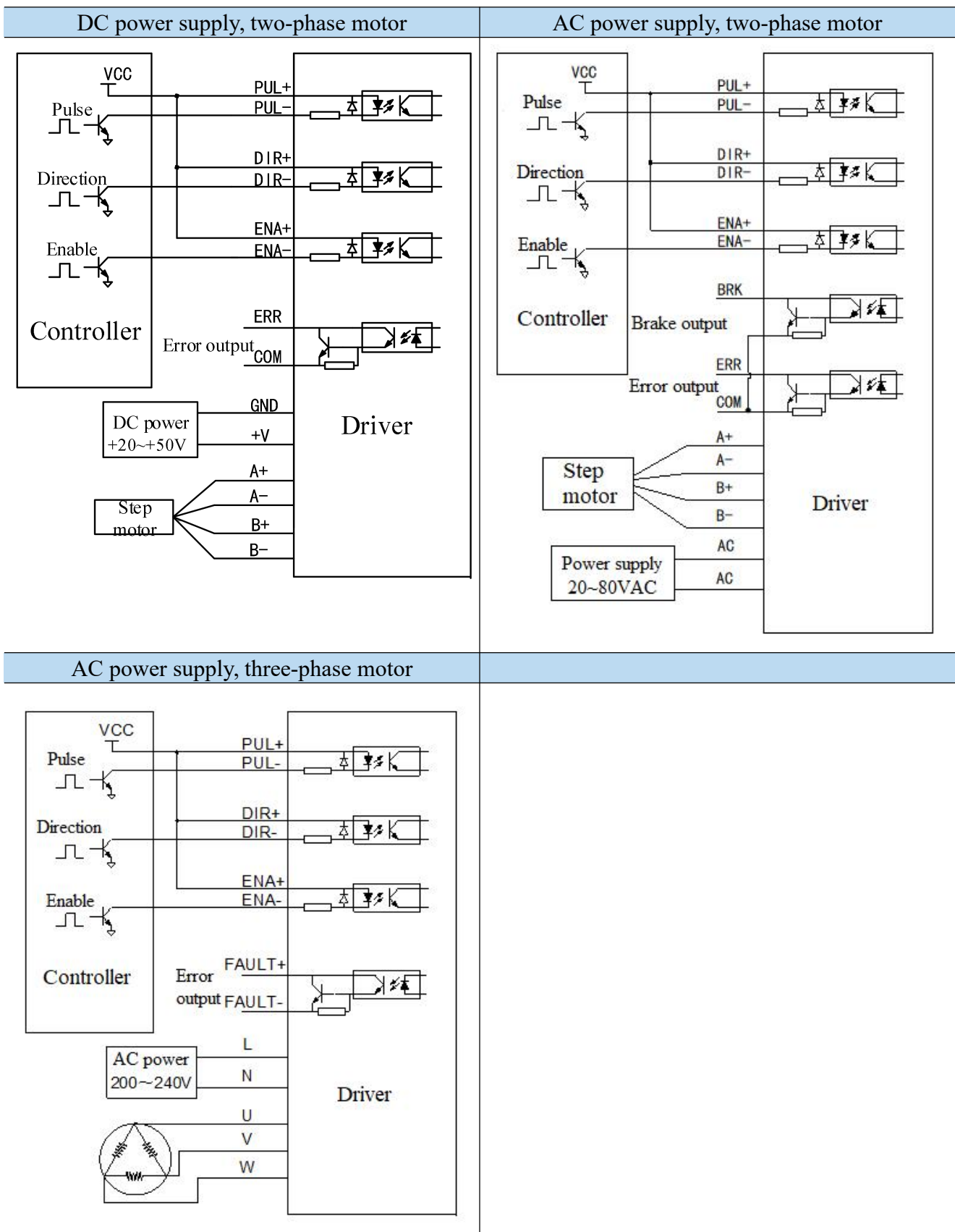

2-2-2. Brake wiring

DP3L-224/425/565/808/11022A3 stepping driver do not contain brake control terminal. When driving the brake type stepping motor, the brake can only be opened or closed by the external power supply.

Connection method of brake wire: the brake wire can be connected to the switching power supply, as shown in Figure A; Or the external intermediate relay controls the holding brake, as shown in Figure B.

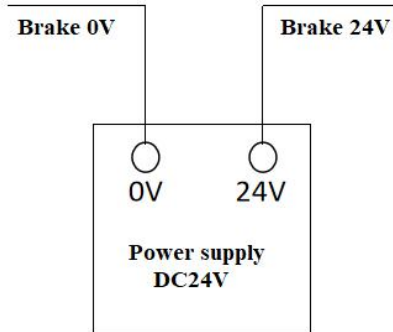

Figure A

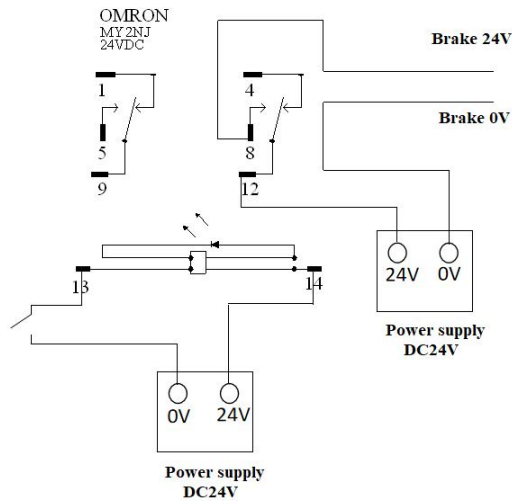

Figure B

DP3L-808A stepping driver has BRK terminal, and the terminal can withstand the maximum current of 500mA, so it can directly control the opening or closing of the holding brake. The wiring is shown in Figure C:

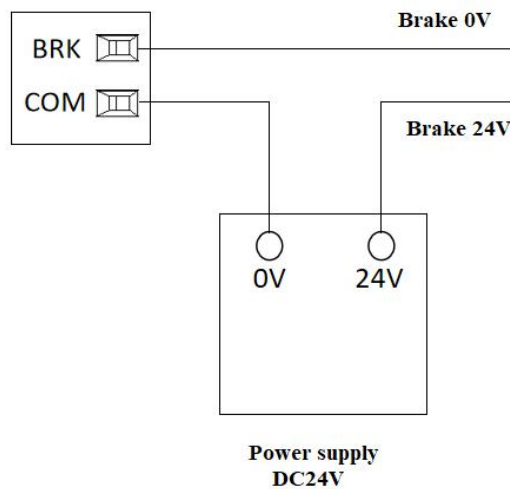

Figure C

Note: Brake 24 V corresponds to the red line; Brake 0 V corresponds to the black line.

2-2-3. Wiring notice

(1) In order to prevent the driver from being interfered, it is suggested that the control signal should use twisted shielded wire, and the shielding layer should be short circuited with the ground wire. Except for special requirements, the shielded wire of the control signal cable should be single ended grounded: one end of the upper computer of the shielded wire should be grounded, and the driver end of the shielded wire should be suspended.

Note: the same machine can only be grounded at the same point. If it is not a real grounding wire, the interference may be serious, and the shielding layer is not grounded at this time.

(2) If a power supply supplies multiple drives, parallel connection should be adopted at the power supply, and chain connection from one to another is not allowed.

(3) It is strictly forbidden to connect the wire head to the terminal after adding tin, otherwise the terminal may be damaged due to overheating due to increased contact resistance.

(4) The wiring head should not be exposed outside the terminal to prevent accidental short circuit from damaging the driver.

(5) The pulse and direction signal cables and motor cables are not allowed to be bound side by side, and it is better to separate them at least 10cm, otherwise the electric power is easy to interfere with the pulse direction signal, causing motor positioning inaccuracy, system instability and other faults.

3. Driver interface

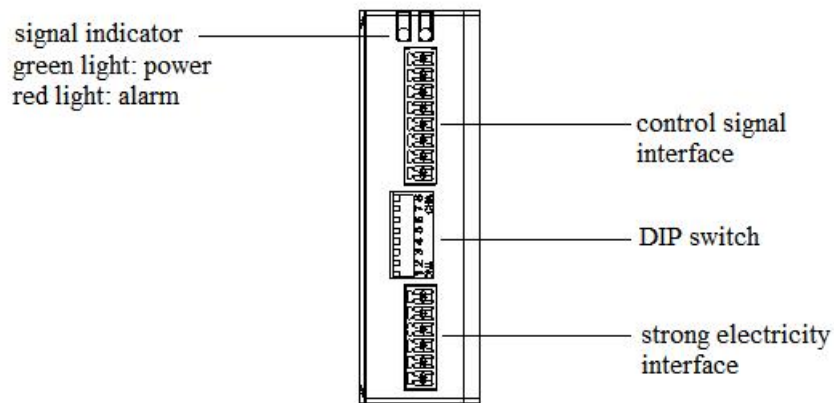

3-1. Control signal interface

3-1-1. Functions

Signal	Function	Explanation
PUL+	Pulse control signal	The rising edge is valid and the signal supports 24 VDC(DP3L-808A/11022A3 support 5V/24V)
PUL -		
DIR+	Direction control signal	High/low level signal corresponds to two directions of motor operation. The signal supports 24 VDC. (DP3L-808A/11022A3 support 5V/24V.) The initial running direction of the motor depends on the wiring of the motor. Exchanging any phase can change the initial running direction of the motor.
DIR-		
ENA+	Enable/release signal	When the signal is on, the driver will cut off the current of each phase of the motor and be in a free state, and the step pulse will not be responded. At this point, the heating and temperature rise of the driver and motor will be reduced. When not in use, the release signal end of the motor to be suspended. Signal supports 24VDC.
ENA -		
BRK,ERR, COM	Alarm, brake output signal	Alarm output, maximum saturation output 50mA, maximum 24VDC, alarm output terminal outputs high level.
FAULT+, FAULT-		Brake output (Note: only DP3L-808A has BRK terminal), which can withstand up to 500mA, the maximum saturated output is 50mA, the maximum is 24VDC, and the brake output terminal outputs high level

3-1-2. Control signal sequence diagram

In order to ensure the reliability of system response, we make the following requirements for each control signal:

- (1) When the signal is at high level, it is required to be effective at 24V, and when the signal is at low level, it is required to be effective at less than 0.5V.
- (2) ENA (enable signal) should be changed to high level at least 3s in advance of DIR (direction signal).
- (3) Ensure that the DIR is created at least 5μs ahead of the PUL falling edge.
- (4) The pulse width should not be less than 1.2μs.

(5) The duration of pulse low level shall not be less than $1.2\mu\text{s}$.

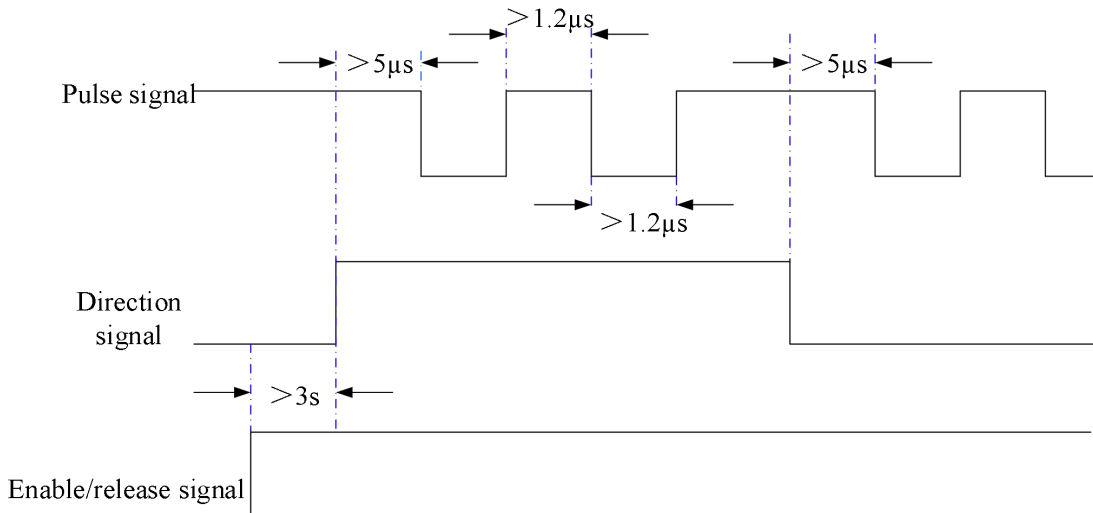

3-1-3. Control signal circuit

The DP3L series allows receiving signals from open collector and PNP output circuits. There are two kinds of connection methods: common cathode and common anode. Now taking PNP output as an example, the schematic diagram of interface circuit is as follows:

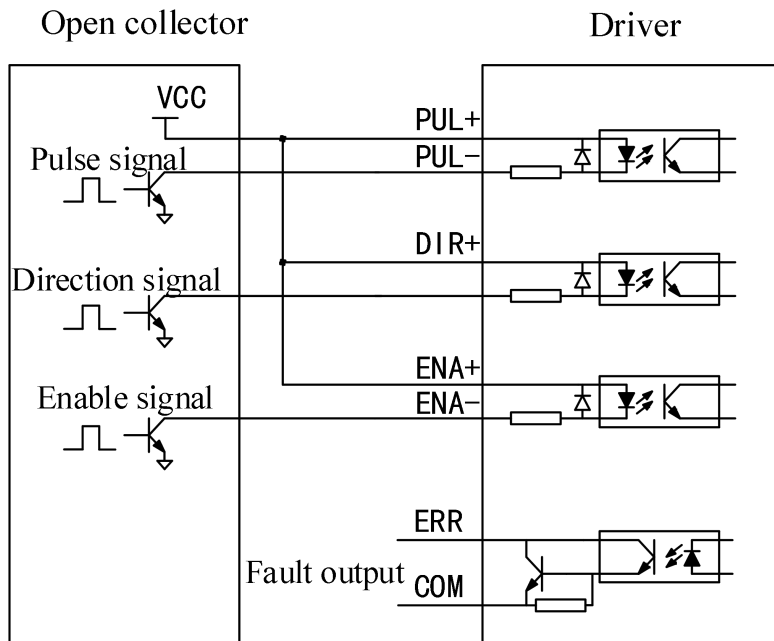

Note: VCC supports 24V.

3-2. Strong electricity interface

3-2-1. Function

Interface	Function	Explanation
GND	DC power supply ground	DC power supply ground
+V	Positive pole of DC power supply	Select the voltage according to the demand
AC, AC	AC power	AC power 20~80V
L, N	AC power	AC power 200~240V
A+, A-	Motor phase A coil	Exchange A+, A-, can change the motor operation direction
B+, B-	Motor phase B coil	Exchange B+, B-, can change the motor operation direction
U, V, W	U,V,W phase	Connected to U, V, W coils of three-phase motor

Note:

DP3L-224 range 20~40VDC: recommended value 24~36VDC;

DP3L-425/565 range 20~50VDC: 57 motor recommended value 24~36VDC. 86 or high speed application recommend 48V.

DP3L-808 range 20~80VDC: recommend 48V and above.

DP3L-808A range 20~80VAC: recommend 48V and above.

DP3L-11022A3 range 200~240VAC, recommend 220V.

3-2-2. Power supply requirements

The power supply voltage can work normally within the standard range. The driver should preferably use non-regulated DC power supply, or use transformer step-down + bridge rectifier + capacitor filter. It is recommended that users use 24V-48V DC power supply to avoid grid fluctuation exceeding the working range of driver voltage. If using regulated switching power supply, the switching power supply output current range should be set to the maximum.

Note:

- (1) Do not reverse the power supply voltage!
- (2) Do not exceed the working range of the power supply to ensure the normal operation of the driver.
- (3) The power supply should be non-regulated DC power supply, and the output capacity of the power supply should be greater than 60% of the set current of the driver.
- (4) If the voltage stabilized switching power supply is used for power supply, the output current range of the power supply should be greater than the working current of the motor.
- (5) In order to reduce the cost, two or three drives can share one power supply, but the power supply should be large enough.

3-3. Upper computer communication interface

DP3L-808A and DP3L-11022A3 driver can be connected to the upper computer through RS232 port to set current, subdivision, function, etc.

4. DIP switch

DP3L-224/425/565/808A series driver adopt 8-bit DIP switch to set subdivision precision, dynamic current and static half current. Detailed description is as follows:

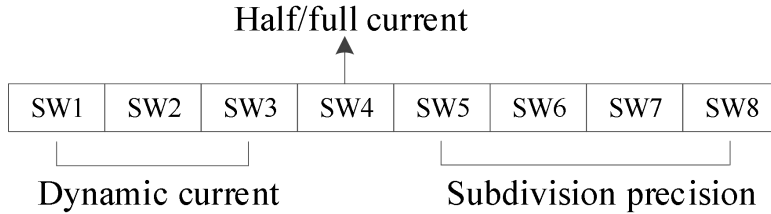

DP3L-11022A3 driver adopt 12-bit DIP switch to set subdivision precision, dynamic current, etc. Detailed description is as follows:

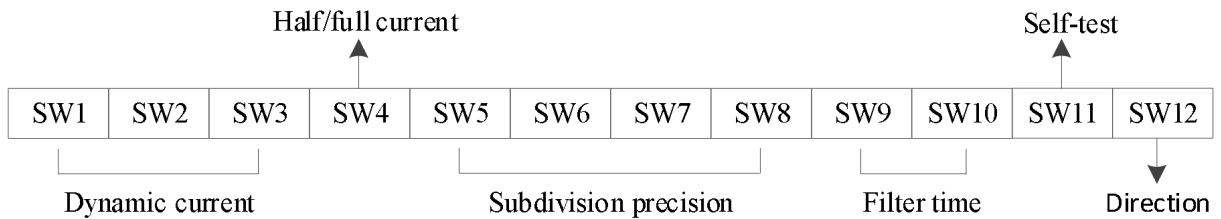

Note: DP3L-224 only has 3-bit DIP switch to set the subdivision, DIP 8 has no detailed definition.

4-1. Current setting

4-1-1. Working current setting

- DP3L-224 current

Peak current	RMS current	SW1	SW2	SW3
Default (0.4A)		On	On	On
0.5A	0.4A	Off	On	On
0.7A	0.5A	On	Off	On
1.0A	0.7A	Off	Off	On
1.3A	0.9A	On	On	Off
1.6A	1.1A	Off	On	Off
1.9A	1.3A	On	Off	Off
2.2A	1.6A	Off	Off	Off

- DP3L-425 current

Peak current	RMS current	SW1	SW2	SW3
1.0A	0.7A	On	On	On
1.5A	1.1A	Off	On	On
1.9A	1.4A	On	Off	On

2.4A	1.7A	Off	Off	On
2.8A	2.0A	On	On	Off
3.3A	2.4A	Off	On	Off
3.8A	2.7A	On	Off	Off
4.2A	3.0A	Off	Off	Off

● DP3L-565 current

Peak current	RMS current	SW1	SW2	SW3
1.8A	1.3A	On	On	On
2.1A	1.5A	Off	On	On
2.7A	1.9A	On	Off	On
3.2A	2.3A	Off	Off	On
3.8A	2.7A	On	On	Off
4.3A	3.1A	Off	On	Off
4.9A	3.5A	On	Off	Off
5.6A	4A	Off	Off	Off

● DP3L-808/808A current

Peak current	RMS current	SW1	SW2	SW3
Default (1.6A)		On	On	On
2.7A	1.6A	Off	On	On
3.6A	2.3A	On	Off	On
4.6A	3.2A	Off	Off	On
5.5A	3.7A	On	On	Off
6.4A	4.4A	Off	On	Off
7.3A	5.2A	On	Off	Off
8.4A	6.0A	Off	Off	Off

● DP3L-11022A3 current

Peak current	RMS current	SW1	SW2	SW3
1.6A (Default)		Off	Off	Off
3.1A	2.2A	On	Off	Off
4.5A	3.2A	Off	On	Off
5.9A	4.2A	On	On	Off
7.3A	5.2A	Off	Off	On
8.4A	6.0A	On	Off	On
10.1A	7.2A	Off	On	On
11.3A	8.0A	On	On	On

4-1-2. Static current setting

SW4 set static current:

SW4 = off: (factory default) after the driver stops receiving the pulse for about 0.4 seconds, the output current is 50% of the peak value (setting half current can reduce the heating of the driver and motor in some applications).

SW4 = on: the output current of the driver is 100% of the peak value when the motor is static.

4-2. Subdivision setting

- DP3L-224 subdivision setting

Pulse/rev	SW5	SW6	SW7
200	On	On	On
400	Off	On	On
800	On	Off	On
1600	Off	Off	On
3200	On	On	Off
6400	Off	On	Off
12800	On	Off	Off
25600	Off	Off	Off

- DP3L-425/565 subdivision setting

Pulse/rev	SW5	SW6	SW7	SW8
200	On	On	On	On
400	Off	On	On	On
800	On	Off	On	On
1600	Off	Off	On	On
3200	On	On	Off	On
6400	Off	On	Off	On
12800	On	Off	Off	On
25600	Off	Off	Off	On
1000	On	On	On	Off
2000	Off	On	On	Off
4000	On	Off	On	Off
5000	Off	Off	On	Off
8000	On	On	Off	Off
10000	Off	On	Off	Off
20000	On	Off	Off	Off
25000	Off	Off	Off	Off

- DP3L-808/808A subdivision setting

Pulse/rev	SW5	SW6	SW7	SW8
400	On	On	On	On
800	Off	On	On	On
1600	On	Off	On	On
3200	Off	Off	On	On
6400	On	On	Off	On
12800	Off	On	Off	On
25600	On	Off	Off	On
51200	Off	Off	Off	On
1000	On	On	On	Off
2000	Off	On	On	Off
4000	On	Off	On	Off
5000	Off	Off	On	Off
8000	On	On	Off	Off

10000	Off	On	Off	Off
20000	On	Off	Off	Off
40000	Off	Off	Off	Off

● DP3L-11022A3 subdivision setting

Pulse/rev	SW5	SW6	SW7	SW8
400 (Def)	On	On	On	On
800	Off	On	On	On
1600	On	Off	On	On
3200	Off	Off	On	On
6400	On	On	Off	On
12800	Off	On	Off	On
25600	On	Off	Off	On
51200	Off	Off	Off	On
1000	On	On	On	Off
2000	Off	On	On	Off
4000	On	Off	On	Off
5000	Off	Off	On	Off
8000	On	On	Off	Off
10000	Off	On	Off	Off
20000	On	Off	Off	Off
40000	Off	Off	Off	Off

4-3. Other DIP switch setting

The function settings of SW9~SW12 dial switches of DP3L-11022A3 are as follows:

DIP No.	Function	ON	OFF	
SW9/SW10	Command Filter time	1.5ms, 3ms and 12ms command filtering time can be set		
		Filter time	SW9	SW10
		Upper computer setting (default 1.5ms)	ON	ON
		3ms	ON	OFF
		12ms	OFF	ON
	Close	OFF	OFF	
SW11	Self test	Run at a constant speed set by parameter P5-03	Disable	
SW12	Direction	CW	CCW	

4-4. Pulse and direction input voltage setting

The voltage of pulse and direction input of DP3L-808A/11022A3 driver can be changed by 5/24V through DIP switch.

Note: If the DIP switch inputs 24V pulse at 5V gear, the driver will be damaged.

5. Protection function

The green LED is the power indicator. When the driver is powered on, the LED is always on; When the drive is powered off, the LED goes out.

The red LED is the fault indicator. When there is a fault, the indicator will flash continuously, then stop for one second, and then flash continuously; When the fault is cleared by the user, the red LED is always off. The continuous flashing times of red LED represent different fault information, and the specific relationship is shown in the table below.

The alarm output terminal outputs high level

Flashing	Fault	Reason and solution
Flash once	Over current or short circuit	The possible causes of alarm are: wiring error, driver short circuit, electromagnetic interference. Check wiring, power on again, clear the alarm. ①DP3L-224 overcurrent value: 4.2A ②DP3L-425 overcurrent value: 14A ③DP3L-565 overcurrent value: 18.6A ④DP3L-808/808A overcurrent value: 23.3A ⑤DP3L-11022A3 overcurrent value: 6A
Flash 2 times continuously	Over voltage	When the driver voltage exceeds the overvoltage value, it will enter the overvoltage protection. At this time, it is necessary to reduce the power supply and power on again to clear the alarm ①DP3L-224 overvoltage value: 45VDC ②DP3L-425 overvoltage value: 60VDC ③DP3L-565 overvoltage value: 85VDC ④DP3L-808/808A overvoltage value: 150VDC ⑤DP3L-11022A3 overvoltage value: can be set
Flash 3 times continuously	Undervoltage	When the bus voltage of the driver is lower than 200VAC (DP3L-11022A3), the undervoltage protection will enter. The possible alarm causes are: the power supply voltage is too low or the fluctuation is too large.
Flash 4 times continuously	Motor open circuit or poor contact	The motor state is detected when the parameters of the power on motor are self-tuning. During the operation, the motor disconnection and other information are not detected. Check wiring, power on again, clear the alarm

Note: since the driver does not have the function of power supply positive and negative reverse connection protection, please confirm the power positive and negative pole wiring is correct before power on.

If the positive and negative poles are connected reversely, the fuse in the driver will be burnt out.

6. Motor selection

DP3L-224/425/565/808/808A can be used to drive 4, 6, 8-wire two-phase, four-phase hybrid stepping motor, with a step angle of 1.8 degree and 0.9 degree. DP3L-11022A3 can be used to drive 86,110,130

When selecting the motor, the torque and rated current of the motor are the main factors. The torque is mainly determined by the motor size. The torque of the motor with large size is larger. The current is mainly related to inductance, and the high speed performance of small inductor motor is good, but the current is large.

6-1. Motor selection

When selecting the motor, three factors should be determined: load torque, transmission ratio and working speed range.

The output of the motor is calculated by the following formula: $T(\text{motor}) = C(J\varepsilon + T(\text{load}))$.

C: safety factor, recommended value 1.2-1.4.

J: Moment of inertia of load.

ε : Maximum angular acceleration of load.

T load: The maximum load torque, including effective load, friction, transmission efficiency and other resistance torque.

6-2. Motor wiring

For 6-wire and 8-wire stepping motors, the connection methods of different coils are quite different, as shown in the figure below:

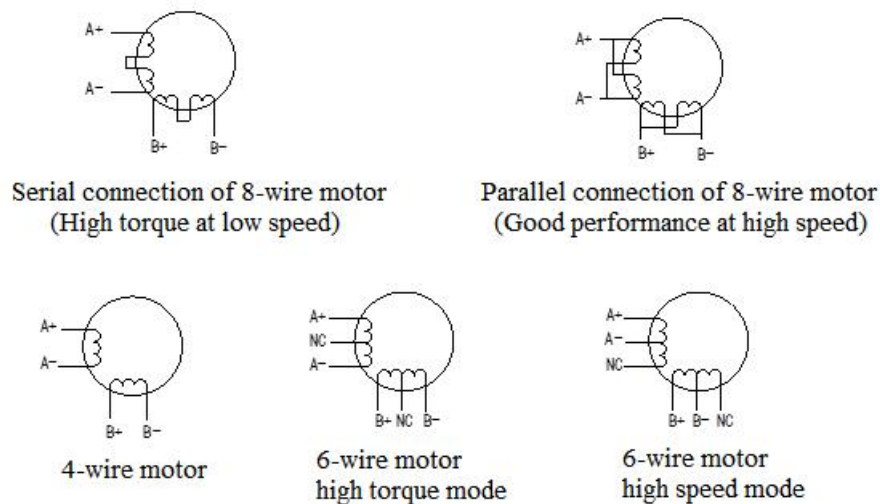

The method to judge whether the series connection or parallel connection of stepper motor is correct or not: rotate the motor shaft directly by hand without connecting the driver. If it can rotate easily and evenly, it means that the wiring is correct. If it encounters large resistance and uneven and accompanied by certain sound, it means that the wiring is wrong.

6-3. Power supply and output current selection

6-3-1. Power supply selection

Generally speaking, the higher the power supply voltage, the greater the torque of the motor at high speed. The more step loss can be avoided at high speed. But on the other hand, too high voltage will lead to over-voltage protection, more motor heating, and even damage the driver. When the motor works under high voltage, the vibration of the motor at low speed will be larger.

6-3-2. Output current setting

For the same motor, the higher the current setting value is, the greater the motor output torque is. However, when the current is high, the heating of motor and driver is also serious. The heating value is not only related to the current setting value, but also related to the type of movement and residence time.

The output peak current of our optional four wire motor is set to be equal to or slightly less than the rated current of the motor. But the best value in practical application should be adjusted on this basis. In principle, if the temperature is very low ($< 40^{\circ}\text{C}$), the current setting value can be appropriately increased to increase the motor output power (torque and high-speed response). If the temperature rise of the motor is too high ($> 70^{\circ}\text{C}$), the current setting value should be reduced. Therefore, the general situation is to set the current to the value when the motor is warm but not hot for a long time.

7. Common troubleshooting

Fault	Reason	Solution
The power light doesn't work	Power supply system error	Check the power supply circuit
	Low supply voltage	Increase the power supply voltage
The motor doesn't work	The current setting is too small	Set suitable current
	The subdivision is too large	Set suitable subdivision
	Protection circuit action	Power on again
	Release signal is low	Do not connect this signal
	Not power on	Power on again
	Motor wiring error	Check the wiring
	No pulse signal input	Check the pulse cable and signal voltage
Motor direction is error	Line failure	Check the circuit
	Phase order is reversed	Interchange the wiring of any phase
Alarm light is on	Motor cable connection error	Wiring again
	Voltage too high or too low	Adjust the power supply voltage
	Motor or driver damaged	Check the motor and driver
Motor torque is small	Acceleration is too fast	Decrease the acceleration value
	Motor torque too small	Select the model again
	Voltage too low or current too small	Properly increase the voltage and current

XINJE



WUXI XINJE ELECTRIC CO., LTD.

No.816, Jianzhu West Road, Binhu District,

Wuxi City, Jiangsu Province, China

Tel: 400-885-0136

Fax: (510) 85111290

www.xinje.com