



LF series remote IO

User manual

WUXI XINJE ELECTRIC CO., LTD.

Data No. : PR 02 20231208 1.0

Basic notes

- ◆ Thank you for purchasing the Xinje LF series remote IO and XF series expansion modules.
- ◆ This manual mainly introduces the hardware characteristics of LF series couplers and XF series expansion modules.
- ◆ Before using the product, please read this manual carefully and operate on the premise of fully understanding the contents of the manual.
- ◆ For the introduction of software and programming, please refer to the relevant manuals.
- ◆ Please deliver this manual to the end user.

User instructions

- ◆ Only operators with certain electrical knowledge can carry out wiring and other operations on the product. If there are any unknown cases, please consult our technicians.
- ◆ The examples listed in the manual and other technical materials are only for users' understanding and reference, and don't guarantee certain actions.
- ◆ When using this product in combination with other products, please confirm whether it complies with relevant specifications and principles.
- ◆ When using this product, please confirm whether it meets the requirements and is safe.
- ◆ Please set up backup and safety functions by yourself to avoid possible machine failure or loss caused by the failure of this product.

Statement of responsibility

- ◆ Although the contents of the manual have been carefully checked, errors are inevitable, and we can't guarantee complete consistency.
- ◆ We will often check the contents of the manual and correct them in subsequent versions. We welcome your valuable comments.
- ◆ Please understand that the contents described in the manual are subject to change without notice.

Contact method

If you have any questions about the use of this product, please contact the agent and office who purchased the product, or directly contact Xinje company.

- ◆ Telephone: 400-885-0136
- ◆ Fax: 0510-85111290
- ◆ Address: 4th floor, building 7, creative industry park, No. 100, Dicui Road, Wuxi, China
- ◆ Post code: 214072
- ◆ Website: www.xinje.com

WUXI XINJE ELECTRIC CO., LTD. All rights reserved

This material and its contents shall not be copied, transmitted or used without explicit written permission. Violators shall be liable for the losses caused. All rights provided in the patent license and registration including utility modules or designs are reserved.

November, 2023

Safety precautions

(Please make sure to read before use)

The potential problems that may arise during the use of the product are basically listed in safety precautions, and are all indicated in two levels: attention and danger. For other unfinished matters, please follow the basic electrical operating procedures.



Note

When used incorrectly, it may pose a danger and may result in moderate or minor injuries, as well as potential property damage.



Danger

When used incorrectly, it may pose a danger, causing personal injury or serious injury, as well as potentially causing serious property damage.

● Confirmation upon receiving the product



Note

1. Damaged controllers, controllers with missing components, or controllers with models that don't meet the requirements, please don't install them.
There is a risk of injury.

● System design of the product



Danger

1. Please design a safety circuit outside the controller to ensure that the entire system can operate safely in case of abnormal controller operation.
There is a risk of causing misoperation and malfunction.



Note

1. Please don't tie the control wiring and power wiring together. In principle, they should be separated by 10cm.
May cause misoperation and product damage.

● Product installation



Danger

1. Before installing the controller, be sure to disconnect all external power sources.
There is a risk of electric shock.



Note

1. Please install and use this product under the environmental conditions specified in the general specifications of the manual.
Don't use in damp, high temperature, dusty, smoke, conductive dust, corrosive gases, flammable gases, as well as places with vibration and impact.
It may cause electric shock, fire, misoperation, product damage, etc.
2. Don't directly touch the conductive parts of the product.
May cause misoperation or malfunction.
3. Please use DIN46277 guide rail to fix this product and install it on a flat surface.
Incorrect installation may cause misoperation and product damage.
4. When processing screw holes, please don't allow cutting powder or wire debris to fall into the product casing.
May cause misoperation or malfunction.
5. When connecting the expansion module with an expansion cable, please confirm that the connection is tight and the contact is good.
May lead to poor communication and misoperation.
6. When connecting peripheral devices, expansion devices, batteries, etc., please make sure to power off the operation.
May cause misoperation or malfunction.

● Product wiring



Danger

1. Before wiring the controller, be sure to disconnect all external power sources.
There is a risk of electric shock.
2. Please correctly connect the AC or DC power supply to the dedicated power terminal of the controller.
Connecting the wrong power supply may burn out the controller.
3. Before powering on and running the controller, please cover the cover plate on the terminal block.
There is a risk of electric shock.



Note

1. Please use a power supply within the voltage range to power the coupler or module, otherwise it may cause damage to the product.
2. Please use a 2mm² wire to perform the third type of grounding on the grounding terminals of the controller and expansion equipment, and don't connect them to the common grounding of the strong current system.
May cause malfunctions, product damage, etc.
3. Don't perform external wiring on empty terminals.
May cause misoperation and product damage.
4. When processing screw holes, please don't allow cutting powder or wire debris to fall into the product casing.
May cause misoperation, malfunction, etc.
5. When using wires to connect terminals, please be sure to tighten them tightly and don't let the conductive parts come into contact with other wires or terminals.
May cause misoperation and product damage.

● Operation and maintenance of products



Danger

1. After powering on the controller, don't touch the terminals.
There is a risk of electric shock.
2. Don't wire or disassemble terminals with electricity.
There is a risk of electric shock.
3. Before making changes to the program in the controller, please make sure to stop it first.
May cause misoperation.



Note

1. Don't disassemble or assemble this product without authorization.
May cause damage to the product.
2. Please plug and unplug the connecting cable in case of power outage.
May cause damage to cables and cause misoperation.
3. Don't perform external wiring on empty terminals.
May cause misoperation and product damage.
4. When disassembling expansion devices, peripheral devices, and batteries, please power off first.
May cause misoperation, malfunction, etc.
5. When the product is discarded, please dispose of it as industrial waste.
6. Before installing the device, please make sure to turn off the power. If the power is not turned off, the device may malfunction or be damaged. When disassembling the XF-I/O unit, be sure to turn off the CPU unit or intermediate power supply.
May cause malfunctions, product damage, etc.
7. Don't stick adhesive tape or labels on both sides of the device or at the golden finger. Adhesive tape or labels may affect the normal vertical sliding installation of the module unit. The residue of the adhesive tape or debris may adhere to the pins of the XF- I/O bus connector.
May cause misoperation, malfunction, etc.
8. Don't touch the XF- I/O bus connector on the device as sweat and dust may adhere to the connector or golden fingers.
This may cause malfunctions.

NG

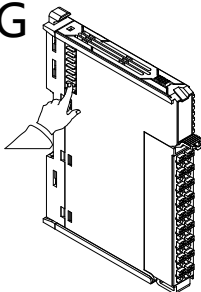

NG

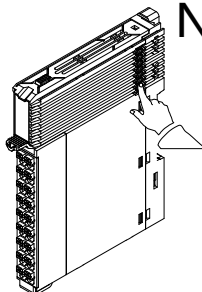

9. Don't use ink to write on the device in the area shown in the picture.
This may cause malfunctions.

Preface

Sincerely thank you for purchasing the XF-IO series of Xinje programmable controllers.

This manual is convenient for users to understand and use the necessary precautions, specifications, functions, and other content when using XF-IO units.

Before use, it is important to thoroughly read this manual and related manuals, and correctly use this product based on a thorough understanding of the functionality/performance of the XF-IO series expansion modules.

Catalog

Safety precautions	I
PREFACE	IV
CATALOG	V
1. DOCUMENT GUIDE	1
1.1 RELATED MANUAL.....	1
2. TERMINOLOGY	2
3. COUPLER UNIT	3
3.1 NAMING RULES.....	3
3.2 ETHERCAT COUPLER LFC3-AP	4
3.2.1 Overview.....	4
3.2.2 Module view	4
3.2.3 General specification	6
3.2.4 Technical specifications	7
3.2.5 Installation&Wiring	8
3.2.6 Use cases.....	10
3.3 PROFINET COUPLER LFP3-AP	19
3.3.1 Overview.....	19
3.3.2 Module view	19
3.3.3 General specification	21
3.3.4 Technical specifications	22
3.3.5 Installation&Wiring	22
3.3.6 Use Cases.....	24
4. DIGITAL QUANTITY MODULE UNIT	35
4.1 NAMING RULES.....	35
4.2 DIGITAL INPUT UNIT XF-E16X	36
4.2.1 Overview.....	36
4.2.2 Module view	36
4.2.3 General specification	37
4.2.4 Technical specifications	38
4.2.5 Installation&Wiring	39
4.2.6 Usage of XF-E16X and LFC3-AP	43
4.2.7 Usage of XF-E16X and LFP3-AP	46
4.3 DIGITAL OUTPUT UNIT XF-E16YT.....	48
4.3.1 Overview.....	48
4.3.2 Module view	48
4.3.3 General specification	49
4.3.4 Technical specifications	50
4.3.5 Installation&Wiring	51

4.3.6 Usage of XF-E16Y and LFC3-AP	55
4.3.7 Usage of XF-E16Y and LFP3-AP	59
4.4 DIGITAL INPUT OUTPUT HYBRID UNIT XF-E8NX8YT	61
4.4.1 Overview.....	61
4.4.2 Module view	61
4.4.3 General specification	62
4.4.4 Technical specifications	63
4.4.5 Terminal definition&Wiring	64
4.4.6 Usage of XF-E8NX8YT and LFC3-AP.....	68
4.4.7 Usage of XF-E8NX8YT and LFP3-AP	72
5. ANALOG MODULE UNIT	75
5.1 NAMING RULES	75
5.2 ANALOG INPUT UNIT XF-E4AD	76
5.2.1 Overview.....	76
5.2.2 Module view	76
5.2.3 General specification	77
5.2.4 Technical specifications	78
5.2.5 Terminal definition&Wiring	80
5.2.6 Usage of XF-E4AD and LFC3-AP.....	84
5.2.7 Usage of XF-E4AD and LFP3-AP	92
5.3 ANALOG OUTPUT UNIT XF-E4DA	97
5.3.1 Overview.....	97
5.3.2 Module view	97
5.3.3 General specification	98
5.3.4 Technical specifications	99
5.3.5 Terminal definition&Wiring	101
5.3.6 Usage of XF-E4DA and LFC3-AP	105
5.3.7 Usage of XF-E4DA and LFP3-AP.....	110

1. Document Guide

1.1 Related manual

1) CPU unit

Manual name	Main content
User Manual for XSF Series Programmable Controllers [Hardware section]	Mainly records the hardware specifications and maintenance information of XSF series CPU units
XS series PLCopen standard controller user manual [Instruction section] (XS studio)	Mainly recorded in the XS series instruction section
XS series PLCopen standard controller user manual [Software section] (XS studio)	Mainly records the operation and corresponding functions of XS Studio programming software

2) I/O unit

Manual name	Main content
XF Series Expansion Module User Manual	Mainly records the product specifications and maintenance information of the XF series IO unit

2. Terminology

In this manual, unless otherwise specified, the following terms will be used for explanation.

Terminology	Explanation
Coupler	XF series expansion module adapter, supporting EtherCAT and PROFINET bus protocols.
Power module unit	General term for XF series power modules.
IP20	Protection level according to DIN 40050: protection against finger contact and intrusion of particles with a diameter greater than 12mm.
Backplane bus	The backplane bus is a serial data bus used by various modules to communicate with each other. The backplane bus is also used to provide some necessary power for each module. Each module is connected through a bus connector.

3. Coupler unit

In this chapter, the specifications, appearance dimensions, and usage methods of each bus coupler unit are introduced.

3.1 Naming rules

L F C 3 — AP
① ② ③ ④ ⑤

①	Series name	L:	Remote I/O series
②	Refers to the extension module	F:	Indicating compatibility with XF series right expansion module
③	Bus type	C:	EtherCAT bus
		P:	Profinet bus
		E:	EtherNet/IP bus (In development, please stay tuned)
④	Ethernet bandwidth	3:	100M
⑤	Unit type	AP:	Coupler unit

3.2 EtherCAT coupler LFC3-AP

3.2.1 Overview

LFC3-AP coupler unit supports EtherCAT bus communication protocol, a single adapter module can connect up to 32 XF series I/O modules, it can achieve seamless connection with mainstream PLCs such as XINJE, Beckhoff, Omron, and Keyence.

- Compact structure, saving installation space.
- Minimum support for 250us DC synchronization.
- Support firmware upgrade for network ports.
- Support hardware static station number setting.
- High speed bus microsecond response.
- Maximum support for 32 expansion modules.

■ Module version

Hardware version	Firmware version	Function
H2.0.0	V2.0.0	Basic functions for the first official production

3.2.2 Module view

1) Description of each section



No.	Name	No.	Name
①	DC24V power supply terminal	②	Status indicator
③	EtherCAT IN port	④	EtherCAT OUT port
⑤	Guide rail buckle	⑥	Used to set ECAT static station numbers, ranging from 1 to 255. When the station number is 0, the main station automatically assigns a station number

2) System indicator

Abbreviation	Explanation
PWR	Power indicator light, lit when the power system is normal
RUN	Running indicator light, lit up when the system is running normally
ERR	System malfunction indicator light, lit up when system malfunction occurs
SF	Module error indicator light

● RUN indicator

RUN indicator	State	Explanation
Extinguish	INT	Initialize
Flash (2Hz)*2	PRE-OP	Trial running
Flash (1Hz)*1	SAFE-OP	Safe run
Light	OP	Running state
Flash (10Hz)*3	BOOTSTRAP or loading the EEPROM	Download EEPROM

● ERR indicator

ERR indicator	Explanation	Processing method
Extinguish	No Error	
Flash (10Hz)*1	EEPROM load error	<ol style="list-style-type: none"> 1. Power on again. 2. Reflash EEPROM.
Single flash*4	AL status register error	<ol style="list-style-type: none"> 1. Check the configuration of the main station and upper computer. 2. Reactivate configuration.
Double flashing*5	Process data watchdog timeout	<ol style="list-style-type: none"> 1. Check if the connection between the slave station and the master station is intact. 2. Check if the main station reports any errors.
Light	PDI watchdog timeout	<ol style="list-style-type: none"> 1. Check if the connection between the slave station and the master station is intact. 2. Check if the main station reports any errors. 3. Check if there is excessive interference on site. 4. Power on again.

● SF indicator

SF indicator	Explanation	Processing method
Extinguish	Expansion module is normal	
Single flash*4	Expansion module failure	<ol style="list-style-type: none"> 1. Check the module power supply. 2. Check if the module is faulty. Replace the module. 3. Check the external channel wiring status.

SF indicator	Explanation	Processing method
Light	Detect configuration topology mismatch with reality	<ol style="list-style-type: none"> 1. Check the communication interface contact of the expansion module or restart the entire system. 2. Check if the module in the corresponding slot is powered off or unplugged. 3. Check the communication interface contact of the expansion module or restart the entire system.

- *1: A square wave with a duty cycle of 50% and a frequency of 1Hz.
- *2: A square wave with a duty cycle of 50% and a frequency of 2Hz.
- *3: A square wave with a duty cycle of 50% and a frequency of 10Hz.
- *4: Single flash as shown in the figure below:

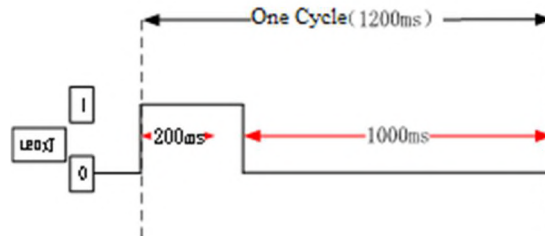

- *5: Double flashing as shown in the figure below:

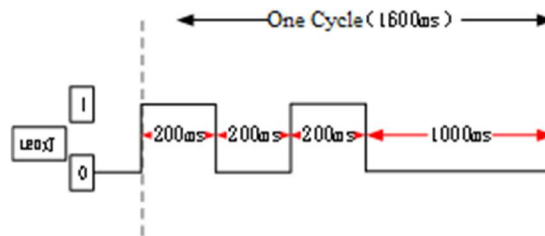

3.2.3 General specification

General specification		
Project	Specifications	
Operating temperature	Maximum temperature	55°C
	Minimum temperature	-20°C
Transportation/Storage temperature	Maximum temperature	70°C
	Minimum temperature	-40°C
Environmental humidity (including operation/storage)	Upper limit	95%
	Lower limit	10%

General specification	
Project	Specifications
IP code	IP20
Anti vibration	Compliant with IEC61131-2 Under intermittent vibration (frequency 5-9Hz, constant amplitude 3.5mm peak displacement) and (frequency 9-150Hz, constant acceleration 1.0g peak acceleration) Under continuous intermittent vibration (frequency 5-9Hz half amplitude 1.75mm displacement) and (frequency 9-150Hz constant acceleration 0.5g constant frame amplitude) Scan 10 times in X, Y, and Z directions
Impact resistance	Complies with IEC61131-2 standard The impact strength is 15G (peak) and the duration is 11ms. It is applied to three mutually perpendicular axes, and each axis is impacted 3 times (a total of 18 impacts)
Using environment	Non corrosive gas
Using altitude	0-2000 m
Overvoltage level	II: Complies with IEC61131-2
Pollution level	2: Complies with IEC61131-2
Anti interference EMC	Complies with IEC 61131-2 IEC61000-6-4 Type B
Related certifications	CE

3.2.4 Technical specifications

Project	Specifications
Bus type	EtherCAT
Rated input voltage	DC24V
Voltage allowable range	DC21.6-26.4V
Input current	120mA DC2V
Allow instant power outage time	10ms DC24V
Impulse current	10A DC26.4V
Power protection	Anti reverse connection protection, overcurrent protection, surge absorption
Single AP process data	Input maximum 1024 bytes, output maximum 1024 bytes
Network interface	2 RJ45 ports
Physical layer	100BASE-TX
Synchronization cycle	Support 250us, 500us, 1000us, 2000us, 4000us
Transmission distance	Less than or equal to 100m between two nodes
Transmission medium	Over five categories and above
Topological structure	Linear or star shaped (external branching device)
Number of expansion modules	Supports 32 modules
Firmware upgrade	Support
Station number setting	Configuration by dial switch (1-255) or allocation by main station

3.2.5 Installation & Wiring

3.2.5.1 Appearance dimension diagram

(Unit: mm)

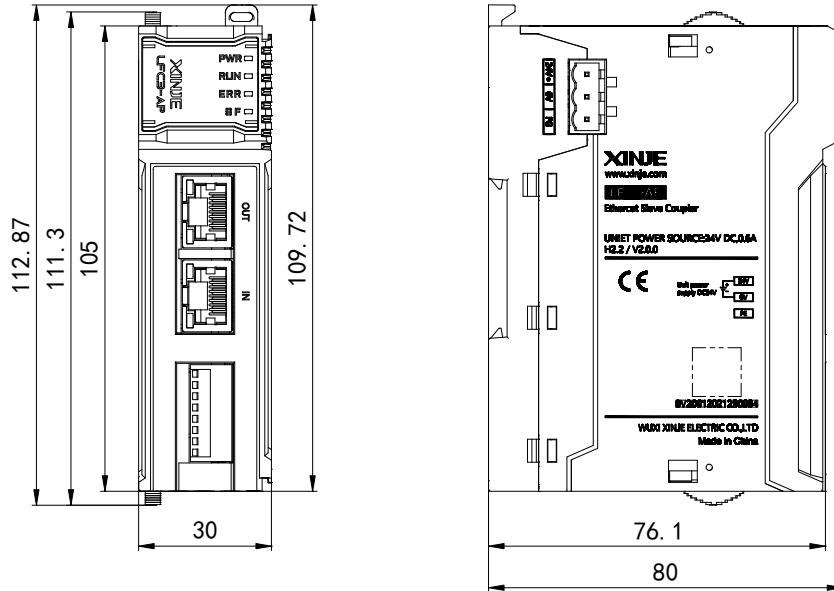

3.1.5.2 Installation method

The module is installed using DIN rails, which must comply with the IEC 60715 standard (35mm wide, 1mm thick). The dimension information is shown in the following figure, and the unit is (mm).

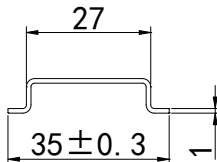

Note

When the module is installed on a non recommended DIN rail, the DIN rail latch may not lock properly.

3.1.5.3 Installation environment

This product can be installed in four positions (i.e. installation direction): horizontal, vertical, top of cabinet, and bottom of cabinet, it is recommended to install in a horizontal direction, and the heat dissipation design should be through natural convection, to ensure normal ventilation and heat dissipation, and to reserve sufficient wiring space, the minimum gap must be left around this product, as shown in the following figure:

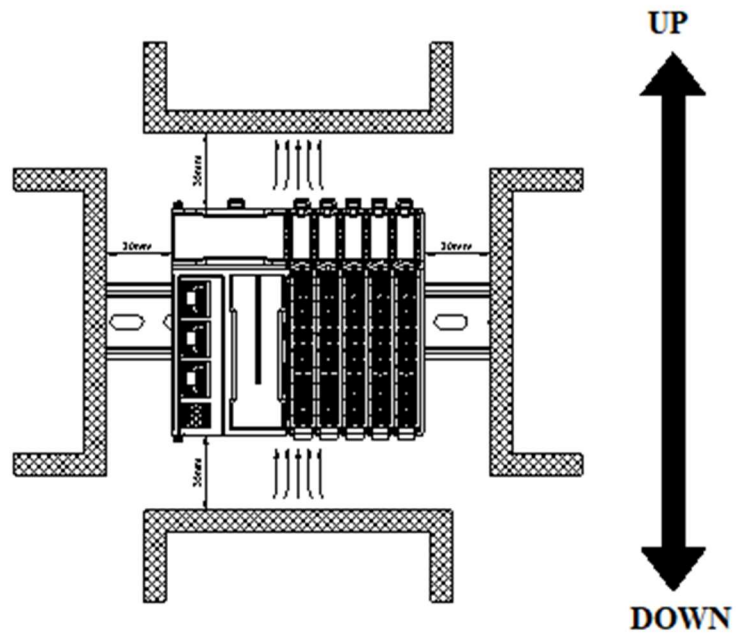

If there is a high-temperature heat source equipment (heater, transformer, high resistance, etc.) around this product, at least 100mm gap should be left between it and the high-temperature heat source equipment.

3.2.6 Use cases

3.2.6.1 LFC3-AP connected to XINJE XDH/XLH/XG2

1. Add the ".xml" file corresponding to LFC3-AP. Open the XINJE XDPPro programming software and right-click on "PLC Master" in EthercatMaster, click "Add Device" and click "Import Device" in the device library.

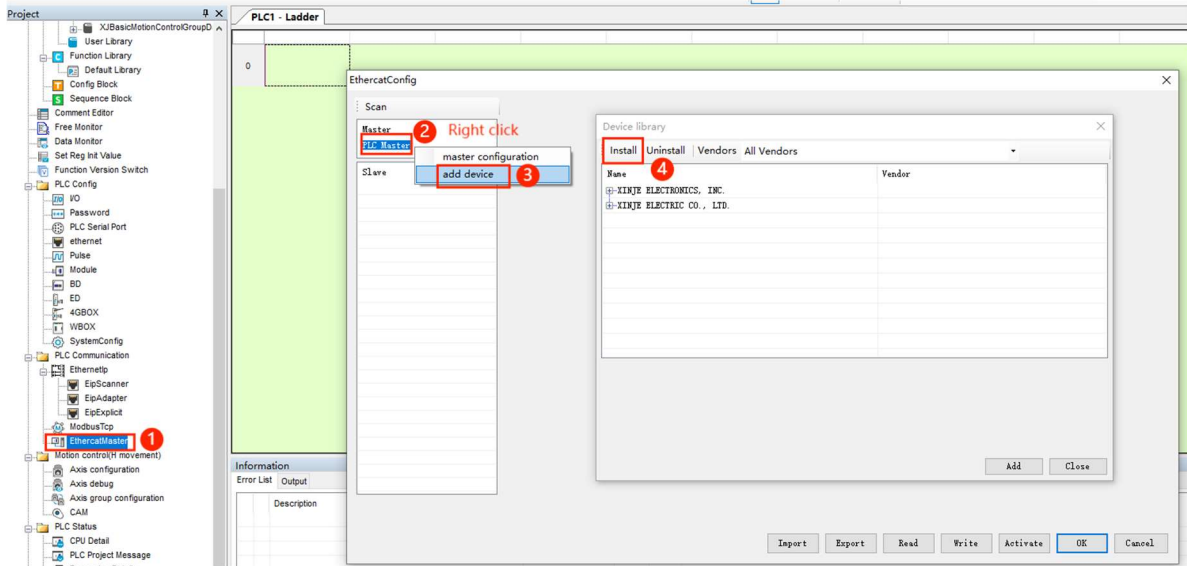

2. Find the directory where the LFC3-AP xml file is located, select it, and click "Open" to complete the addition.

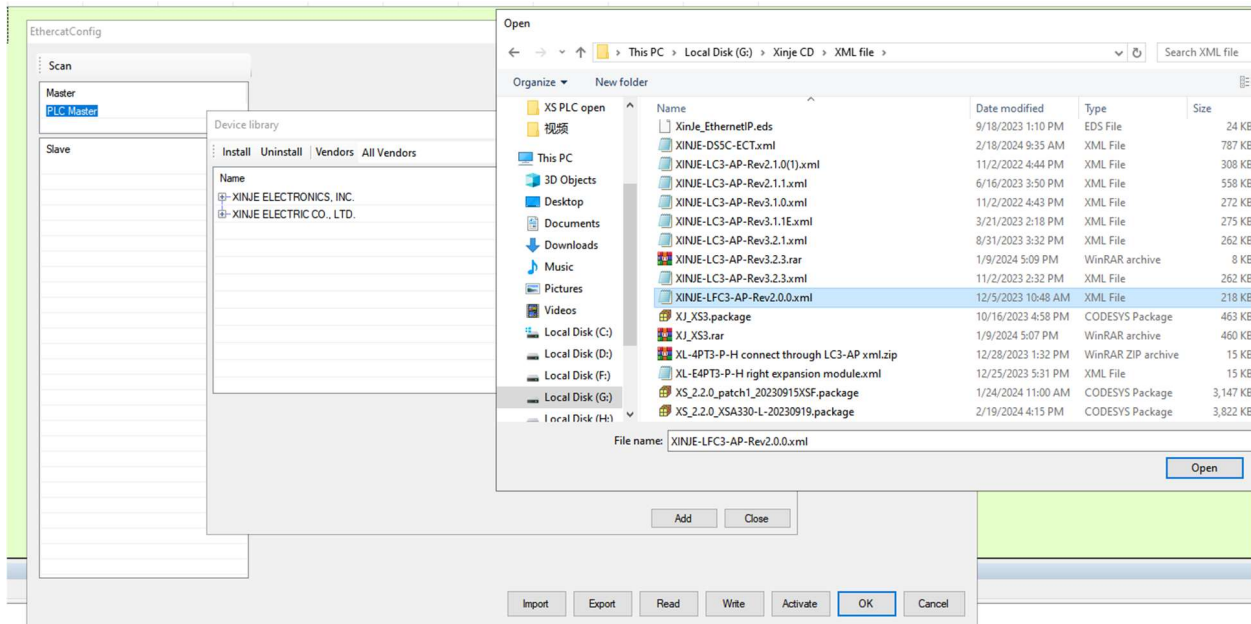

3. You can query the added xml files in the device library.

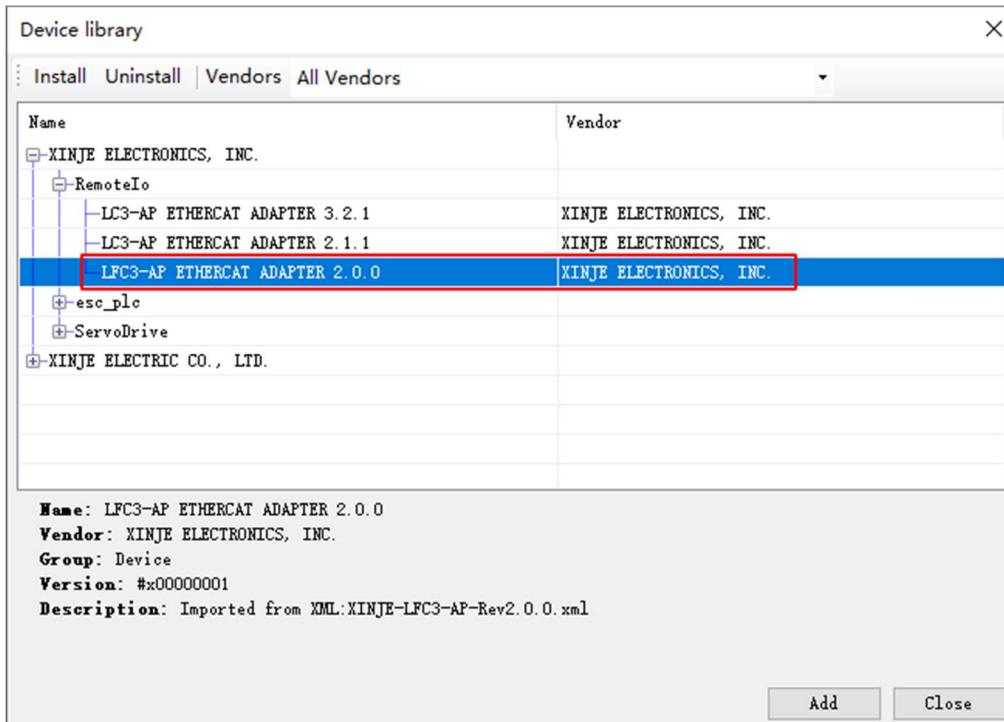

4. Check the connection between PLC and LFC3-AP, which follows the principle of "bottom in and top out".

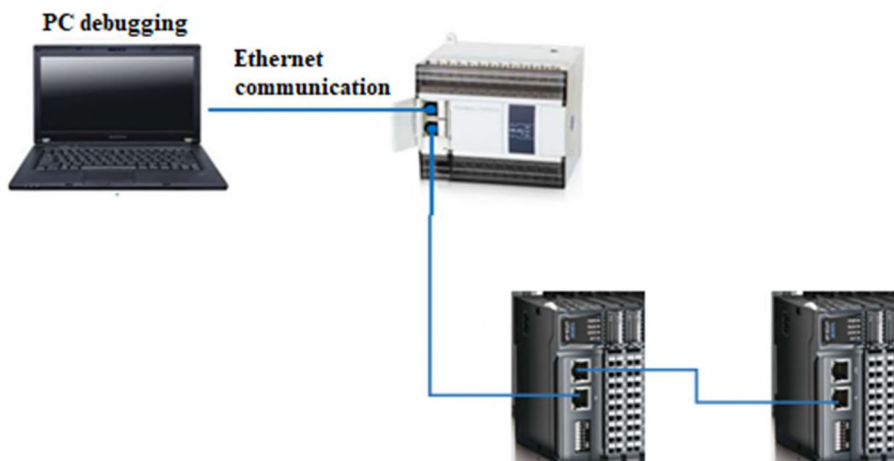

5. Connect the PLC using XDPPro, click "Scan" in "EthercatMaster", and the PLC will automatically add the following slave stations and modules.

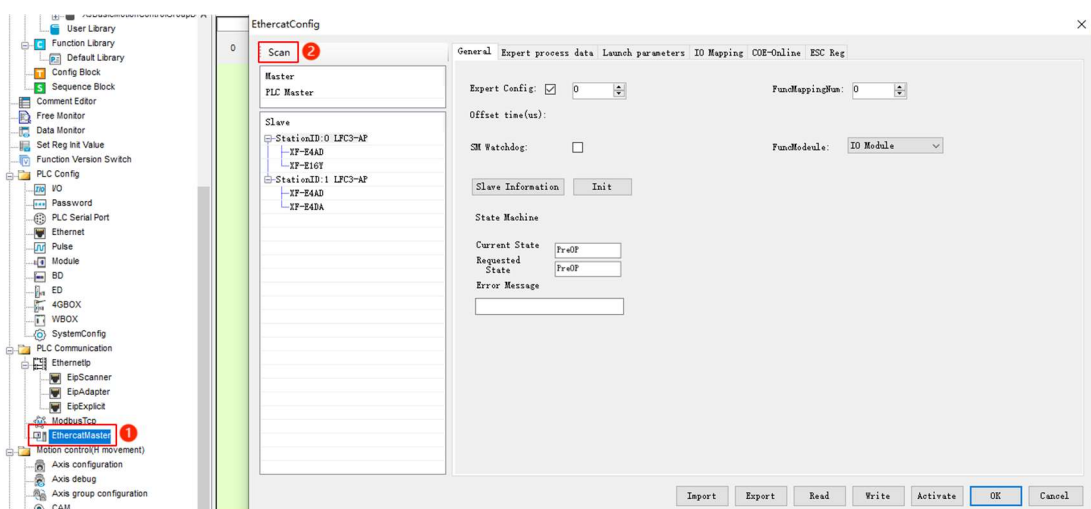

- Click "Configuration Write", after successful writing, click "Activate" to activate the slave station. You can check whether the slave station is in "OP" status in the "Status Machine".

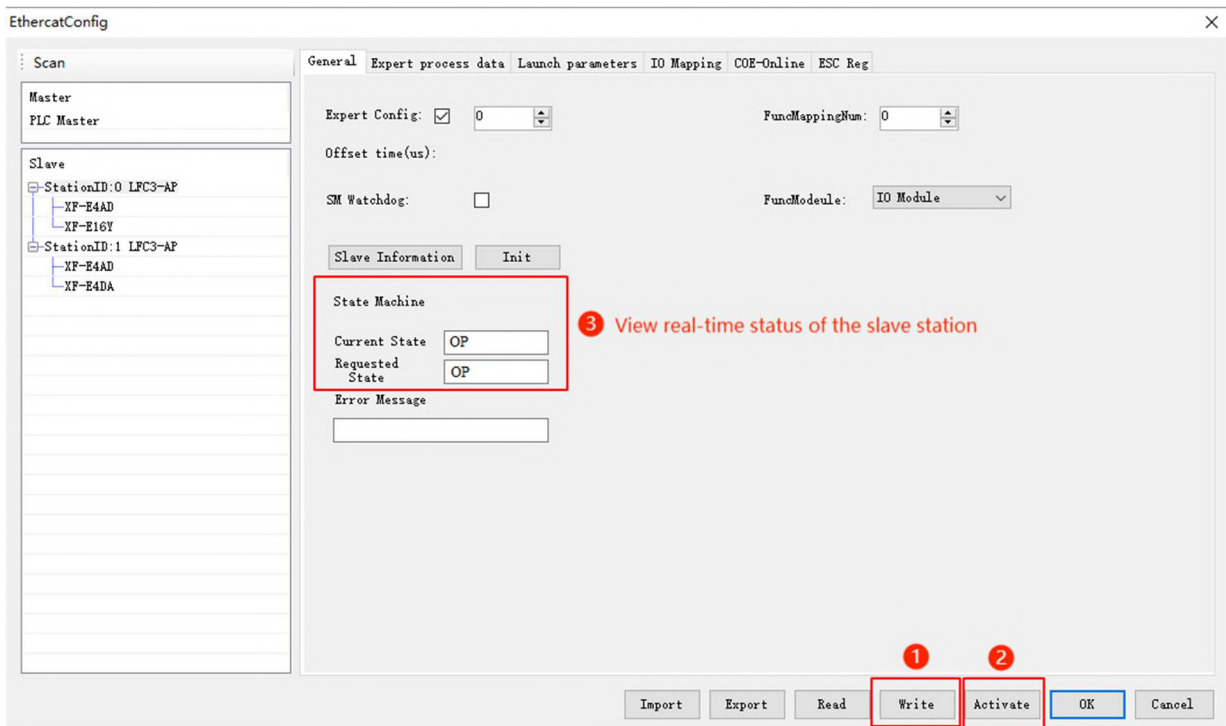

- In the IO mapping of the module, the mapping address can be viewed, and the corresponding output points can be controlled in the IO mapping to check whether the actual output of the module is consistent with the IO mapping control.

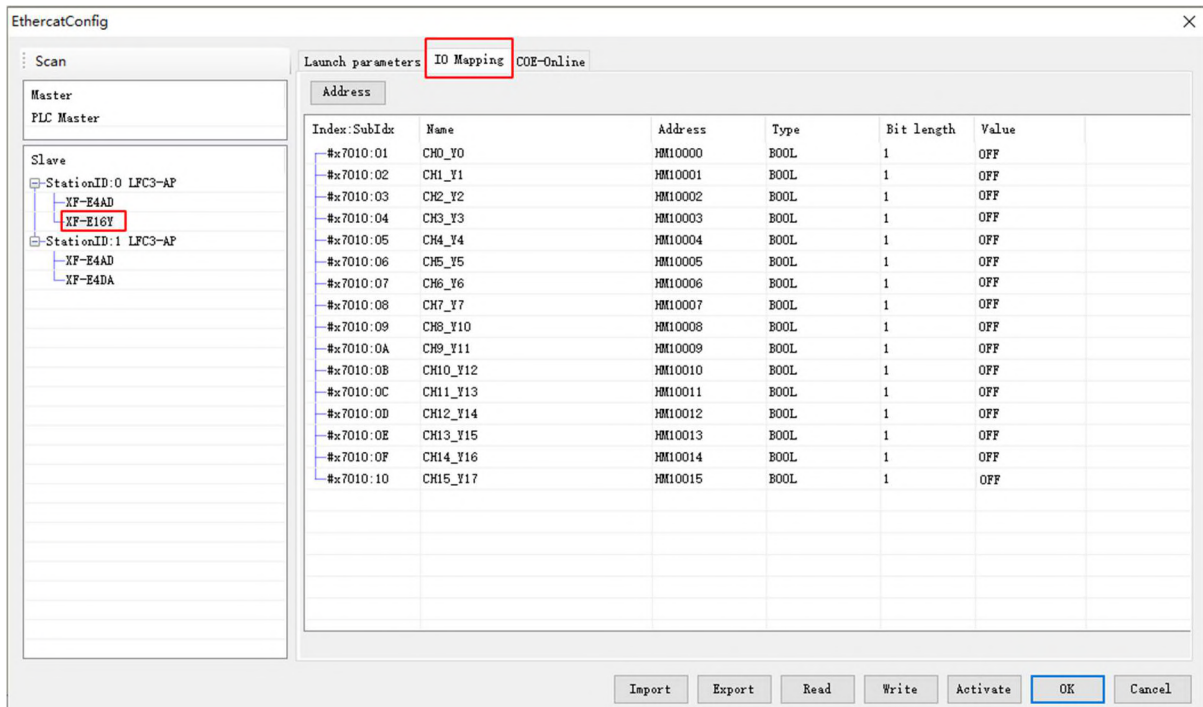

3.2.6.2 LFC3-AP and Codesys connection

1. Add the ".xml" file corresponding to LFC3-AP. Open the XS Studio programming software, click on "Device repository..." in the "Tools" dropdown menu, and add the corresponding ".xml" file.

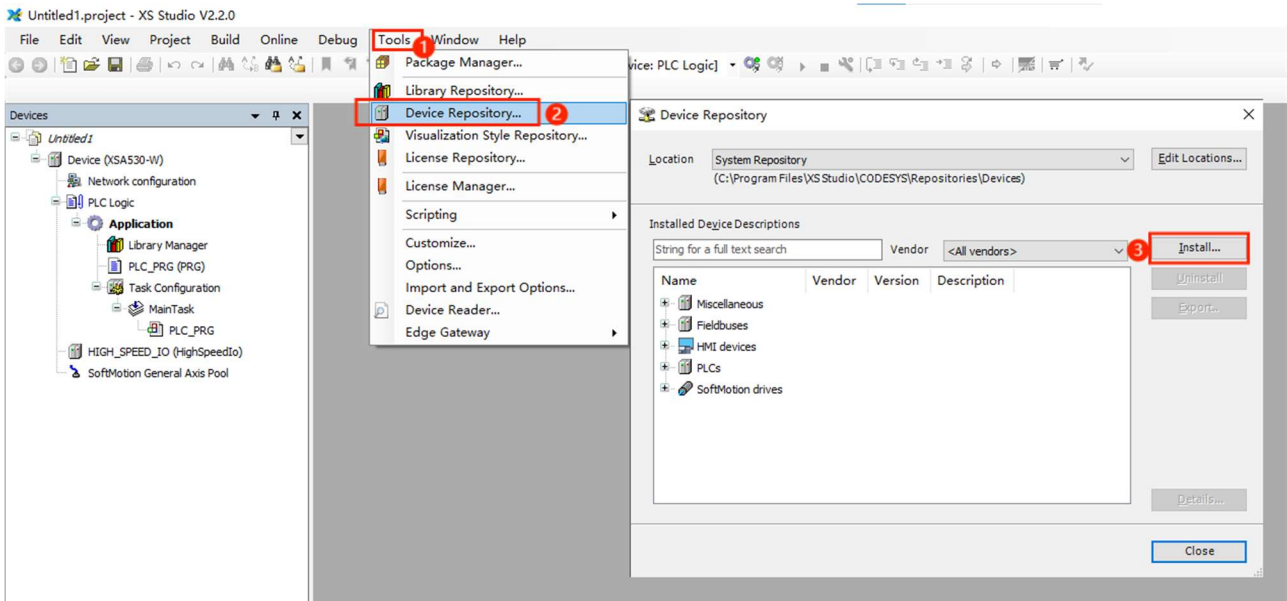

2. Click on "Network Configuration" to select "EtherCAT Master Station" and complete the configuration of the EtherCAT protocol.

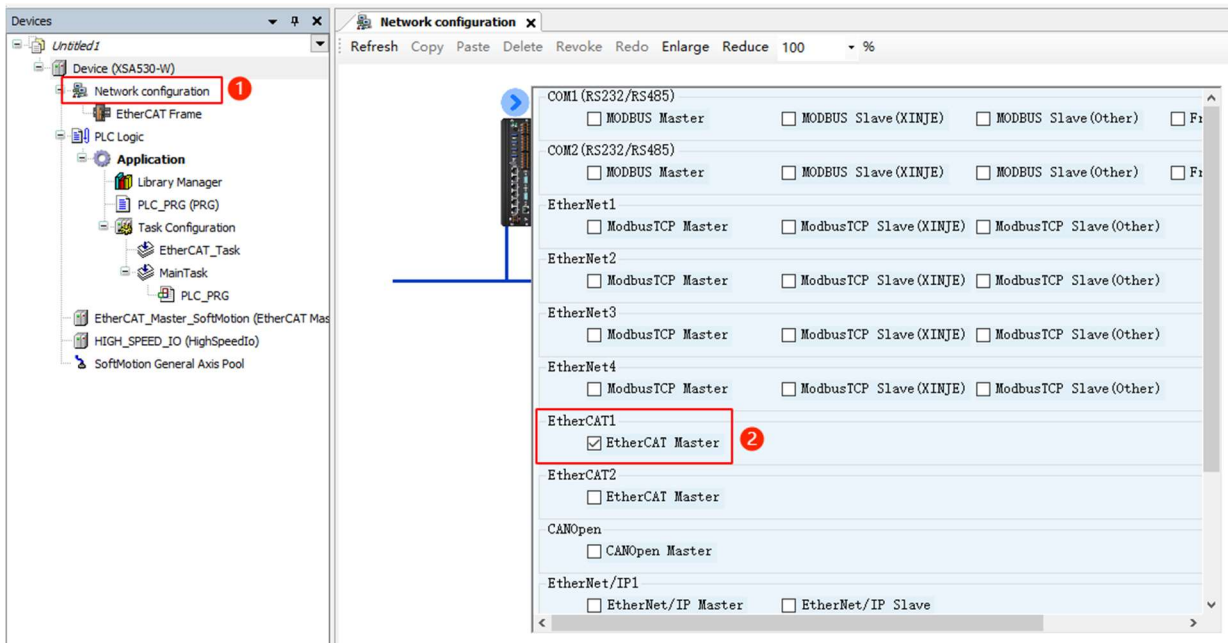

3. Double click on "EtherCAT_Master_SoftMotion" to select and configure the Ethercat source address (MAC).

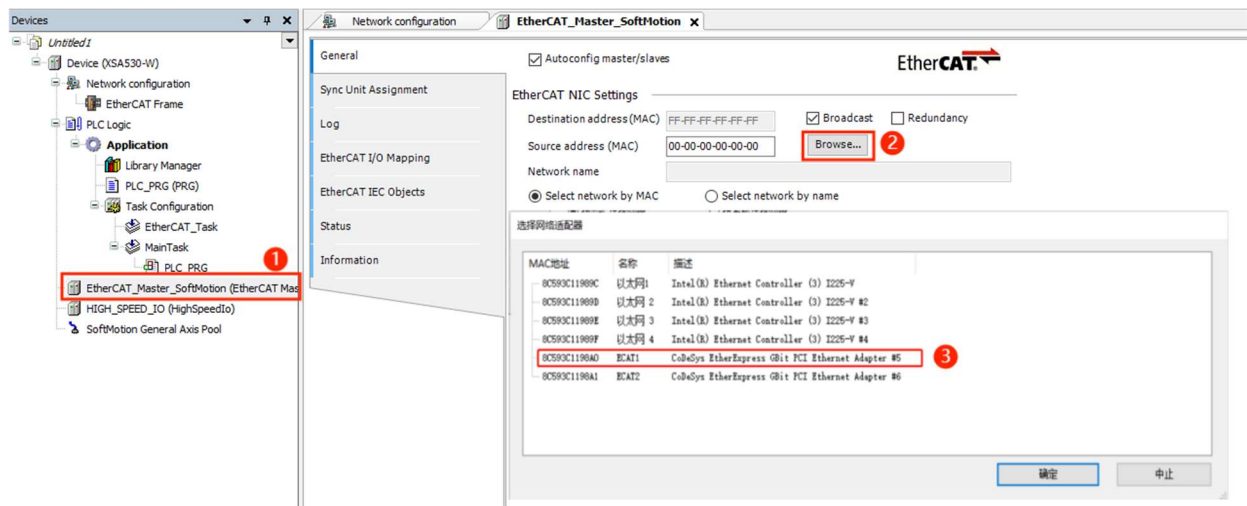

4. Right click on "EtherCAT_Master_SoftMotion" and click on the scanning device to scan and configure the information of the LFC3-AP+XF-E16YT+XF-E4AD module.

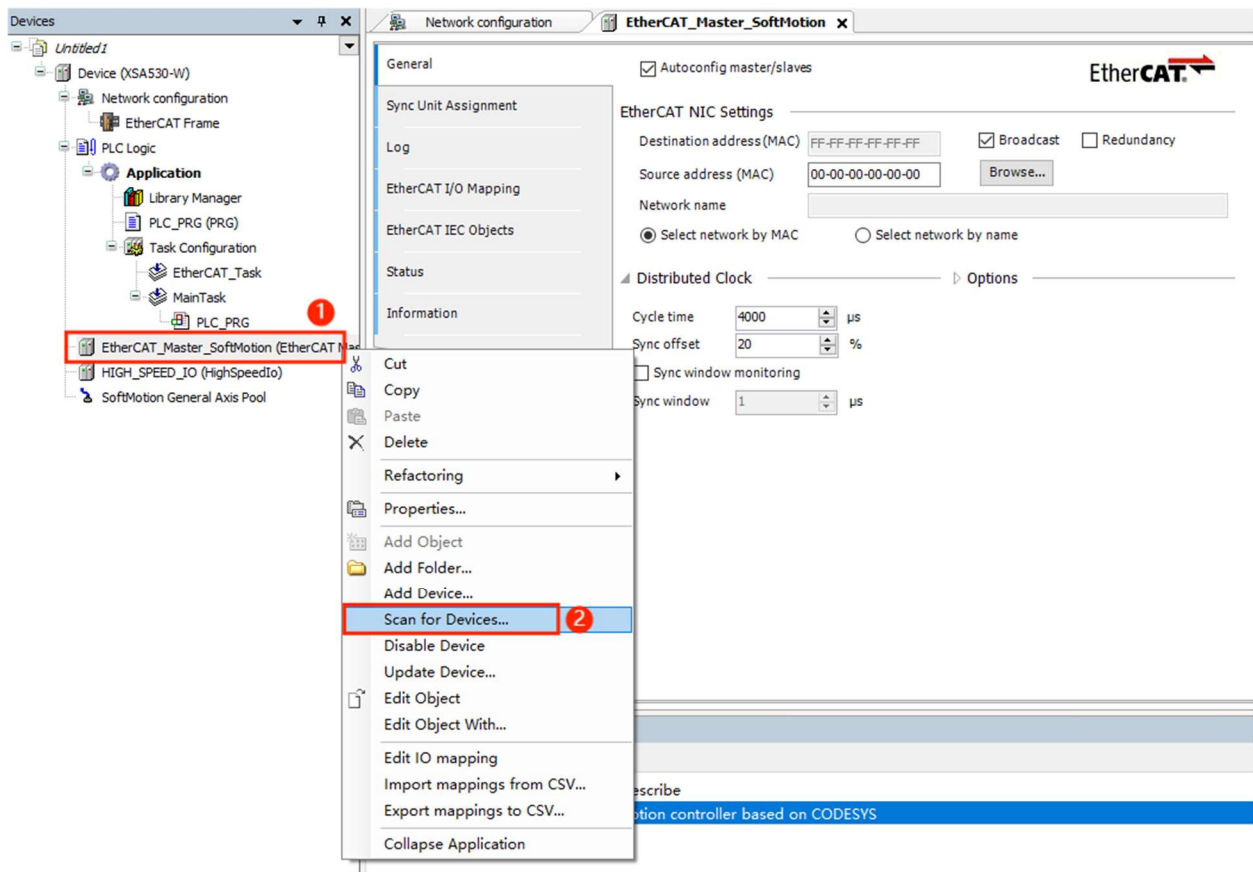

5. After completing the scan, click "Copy all devices to the project" and view the remote IO configuration status scanned under the left tree.

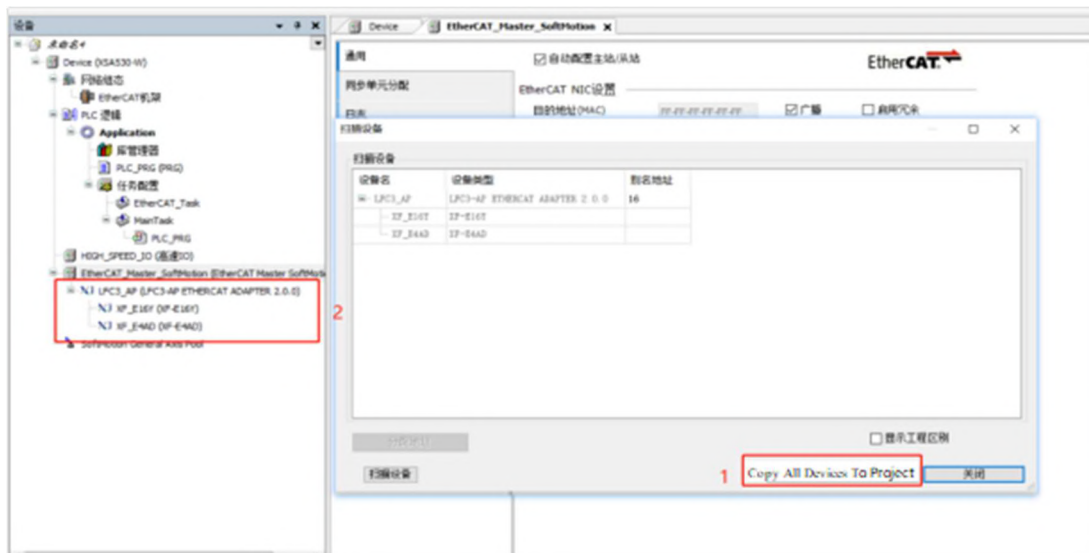

- Click to log in and download the corresponding configuration information to the PLC, and view the current running results.

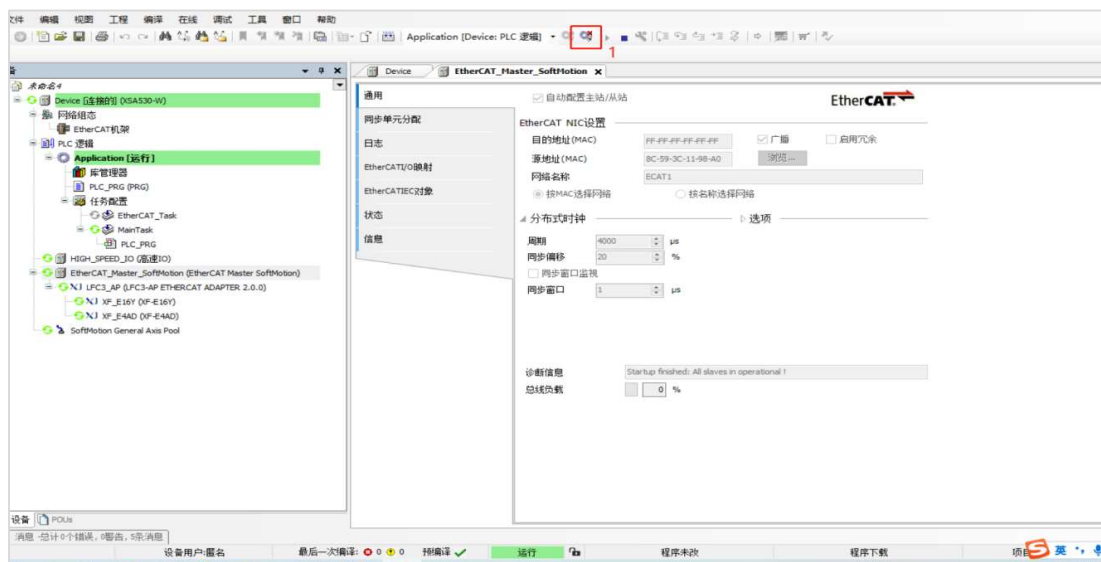

- Click on the corresponding module in the left tree, and under the corresponding module, click on "Module I/O Mapping" to monitor or control the corresponding points, and check that the corresponding monitoring or control matches the required output.

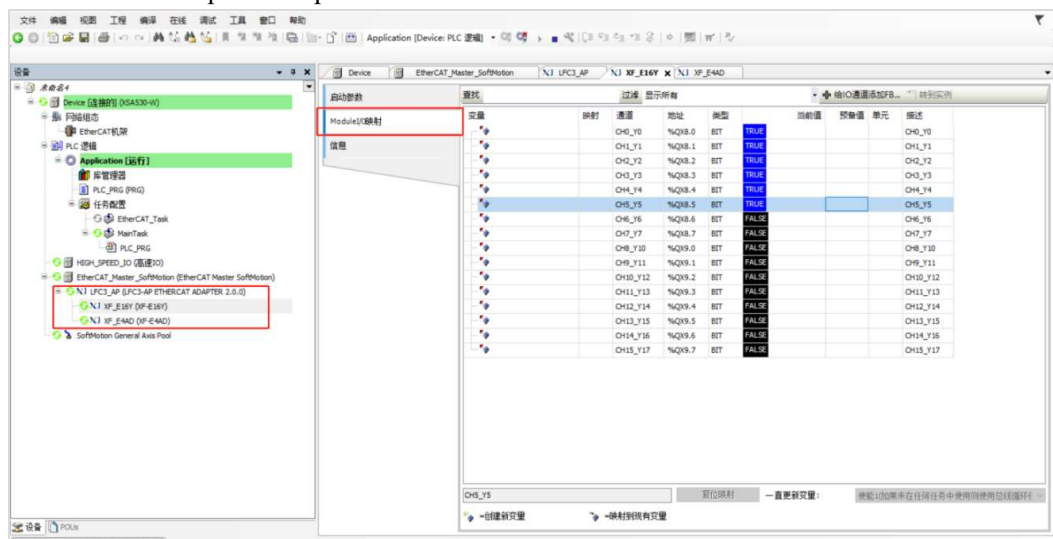

3.2.6.3 LFC3-AP connected to Omron

1. Click on "Controller", select "Communication Settings", and fill in the IP address of the PLC to be communicated in the specified remote IP address, click on "Ethernet Communication Test" and the display "Test Successful" indicates that the communication between the PC and PLC is successful, click "OK" to complete the communication configuration operation.

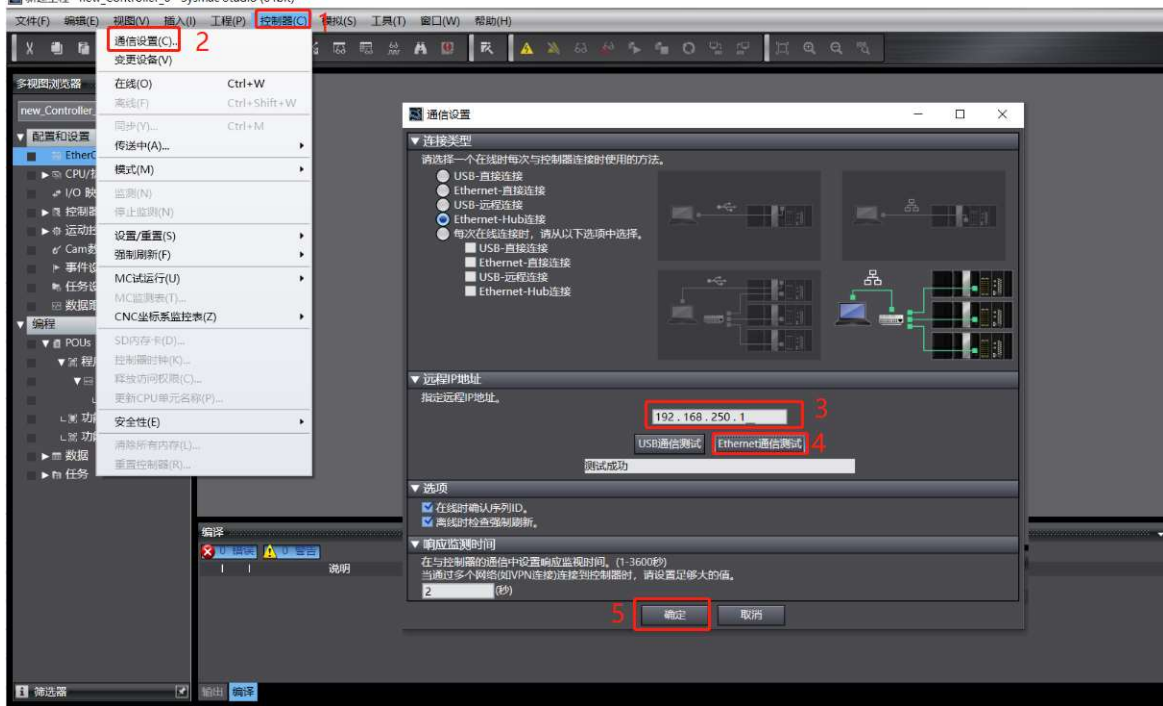

2. Add the ".xml" file corresponding to LFC3-AP. Open the Omron "Sysmac Studio" programming software, double-click "EtherCAT", right-click "Main Device", click "Display ESI Library" to install the corresponding ".xml" parsing file, click "Close" to complete the installation of the parsing file.

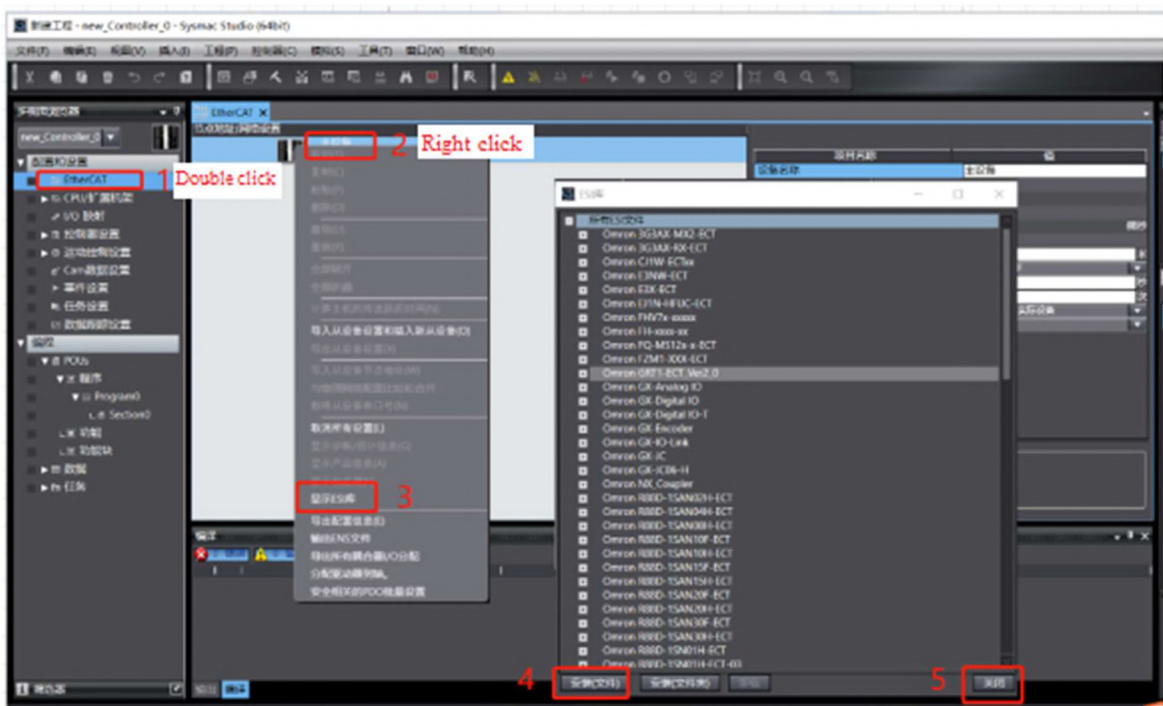

- Click "Online" to put the PLC in an online state, right-click on "Main Device" and select "Compare and Merge with Physical Network Configuration", configure LFC3-AP+XF-E16YT+XF-E4AD.

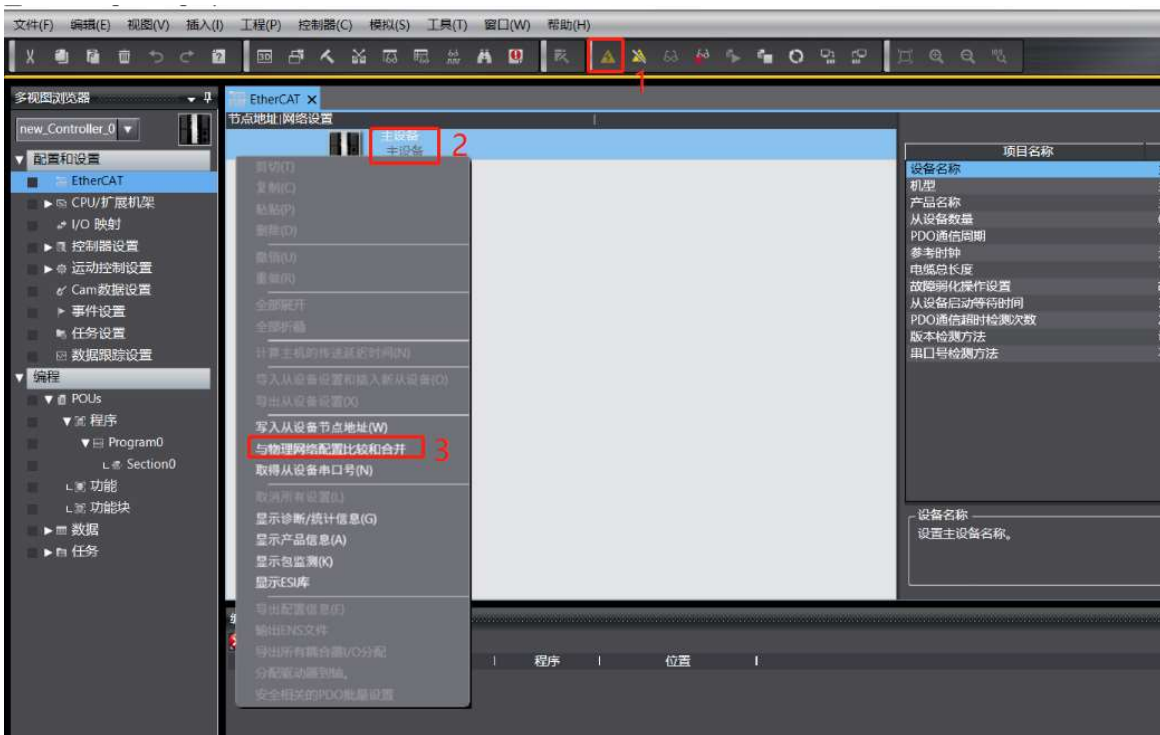

- On the comparison and merging page of the same physical network configuration, click "Apply Physical Network Configuration (A)" to synchronize the scanned node information of LFC3-AP to "Network Configuration on Node Address Sysmac Studio".

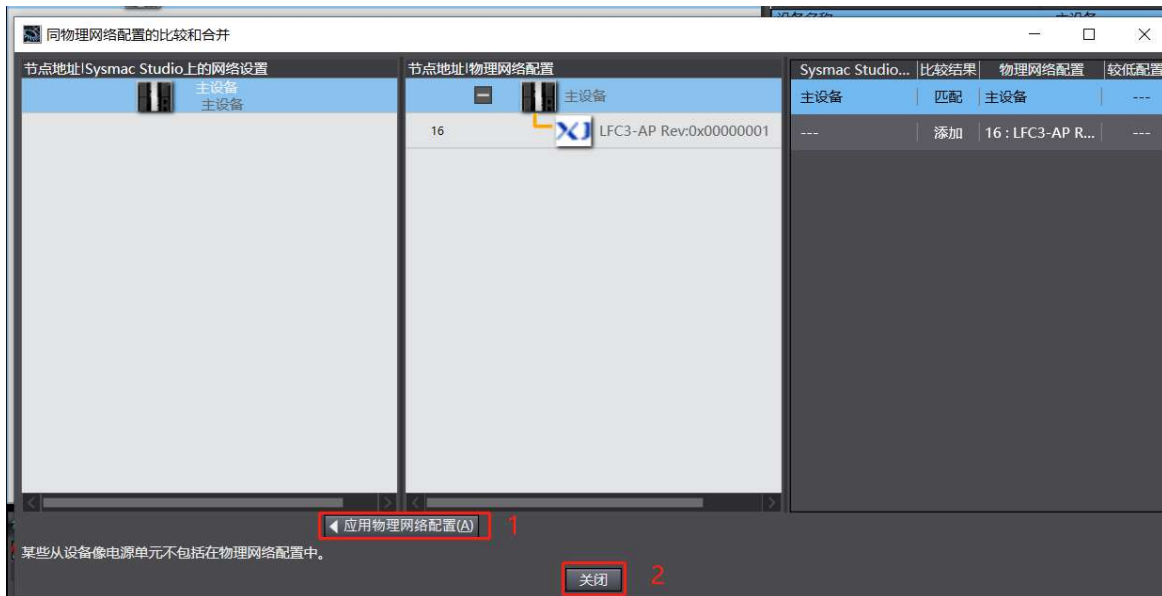

- Click "Sync" on the corresponding synchronization interface and click "Transfer to Controller".

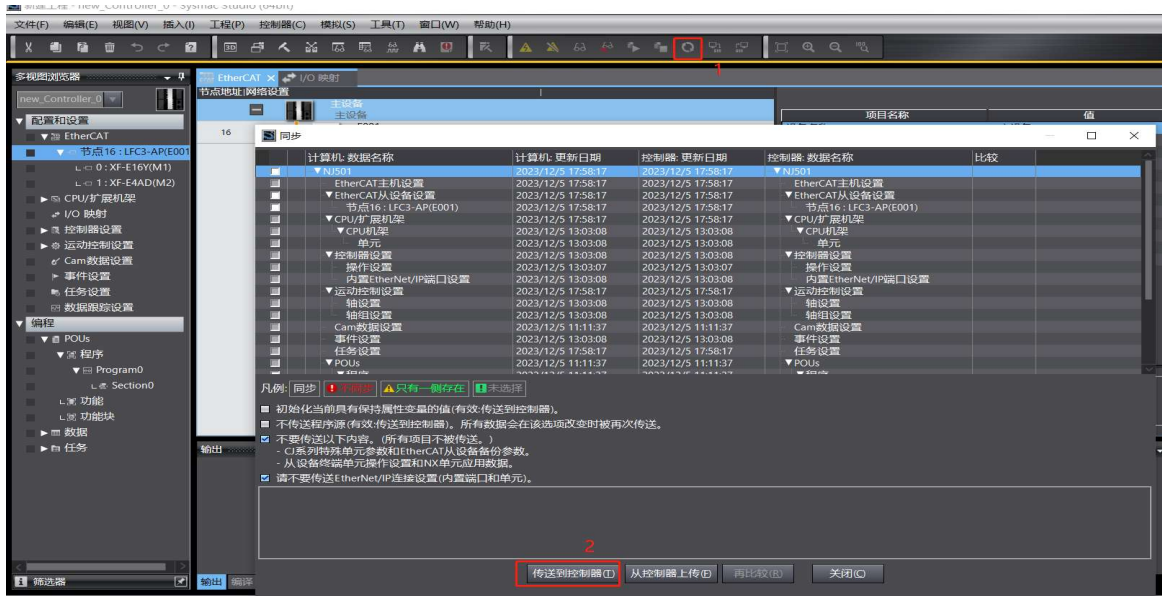

- View the corresponding node and module information under the left tree of Ethercat, and verify that the scanned module matches the actual configured module, click on "IO Mapping" to view or control the corresponding variables, the output viewing module corresponding to the setting has a corresponding output signal, and the external excitation signal corresponds to the viewing analog input value.

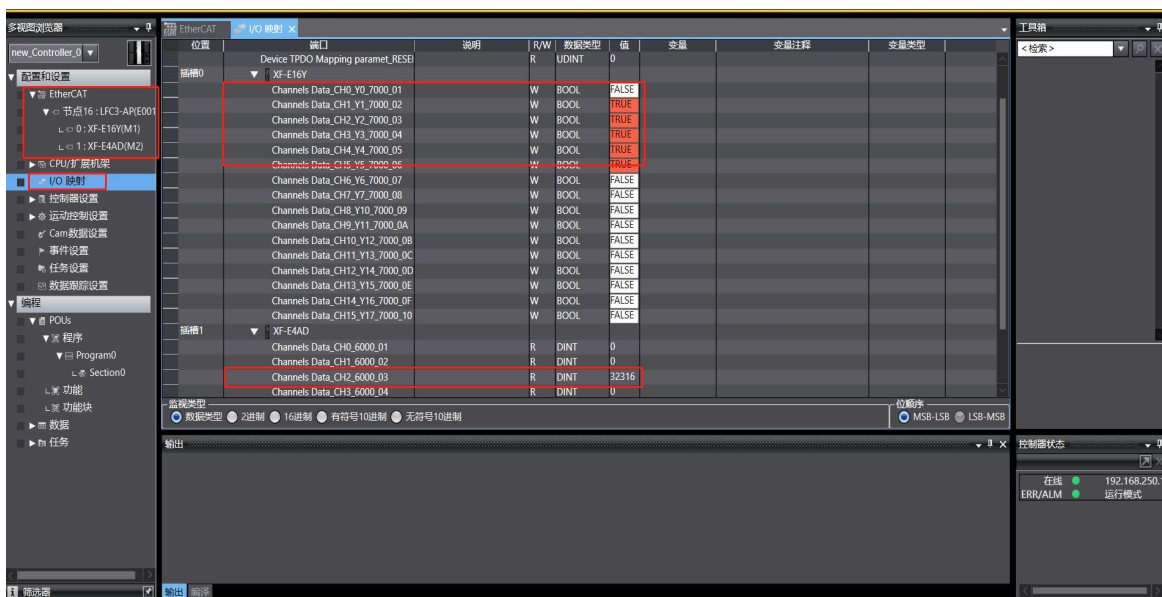

3.3 PROFINET coupler LFP3-AP

3.3.1 Overview

The LFP3-AP coupler unit supports the PROFINET bus communication protocol, and a single adapter module can connect up to 32 XF series I/O modules at most. Capable of connecting with Siemens 200smart, 1200, 1500 series PLCs, and seamlessly connecting with Botu software.

- Compact structure, saving installation space.
- Supports RT and IRT transmission modes.
- Support MRP and MRPD redundancy.
- Compatible with Siemens and TIA portal.
- Support firmware upgrade for network ports.
- Maximum support for 32 expansion modules.

■ Module version

Hardware version	Firmware version	Function
H2.0.0	V2.0.0	Basic functions for the first official production

3.3.2 Module view

1) Description of each section



No.	Name	No.	Name
①	DC24V power supply terminal	②	Status indicator
③	EtherNet	④	MAC address
⑤	Guide rail buckle		

2) System indicator

Abbreviation	Explanation
PWR	Power indicator light, lit when the power system is normal
RUN	Running indicator light, lit up when the system is running normally
ERR	System malfunction indicator light, lit up when system malfunction occurs
SF	Module error indicator light

● RUN indicator

RUN indicator	State	Explanation
Light	Operating mode	Establish communication with the main station
Extinguish	Not running	Not connected
Single flicker* ¹	Find	TIA Portal clicks on the "flashing LED" function
Flash* ²	Firmware update	Firmware update in progress
Light	Operating mode	Establish communication with the main station

● ERR indicator

ERR indicator	Explanation	Processing method
Extinguish	No Error	Normal operation
Light	PDI watchdog timeout	<ol style="list-style-type: none"> 1. Unplugged network cable 2. Diagnostic message sent 3. The number of configured modules is consistent with the number of physical connections, but the modules physically connected to a certain slot are not consistent with the actual configuration (at this time, the SF light will also remain on) 4. The number of configured modules exceeds the actual number of physical connections

● SF indicator

SF indicator	Explanation	Processing method
Extinguish	Expansion module is normal	
Single flicker* ⁴	Expansion module failure	<ol style="list-style-type: none"> 1. Check the module power supply. 2. Check if the module is faulty. Replace the module. 3. Check the external channel wiring status.
Light	Detect configuration topology mismatch with reality	<ol style="list-style-type: none"> 1. Check the communication interface contact of the expansion module or restart the entire system. 2. Check if the module in the corresponding slot is powered off or unplugged. 3. Check the communication interface contact of the expansion module or restart the entire system.

- *1: Single flash as shown in the figure below:

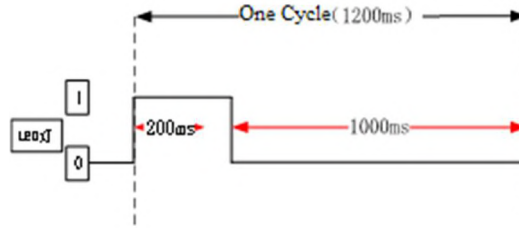

- *2: Double flashing as shown in the figure below:

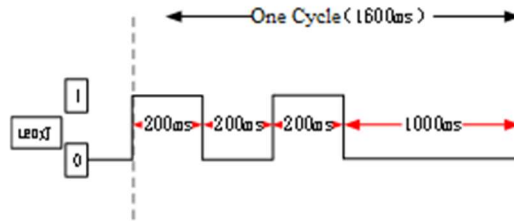

3.3.3 General specification

General specification		
Project		Specifications
Operating temperature	Maximum temperature	55°C
	Minimum temperature	-20°C
Transportation/Storage Temperature	Maximum temperature	70°C
	Minimum temperature	-40°C
Environmental humidity (including operation/storage)	Upper limit	95%
	Lower limit	10%
IP code		IP20
Anti vibration		Compliant with IEC61131-2 Under intermittent vibration (frequency 5-9Hz, constant amplitude 3.5mm peak displacement) and (frequency 9-150Hz, constant acceleration 1.0g peak acceleration) Under continuous intermittent vibration (frequency 5-9Hz half amplitude 1.75mm displacement) and (frequency 9-150Hz constant acceleration 0.5g constant frame amplitude) Scan 10 times in X, Y, and Z directions
Impact resistance		Complies with IEC61131-2 standard The impact strength is 15G (peak) and the duration is 11ms. It is applied to three mutually perpendicular axes, and each axis is impacted 3 times (a total of 18 impacts)
Using environment		Non corrosive gas
Using altitude		0-2000 m
Overvoltage level		II: Compliant with IEC61131-2

General specification	
Project	Specifications
Pollution level	2: Compliant with IEC61131-2
Anti interference EMC	Compliant with IEC 61131-2 IEC61000-6-4 Type B
Related certifications	CE

3.3.4 Technical specifications

Project	Specifications
Bus type	PROFINET
Rated input voltage	DC24V
Voltage allowable range	DC21.6-26.4V
Input current	120mA DC2V
Allow instant power outage time	10ms DC24V
Impulse current	10A DC26.4V
Power protection	Anti reverse connection protection, overcurrent protection, surge absorption
Single AP process data	Input maximum 1440 bytes, output maximum 1440 bytes
Communication mode	RT mode, IRT mode
Media redundancy (MRP)	Support
Media Path Planning Redundancy (MRPD)	Support
Network interface	2 RJ45 ports
Connection rate	10/100Mbps adaptive, full duplex
Transmission distance	Less than or equal to 100m between two nodes
Transmission medium	Over five categories and above
Topological structure	Supports line type, star type, tree type, etc
Number of expansion modules	Supports 32 modules
Firmware upgrade	Support

3.3.5 Installation&Wiring

3.3.5.1 Appearance dimension diagram

(Unit: mm)

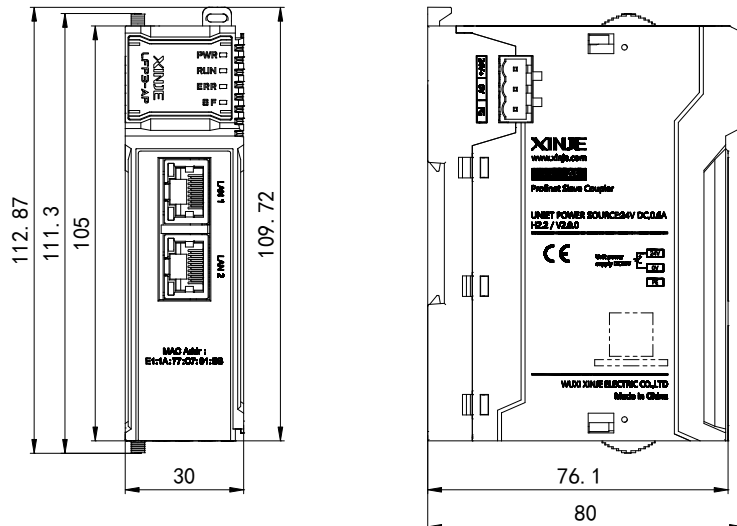

3.3.5.2 Installation method

The module is installed using DIN rails, which must comply with the IEC 60715 standard (35mm wide, 1mm thick). The size information is shown in the following figure, in millimeters.

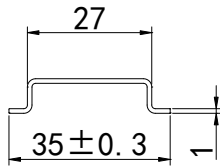

Note

When the module is installed on a non recommended DIN rail, the DIN rail latch may not lock properly.

3.3.5.3 Installation environment

This product can be installed in four positions (i.e. installation direction): horizontal, vertical, top of cabinet, and bottom of cabinet, it is recommended to install in a horizontal direction, and the heat dissipation design should be through natural convection, to ensure normal ventilation and heat dissipation, and to reserve sufficient wiring space, the minimum gap must be left around this product, as shown in the following figure :

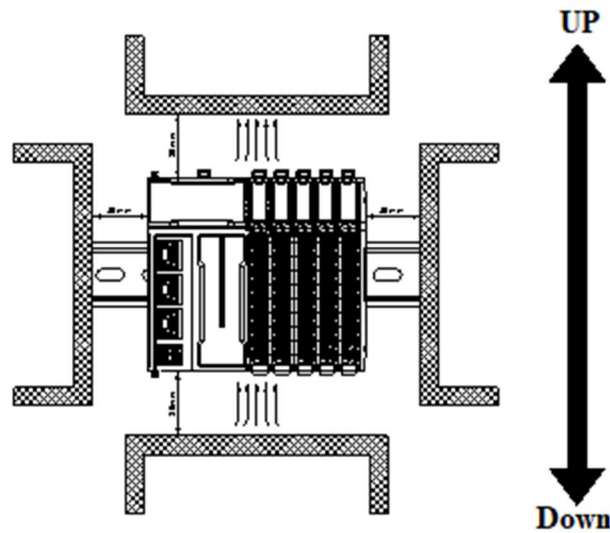

If there is a high-temperature heat source equipment (heater, transformer, high resistance, etc.) around this product, at least 100mm gap should be left between it and the high-temperature heat source equipment.

3.3.6 Use Cases

3.3.6.1 LFP3-AP connected to Siemens S7-1200/1500

1. Create a new project and select the corresponding PLC hardware.

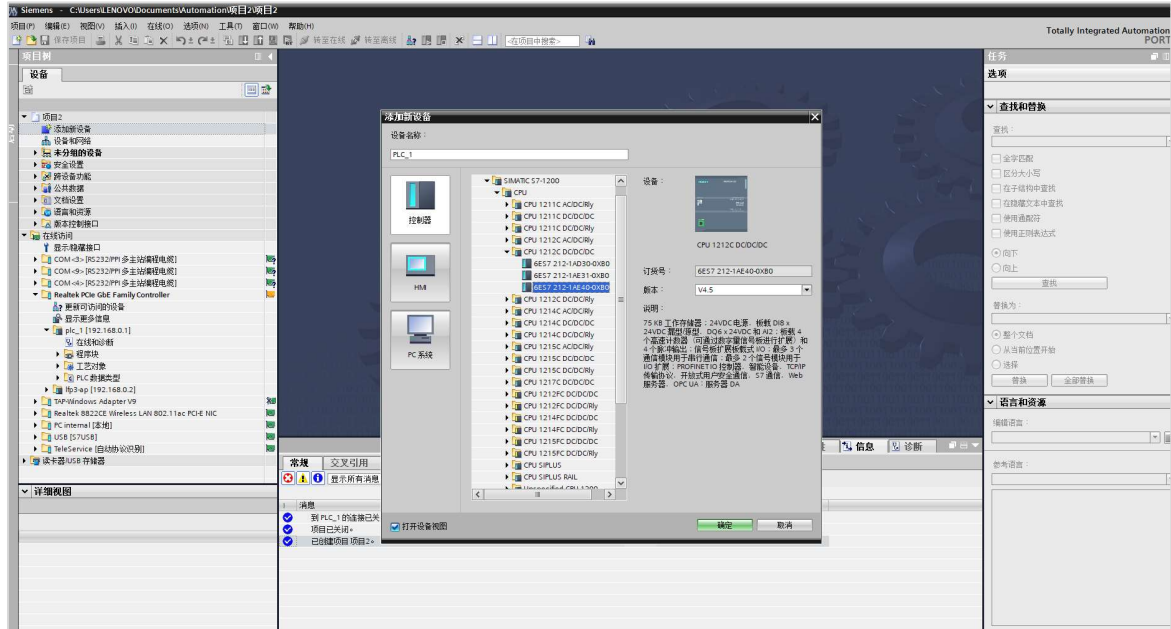

2. In the menu bar "Selection", click "Manage General Station Description Files (GSD)" to add the GSD file for LFP3-AP.

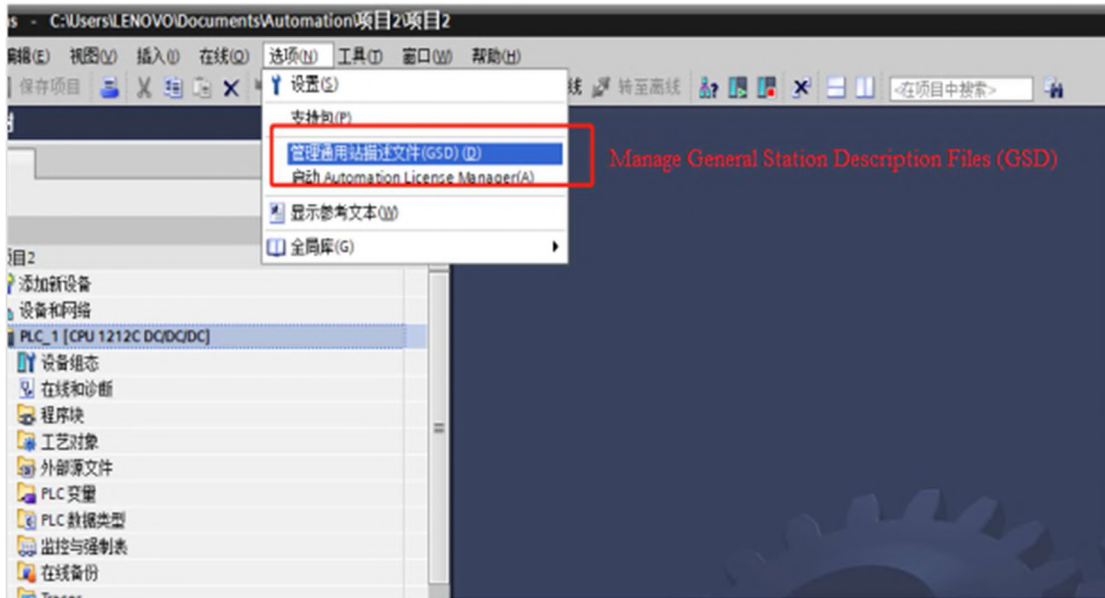

3. Select the folder where the GSD file is located in the source path, select the corresponding GSD file, and click "Install".

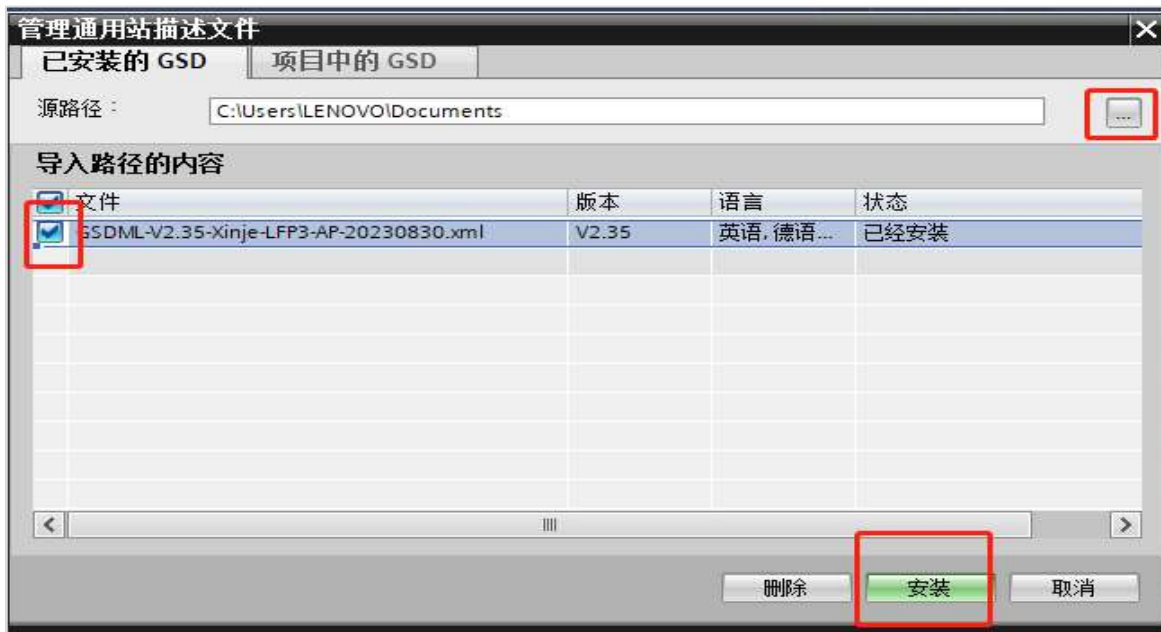

4. In the menu bar "Online", click "Hardware Detection" and then click "PROFINET Devices in the Network".

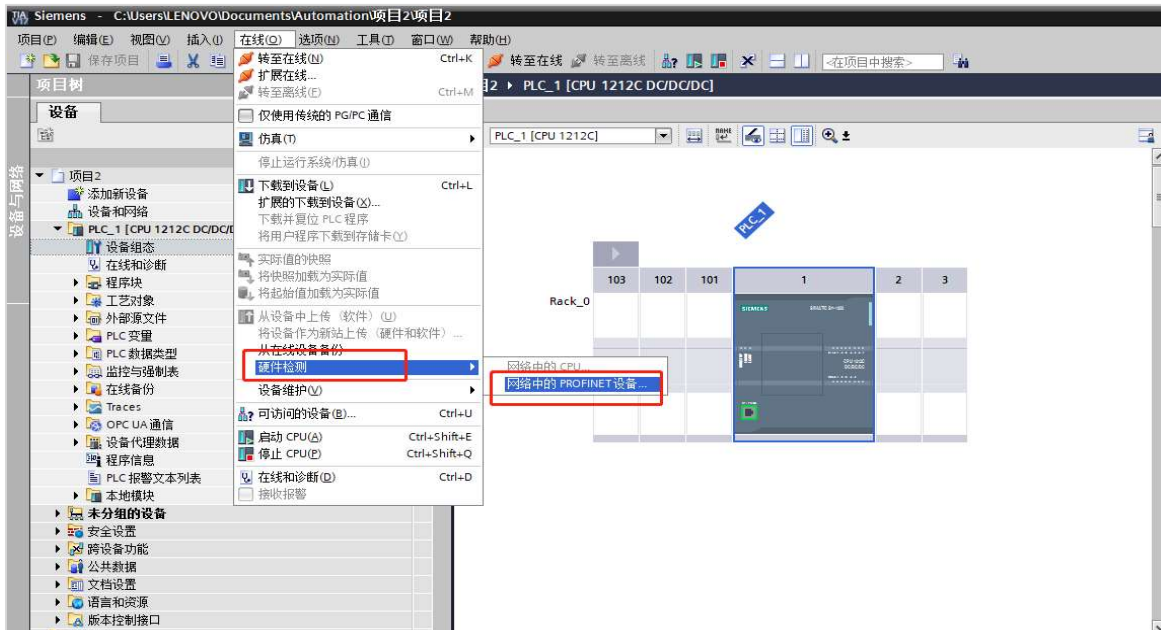

- Click "Start Search", select the "LFP3-AP" found in the search, and click "Add Device".

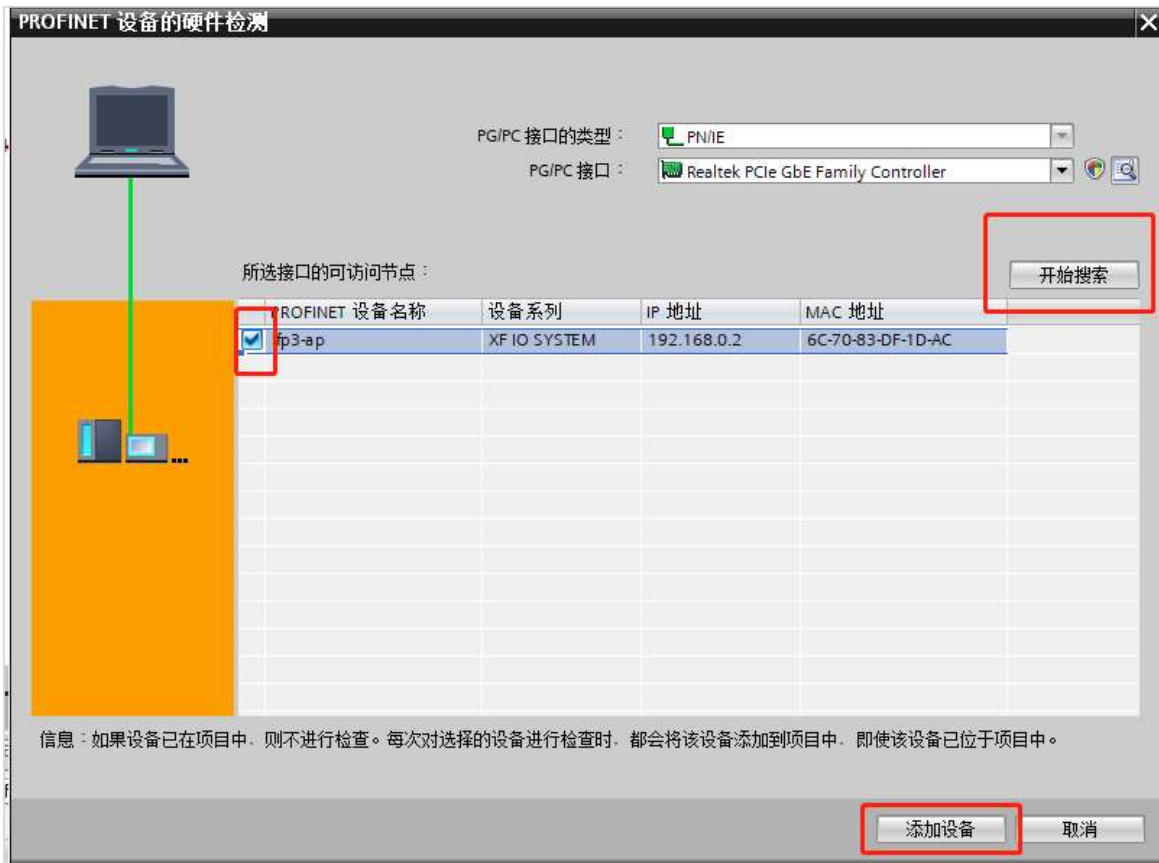

- In "Device Configuration", click "Network View" to view the newly added slave devices.

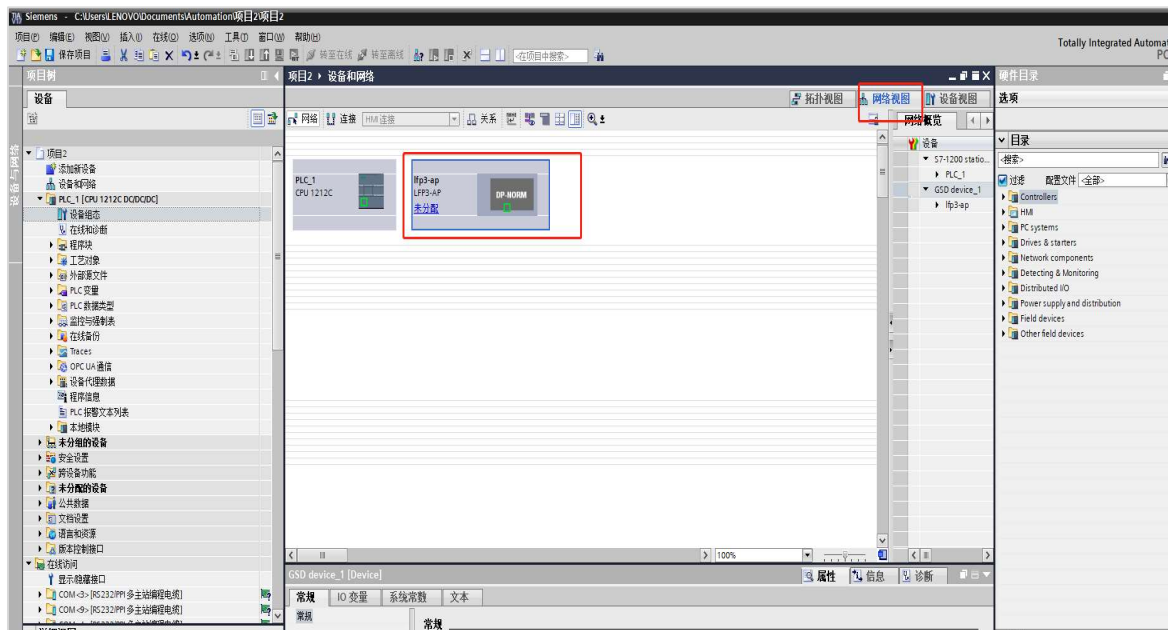

9. Click "Update List" to "Assign Names" to the corresponding slave stations.

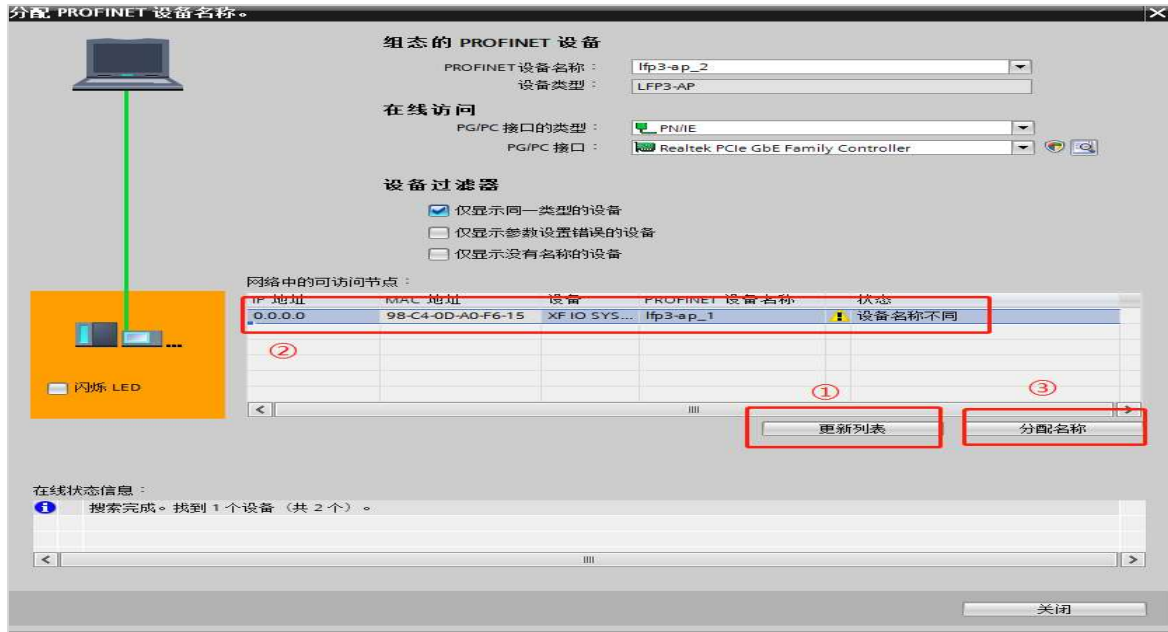

10. Click on LFP3-AP to enter the device view, where you can view the mapping addresses corresponding to the expansion module. For example, the input address of XF-E16X corresponds to I2.0-3.7, and the output address of XF-E16YT corresponds to Q2.0-3.7.

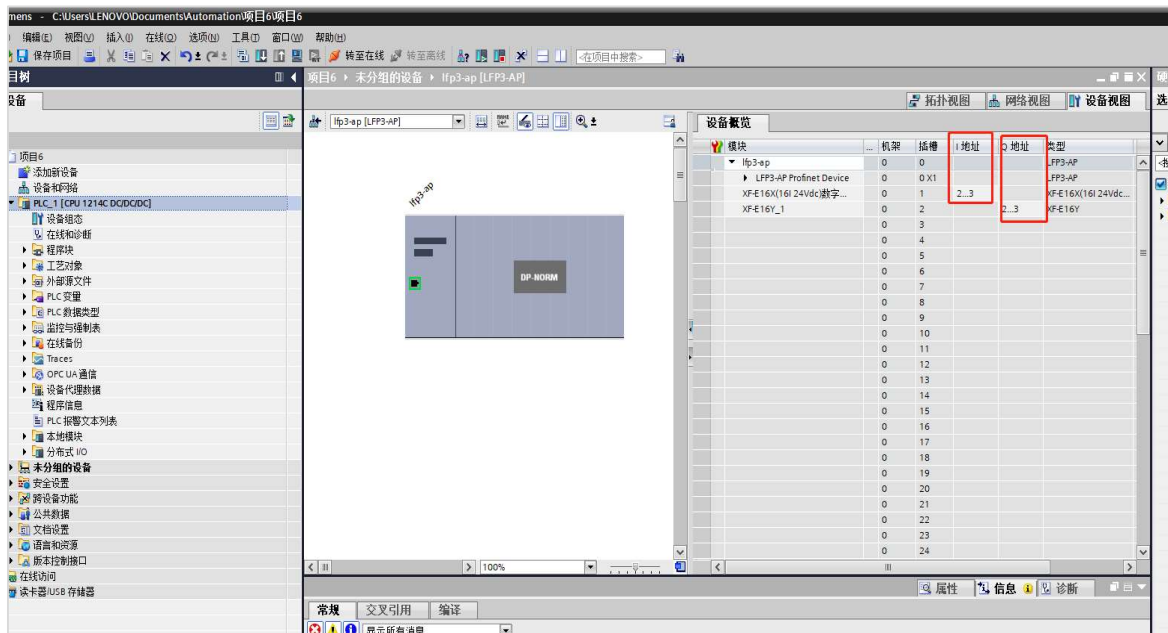

11. After setting up, click on compile and download the PLC program.

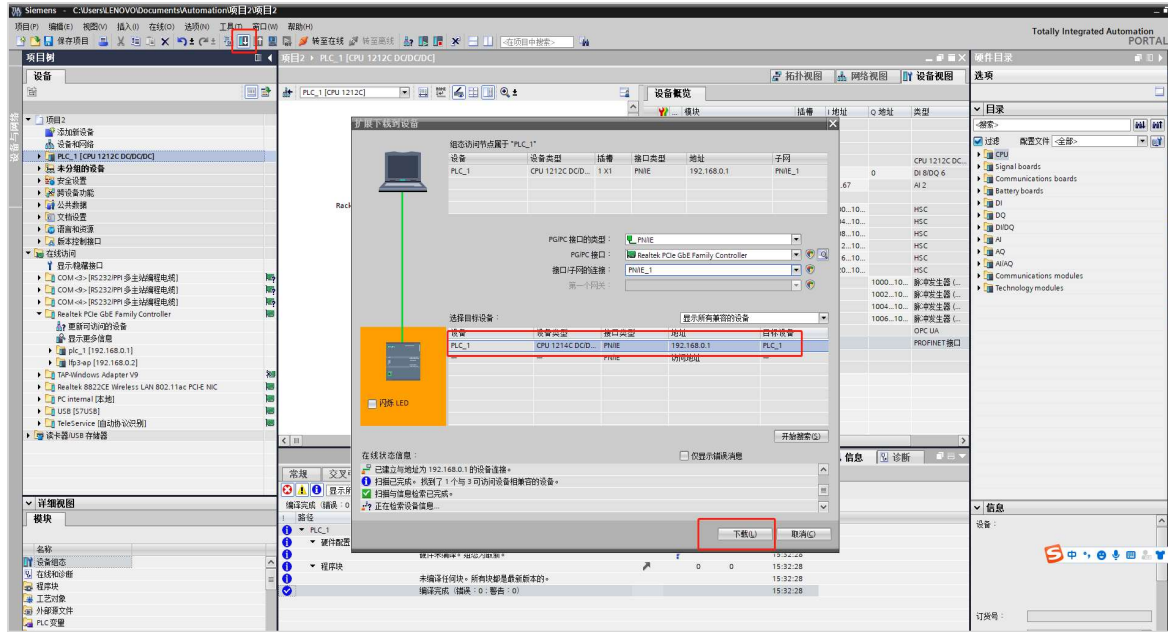

12. Click "Go Online" to check if the connection status of the module is normal.

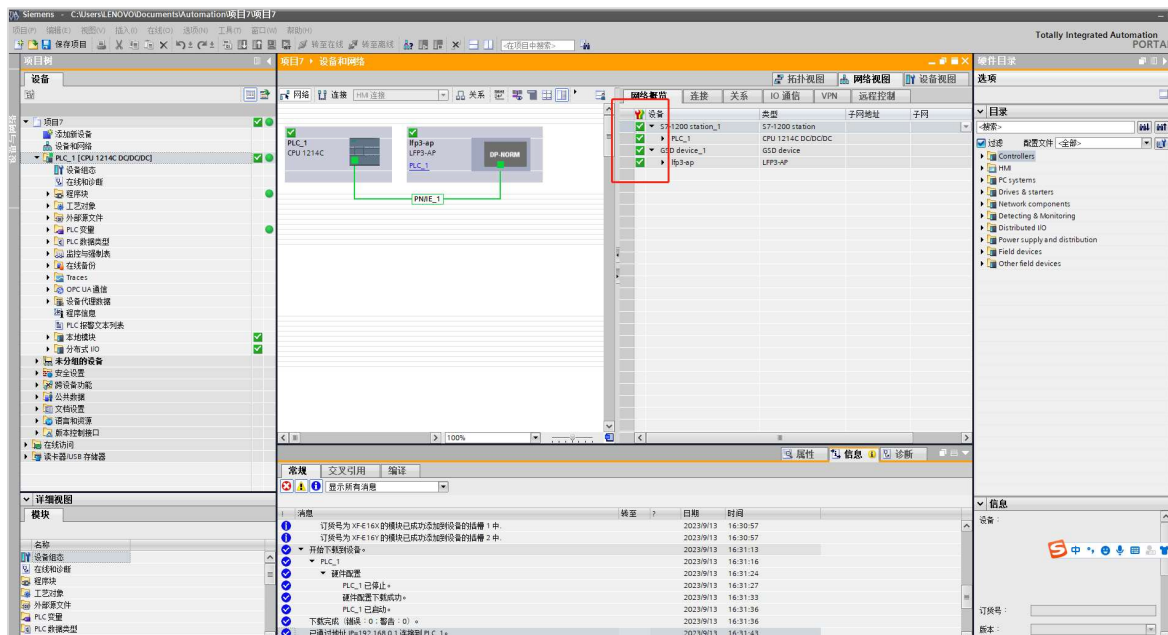

13. In the "Monitoring and Enforcement Table", a monitoring table can be added, mapped IO addresses can be added, and the input and output status of the expansion module can be monitored in real time.

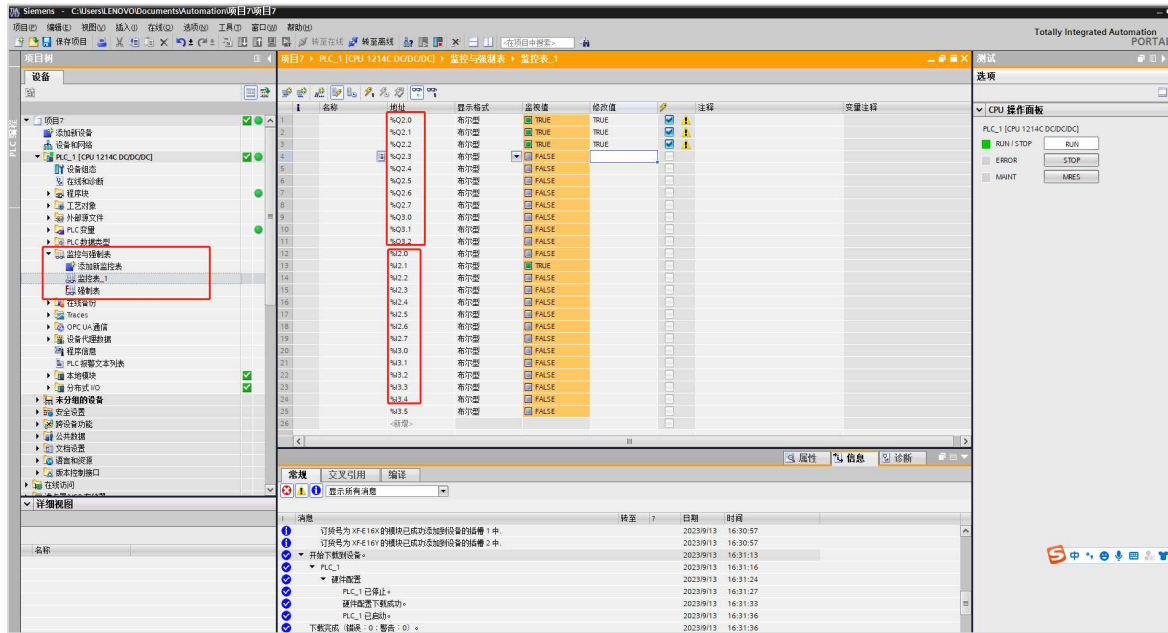

3.3.6.2 LFP3-AP connected to Siemens S7-200SMART

1. Require 200SMART firmware version V2.05 and above.
2. Power on the module and S7-200SMART, and connect the network port to the PC. Open the Siemens STEP 7-MicroWIN SMART software. Under the "File" menu, click on "GSDML Management". In the pop-up window, click browse to find the GSD file for LFP3-AP and click open to complete the installation of the GSD file.

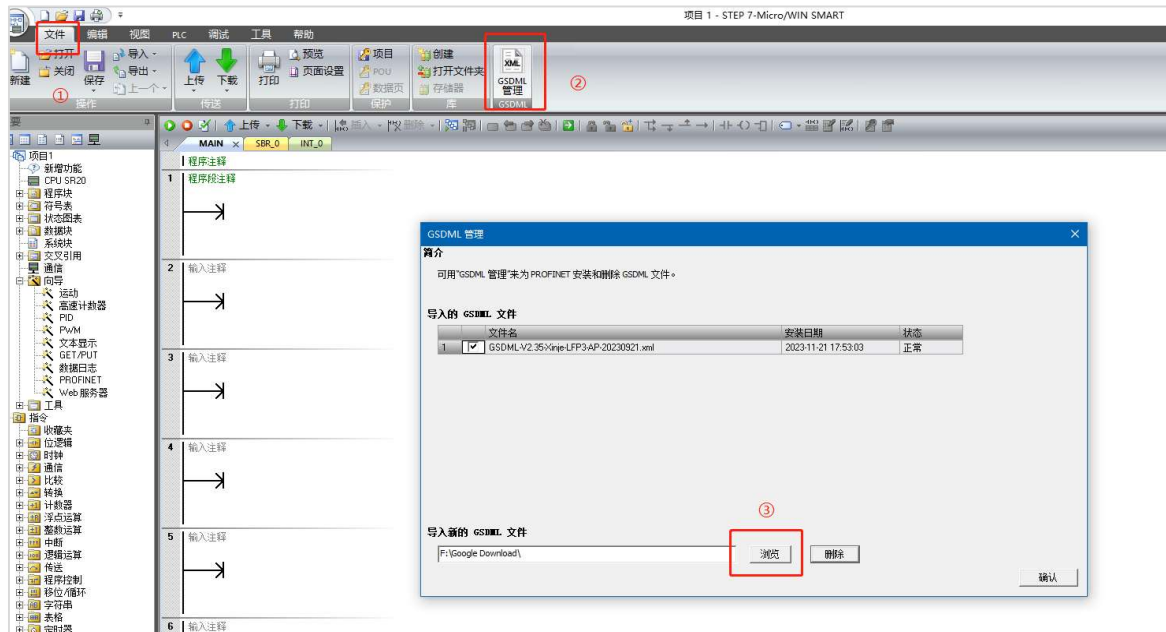

3. Click on the tool, click find PROFINET device, click find device, find LFC3-AP module, the module device name is lfp3-ap, you can click "EDIT" to customize the name. (Discovered device name, **it needs to be consistent with this name during configuration**)

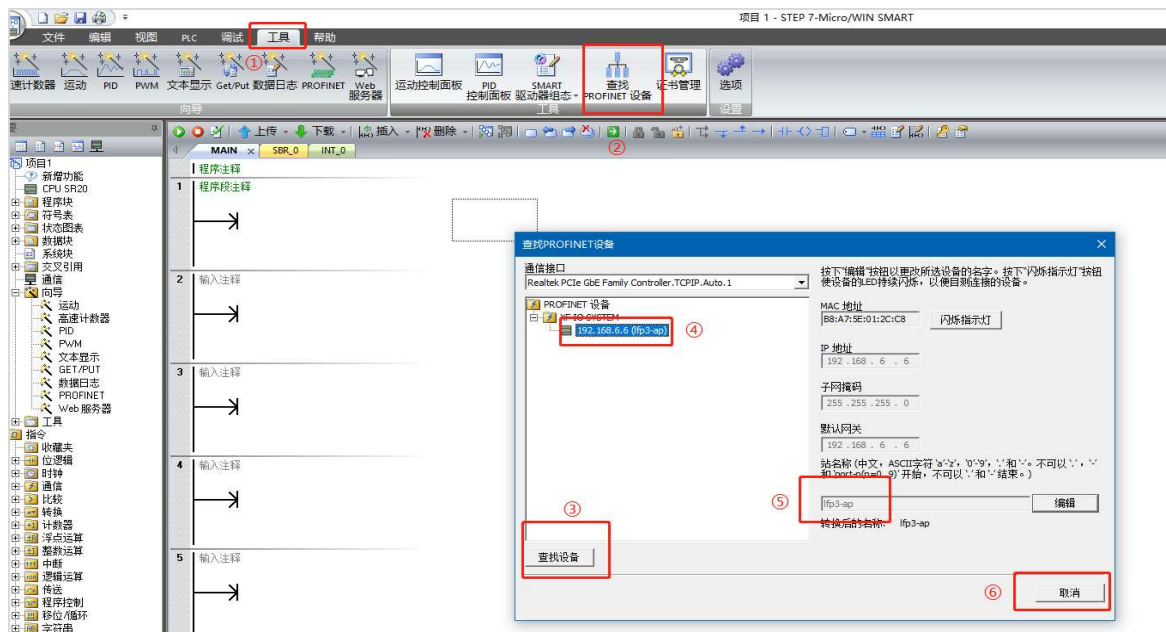

- Click on the tool and then click on PROFINET. Select the controller and modify the IP address of the PLC. Click "Next".

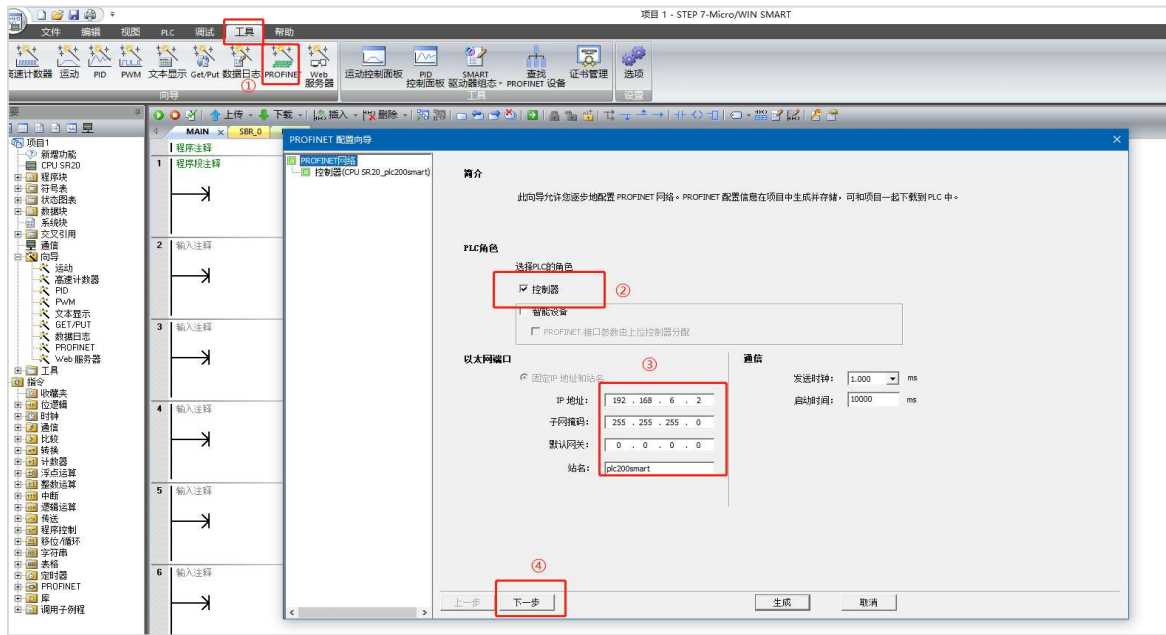

- Find LFP3-AP in the hardware directory, add it to the device list, and modify the device name to LFP3-AP (Must match the name in the search for PROFINET devices), the IP address assigned to LFC3-AP simultaneously is 192.168.6.6 (located in the same network segment as the PLC's IP). After completing the modifications, click "Next".

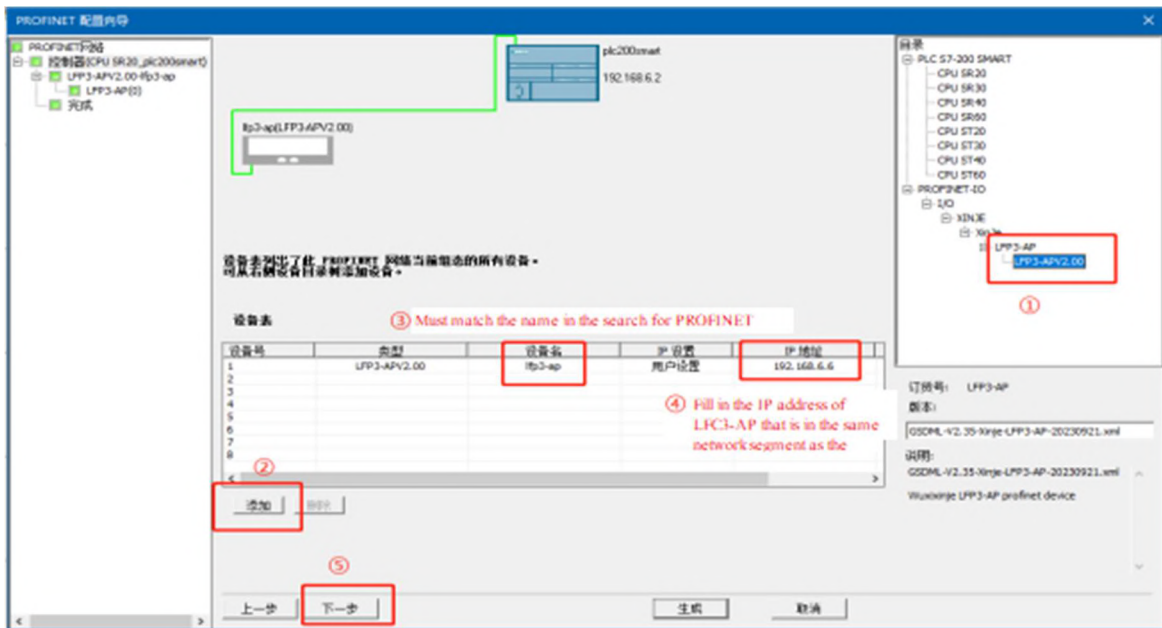

6. According to the IO module model attached after LFP3-AP, manually add the corresponding module. You can view the addresses and lengths occupied by each module in the PLC, and click "Next".

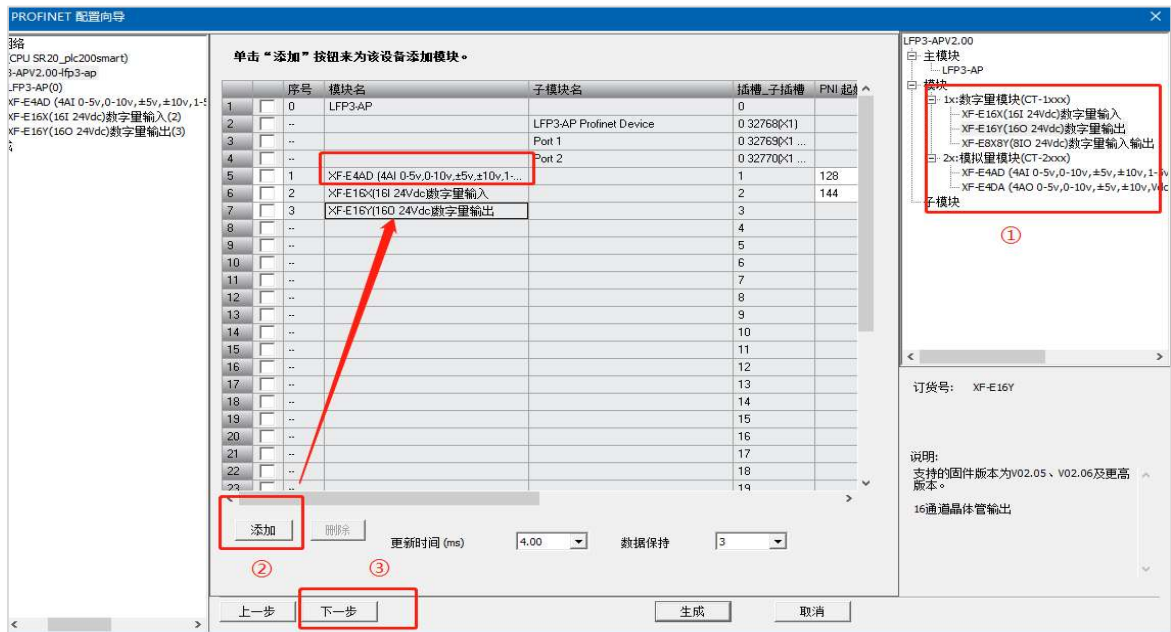

7. For the parameter description of LFP3-AP, click "Next directly".

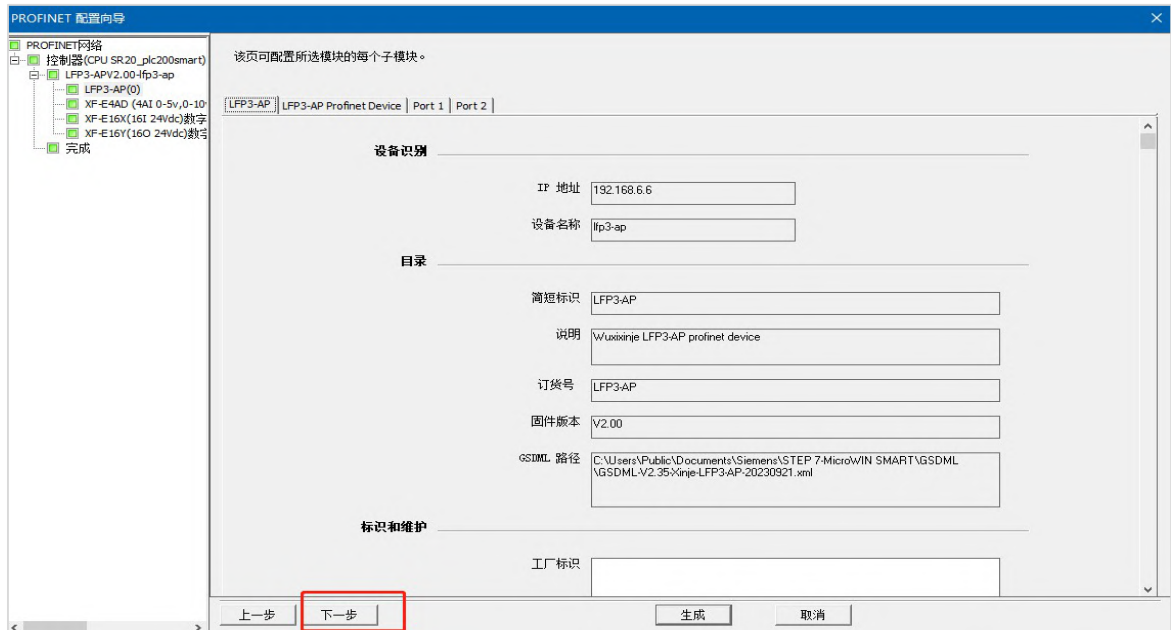

8. Parameters can be configured for each module, and detailed configuration instructions can be found in the manuals of each module. After configuration is completed, click "Production".

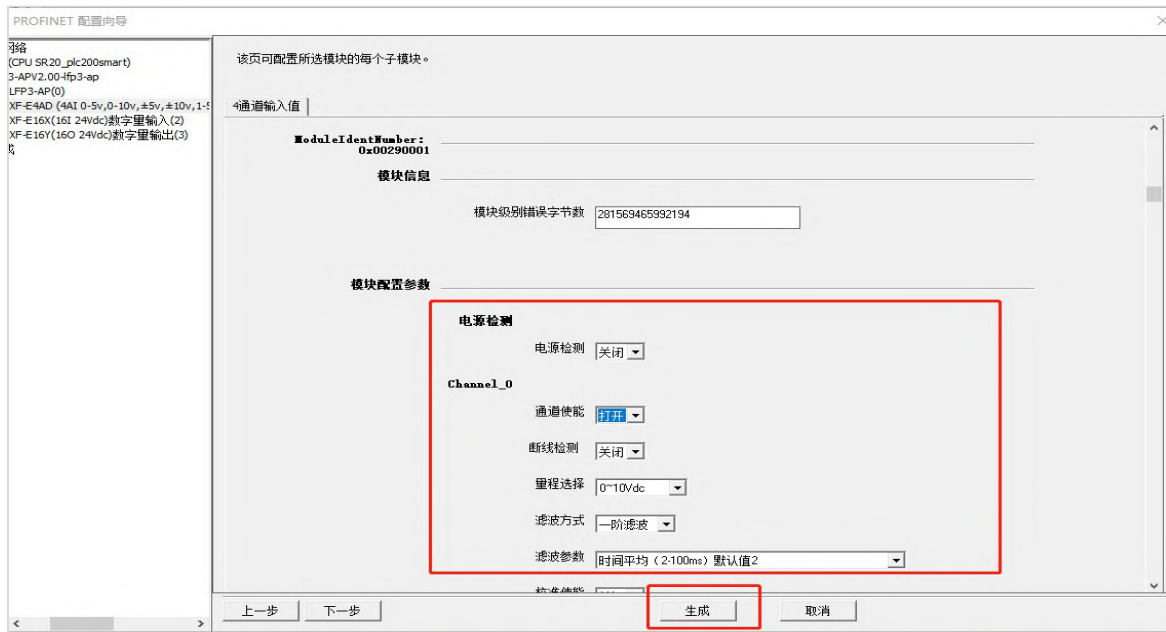

9. Click download in the "PLC" menu, select all block downloads, and click "Download". After downloading, check if the RUN indicator light of LFP3-AP is always on, which indicates a successful connection and normal operation.

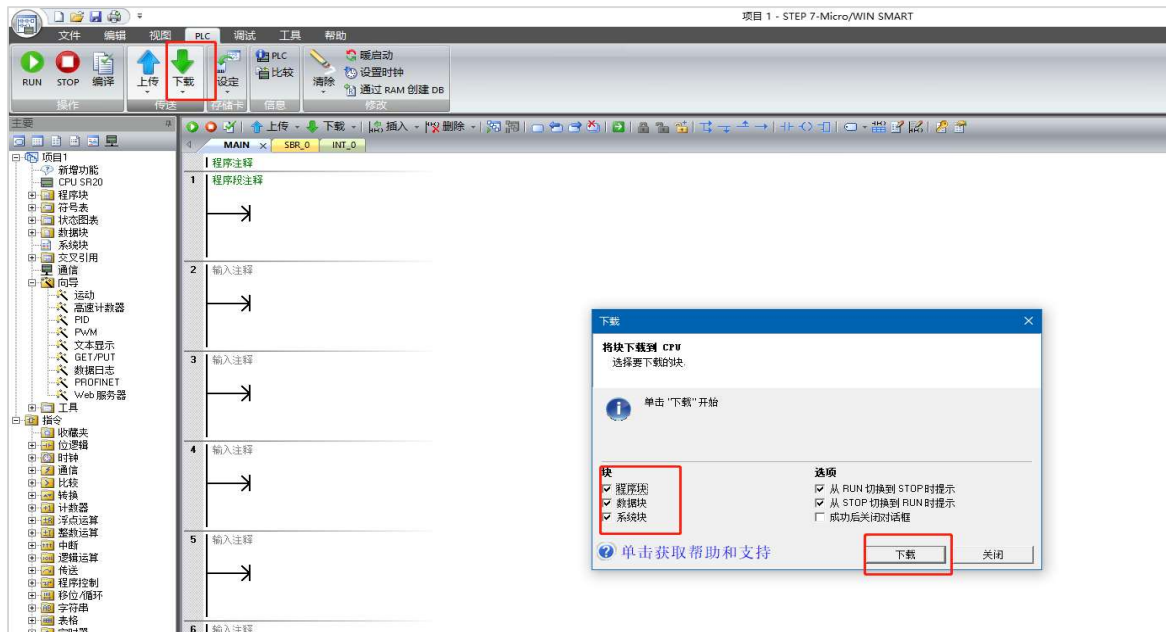

4. Digital quantity module unit

4.1 Naming rules

$\frac{\text{XF}}{\textcircled{1}} - \frac{\text{E}}{\textcircled{2}} \frac{\text{O}}{\textcircled{3}} \frac{\square}{\textcircled{4}} \frac{\text{X}}{\textcircled{5}} \frac{\square}{\textcircled{6}} \frac{\text{O}}{\textcircled{7}} \frac{\text{Y}}{\textcircled{8}} \frac{\square}{\textcircled{9}}$

①	Series name	XF:	XF series expansion module
②	Refers to the extension module	E:	Represents the right expansion module
③	Input channel	4:	4 channels
		8:	8 channels
		16:	16 channels
		32:	32 channels
		64:	64 channels
④	Input point type	Empty:	Digital input PNP&NPN compatible
		N:	Digital input NPN type
		P:	Digital input PNP type
⑤	Type	X:	Digital input
⑥	Output channel	4:	4 channels
		8:	8 channels
		16:	16 channels
		32:	32 channels
		64:	64 channels
⑦	Type of output	Empty:	Digital output NPN type
		P:	Digital output PNP type
⑧	Type	Y:	Digital output
⑨	Output point type	T:	Digital output transistor type
		R:	Digital output relay type

4.2 Digital input unit XF-E16X

4.2.1 Overview

The XF-E16X series digital input expansion module has 16 channels of digital input, supports NPN and PNP inputs, and is compatible with XF, XSF series CPU units and XF series communication coupler units.

- 16 channel digital input.
- Complies with IEC-61131 input standard type 3.
- NPN&PNP bipolar input.
- 12mm width design.
- Module version

Hardware version	Firmware version	Function
H2.0	V2.0	Basic functions for the first official production

4.2.2 Module view

1) Description of each section

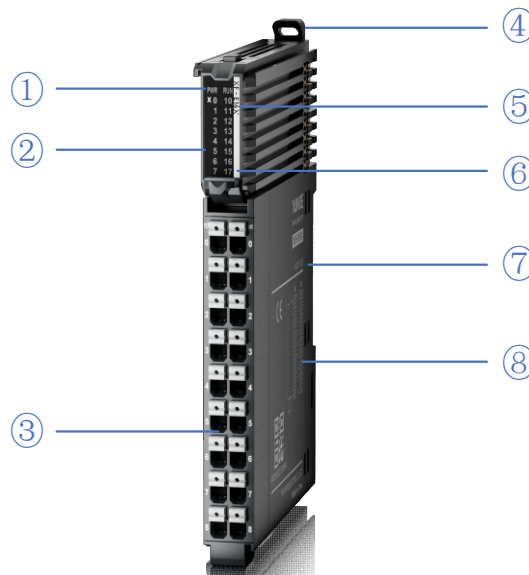

No.	Name	No.	Name
①	System LED indicator lights	②	Channel LED indicator light
③	Detachable terminal block	④	Snap
⑤	Model indication	⑥	Color identification indicating module type
⑦	Module hardware and firmware versions	⑧	Wiring diagram

2) System indicator

System indicator	Explanation	
PWR(Green)	Extinguish	Module not powered on
	Light	All external power supplies of the module are normal (Backplane bus power supply&external input 24V)
RUN(Green)	Light	The module is running normally
	Flash 1Hz* ¹	General errors in module logs
	Extinguish	Important errors in module logs
	Flash 10Hz* ²	Module establishing communication
	Double flashing* ³	Module firmware update

- *1: A square wave with a duty cycle of 50% and a frequency of 1Hz.
- *2: A square wave with a duty cycle of 50% and a frequency of 10Hz.
- *3: As shown in the following figure:

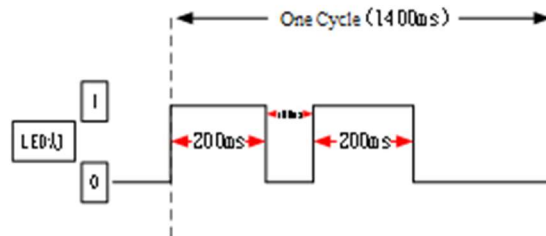

3) Channel indicator light

Model	Channel indicator light		
XF-E16X	X0-X17	Light (Green)	Corresponding input channel has input ON signal
		Extinguish	Corresponding input channel has no input ON signal

4) Color identification

No.	Colour	Module type
1	White	Digital input
2	Grey	Digital output & Digital mixing module
3	Light blue	Analog input
4	Deep blue	Analog output

4.2.3 General specification

General specification		
Project	Specifications	
Operating temperature	Maximum temperature	55°C
	Minimum temperature	-20°C
Transportation/Storage temperature	Maximum temperature	70°C
	Minimum temperature	-40°C

General specification		
Project		Specifications
Environmental humidity (including operation/storage)	Upper limit	95%
	Lower limit	10%
IP code		IP20
Anti vibration		Compliant with IEC61131-2 Under intermittent vibration (frequency 5-9Hz, constant amplitude 3.5mm peak displacement) and (frequency 9-150Hz, constant acceleration 1.0g peak acceleration) Under continuous intermittent vibration (frequency 5-9Hz half amplitude 1.75mm displacement) and (frequency 9-150Hz constant acceleration 0.5g constant frame amplitude) Scan 10 times in X, Y, and Z directions
Impact resistance		Complies with IEC61131-2 standard The impact strength is 15G (peak) and the duration is 11ms. It is applied to three mutually perpendicular axes, and each axis is impacted 3 times (a total of 18 impacts)
Using environment		Non corrosive gas
Using altitude		0-2000 m
Overvoltage level		II: Compliant with IEC61131-2
Pollution level		2: Compliant with IEC61131-2
Anti interference EMC		Compliant with IEC 61131-2 IEC61000-6-4 Type B
Related certifications		CE

4.2.4 Technical specifications

Project	Specifications
Input	16
Rated input voltage	DC24V
Rated input current	6mA
Input ON voltage	11v
Input ON current	2.5mA
Input OFF voltage	5v
Input OFF current	1mA
Input resistor ON → OFF response time (hardware)	20us
Input resistor OFF → ON response time (hardware)	100us
Input derating	Derate by 75% when operating at 60 °C (with no more than 12 ON input points), or by 10 °C when all input points are ON
Public end method	8 ports 1 public terminal
Wiring method	See external terminal connection diagram
Module power consumption	1.3W
Module weight	80g

4.2.5 Installation&Wiring

4.2.5.1 Appearance dimension diagram

(Unit: mm)

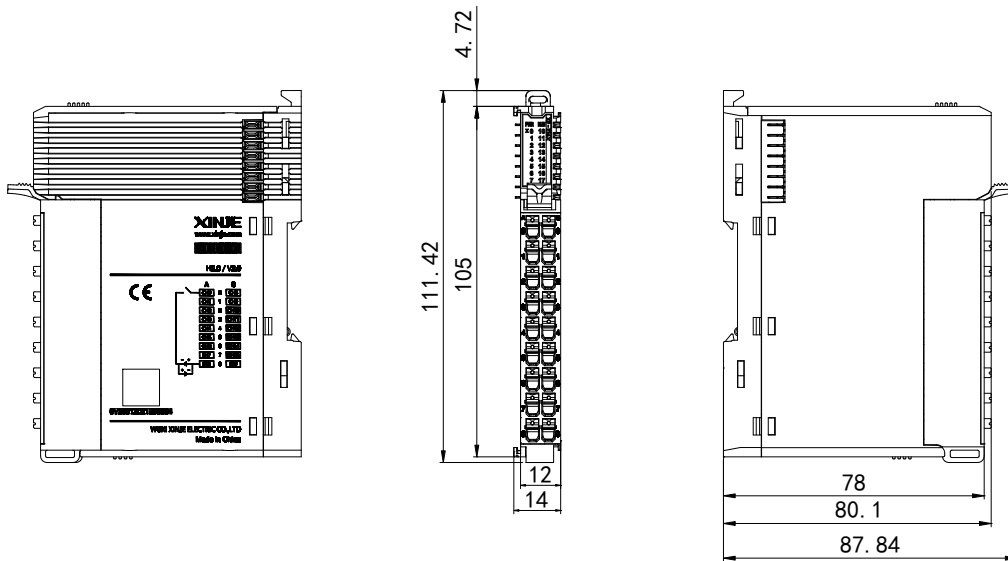

4.2.5.2 Terminal definition&Wiring

■ Terminal definition

XF-E16X					
Meaning	A-column terminal	Terminal layout	B-column terminal	Meaning	
CH0	0		0	CH8	
CH1	1		1	CH9	
CH2	2		2	CH10	
CH3	3		3	CH11	
CH4	4		4	CH12	
CH5	5		5	CH13	
CH6	6		6	CH14	
CH7	7		7	7	CH15
SS	8		8	8	SS



Two SS have internal short circuits, so all input points of a single module can only choose between NPN or PNP.

■ External wiring

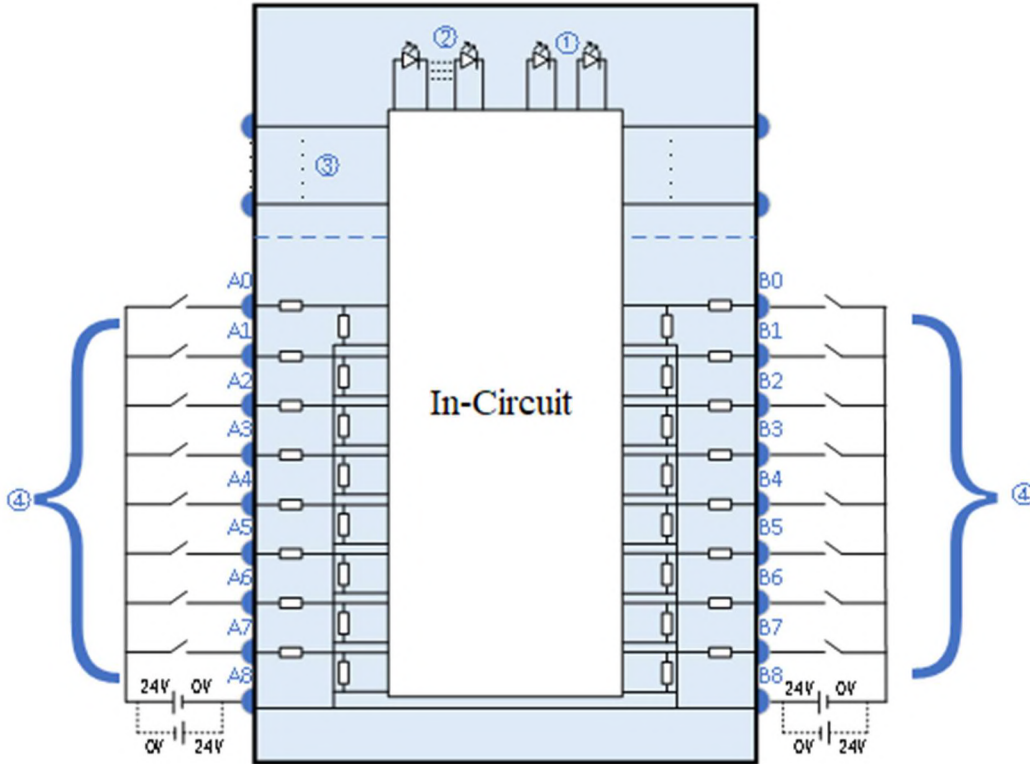

- ① System indicator ② Channel indicator light ③ Backplane bus ④ Input channels&wiring

4.2.5.3 Installation method

1) Installation requirements

The module is installed using DIN rails, which must comply with the IEC 60715 standard (35mm wide, 1mm thick), the size information is shown in the following figure, the unit is (mm).

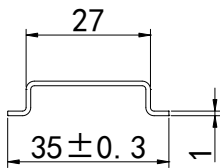

Note

When the module is installed on a non recommended DIN rail, the DIN rail latch may not lock properly.

2) Installation steps

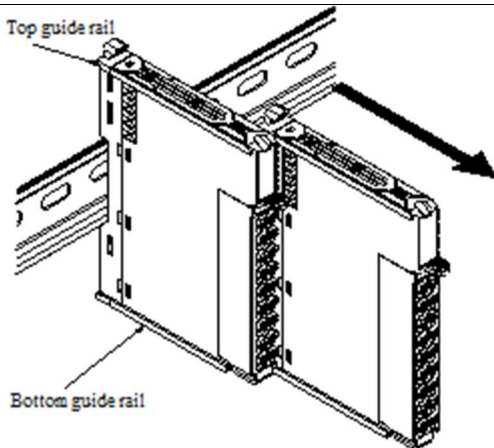

1. The assembly between IO modules is installed by sliding through the top and bottom guide rails of the modules, as shown in the left figure:

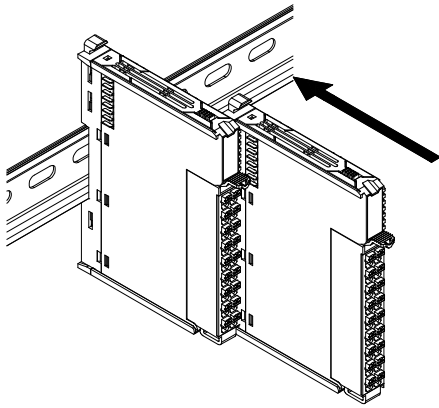

2. The module is installed on the rail, and during installation, align the module with the DIN rail, press the module in the direction indicated by the arrow, after installation, there is a noticeable snap sound, As shown in the left figure:

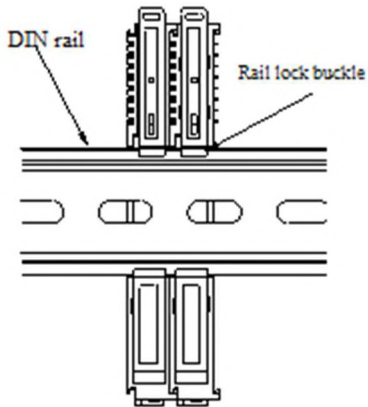

Explanation: After the module installation is completed, the locking buckle will automatically move downwards for locking, if the latch does not move downwards, press down on the top of the latch, ensure proper installation.

3) Disassembly steps

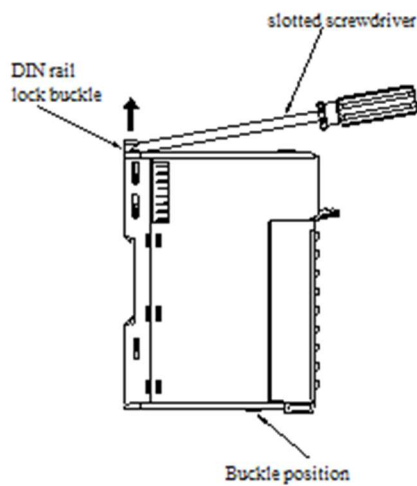

1. Use a flat screwdriver or similar tool to pry the rail lock upwards, as shown in the left figure:

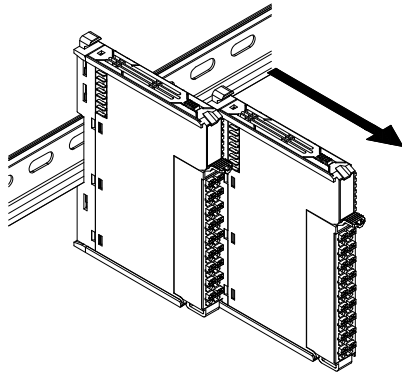

2. Pull the module straight forward at the buckle position (raised part), after completion, press down on the top of the latch, as shown in the left image:

4.2.5.4 Installation environment

This product can be installed in four positions (i.e. installation direction): horizontal, vertical, top of cabinet, and bottom of cabinet, it is recommended to install in a horizontal direction, and the heat dissipation design should be through natural convection, to ensure normal ventilation and heat dissipation, and to reserve sufficient wiring space, the minimum gap must be maintained around this product, as shown in the following figure:

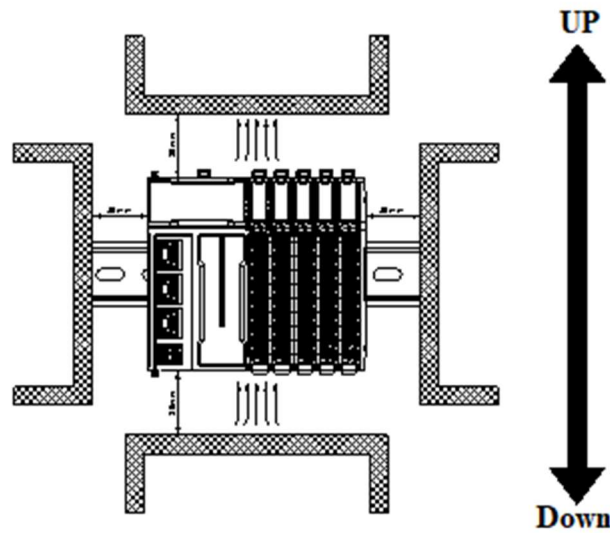

If there are high-temperature heat source equipment (heaters, transformers, large resistors, etc.) around this product, leave at least 100mm gap between the equipment and the high-temperature heat source.

4.2.5.5 Equipment wiring

When wiring the module, its terminal must meet the following requirements:

Adaptor diameter	
National standard/mm ²	American standard/AWG
0.3	22
0.5	20
0.75	18
1.0	18
1.5	16

If using other tube type wire ears, please crimp them to the twisted wire. The shape and size requirements are shown in the following figure:

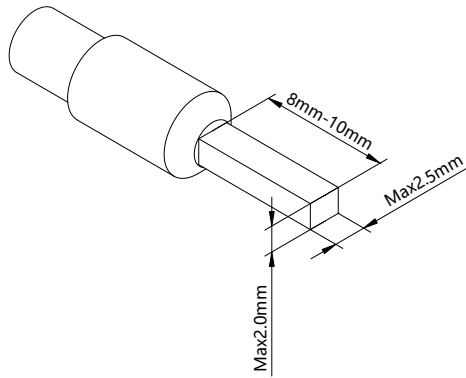

4.2.6 Usage of XF-E16X and LFC3-AP

4.2.6.1 Process data mapping (PDO)

Name	Type	Explanation
XF_E16X	Stuct	16 channel input module
CH0_X0	BOOL	Channel 0 input value
CH1_X1	BOOL	Channel 1 input value
CH2_X2	BOOL	Channel 2 input value
CH3_X3	BOOL	Channel 3 input value
CH4_X4	BOOL	Channel 4 input value
CH5_X5	BOOL	Channel 5 input value
CH6_X6	BOOL	Channel 6 input value
CH7_X7	BOOL	Channel 7 input value
CH8_X10	BOOL	Channel 8 input value
CH9_X11	BOOL	Channel 9 input value
CH10_X12	BOOL	Channel 10 input value
CH11_X13	BOOL	Channel 11 input value
CH12_X14	BOOL	Channel 12 input value
CH13_X15	BOOL	Channel 13 input value
CH14_X16	BOOL	Channel 14 input value
CH15_X17	BOOL	Channel 15 input value

4.2.6.2 Module configuration parameters (SDO)

Variable name	Type	Notes	
Channel 0 input filtering time	BYTE		
Channel 1 input filtering time	BYTE		
Channel 2 input filtering time	BYTE		
Channel 3 input filtering time	BYTE	0: No filtering	11: 9ms
Channel 4 input filtering time	BYTE	1: 0.25ms	12: 10ms
Channel 5 input filtering time	BYTE	2: 0.5ms	13: 11ms
Channel 6 input filtering time	BYTE	3: 1ms (Default)	14: 12ms
Channel 7 input filtering time	BYTE	4: 2ms	15: 13ms
Channel 8 input filtering time	BYTE	5: 3ms	16: 14ms
Channel 9 input filtering time	BYTE	6: 4ms	17: 15ms
Channel 10 input filtering time	BYTE	7: 5ms	18: 20ms
Channel 11 input filtering time	BYTE	8: 6ms	19: 30ms
Channel 12 input filtering time	BYTE	9: 7ms	20: 64ms
Channel 13 input filtering time	BYTE	10: 8ms	21: 128ms
Channel 14 input filtering time	BYTE		
Channel 15 input filtering time	BYTE		
Channel 0-7 logic level configuration	BYTE	0: Positive logic (default). 1: Negative logic	
Channel 8-15 logic level configuration	BYTE	bit0~bit7corresponds to channels 0~7 (bit8~bit15corresponds to channels 8~15)	

■ Channel input filtering time

"Filtering time" corresponds to a separate filtering parameter for each channel, and double-click the parameter name to configure the corresponding value.

Index:SubIndex	Name	Flag	Value	Communication error message
#x8001:00	Configuration Of 16X	rw	>18<	
-15	Channel 0 input filtering time	rw		Communication not established
-16	Channel 1 input filtering time	rw		Communication not established
-17	Channel 2 input filtering time	rw		Communication not established
-18	Channel 3 input filtering time	rw		Communication not established
-19	Channel 4 input filtering time	rw		Communication not established
-1A	Channel 5 input filtering time	rw		Communication not established
-1B	Channel 6 input filtering time	rw		Communication not established
-1C	Channel 7 input filtering time	rw		Communication not established
-1D	Channel 8 input filtering time	rw		Communication not established
-1E	Channel 9 input filtering time	rw		Communication not established
-1F	Channel 10 input filtering time	rw		Communication not established
-20	Channel 11 input filtering time	rw		Communication not established
-21	Channel 12 input filtering time	rw		Communication not established
-22	Channel 13 input filtering time	rw		Communication not established
-23	Channel 14 input filtering time	rw		Communication not established
-24	Channel 15 input filtering time	rw		Communication not established
-25	Channel 0-7 logic level configuration	rw		Communication not established
-26	Channel 8-15 logic level configuration	rw		Communication not established
#x9000:00	Information of 16X	ro	>17<	
#x9001:00	ErrorCode of 8X8Y	ro	>2<	

Parameter definition	When there is a signal at the input terminal and the signal duration exceeds the filtering time, it is considered as a valid signal
----------------------	---

Settable parameters	Configure the corresponding index objects in COE-Online, startup parameters, or SDO read and write instructions: unfiltered, 0.25ms, 0.5ms, 1ms, 2ms, 3ms, 4ms, 5ms, 6ms, 7ms, 8ms, 9ms, 10ms, 11ms, 12ms, 13ms, 14ms, 15ms, 20ms, 30ms, 64ms, 128ms
Default parameters	1ms

■ Channel logic level

"Logic level configuration" each channel corresponds to a separate logic level, and double-click on the parameter name to configure the corresponding value.

Index:SubIndex	Name	Flag	Value	Communication error message
#x8001:00	Configuration Of 16X	rw	>18<	
-15	Channel 0 input filtering time	rw		Communication not established
-16	Channel 1 input filtering time	rw		Communication not established
-17	Channel 2 input filtering time	rw		Communication not established
-18	Channel 3 input filtering time	rw		Communication not established
-19	Channel 4 input filtering time	rw		Communication not established
-1A	Channel 5 input filtering time	rw		Communication not established
-1B	Channel 6 input filtering time	rw		Communication not established
-1C	Channel 7 input filtering time	rw		Communication not established
-1D	Channel 8 input filtering time	rw		Communication not established
-1E	Channel 9 input filtering time	rw		Communication not established
-1F	Channel 10 input filtering time	rw		Communication not established
-20	Channel 11 input filtering time	rw		Communication not established
-21	Channel 12 input filtering time	rw		Communication not established
-22	Channel 13 input filtering time	rw		Communication not established
-23	Channel 14 input filtering time	rw		Communication not established
-24	Channel 15 input filtering time	rw		Communication not established
-25	Channel 0-7 logic level configuration	rw		Communication not established
-26	Channel 8-15 logic level configuration	rw		Communication not established
#x9000:00	Information of 16X	ro	>17<	
#x9001:00	ErrorCode of 8X8Y	ro	>2<	

Parameter definition	Program execution logic after external signal input			
	External input signal	Logic level configuration	Running programs	Operation result
	X0=1	Positive logic	LD X0. OUT Y0.	Y0=1
	X0=1	Negative logic		Y0=0
	X0=0	Positive logic		Y0=0
X0=0	Negative logic	Y0=1		
Settable parameters	Configure the corresponding index objects in COE-Online or startup parameters: positive logic (default), negative logic.			

4.2.7 Usage of XF-E16X and LFP3-AP

4.2.7.1 Process data mapping

In the device view, the mapping address of module process data can be viewed, with case mapping addresses ranging from I2.0-I3.7.

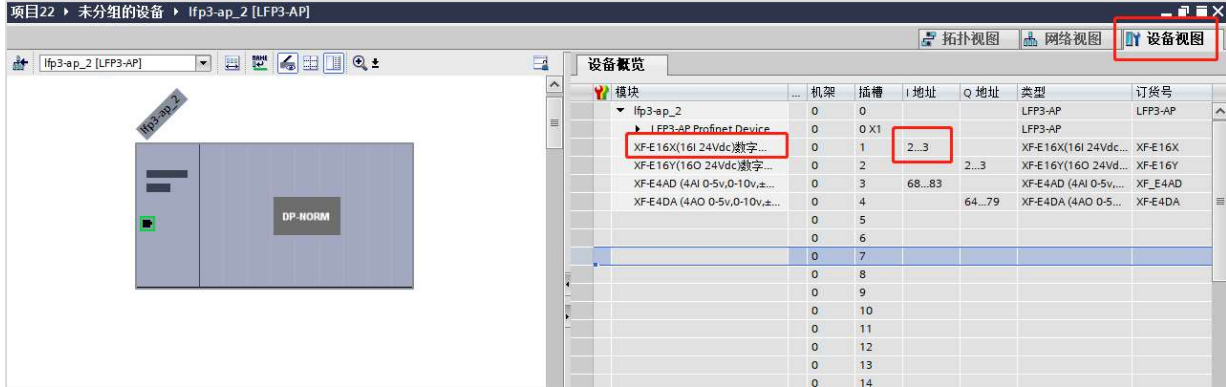

Name	Type	Explanation
XF_E16X	Stuct	16 channel input module
I2.0	BOOL	Channel 0 input value
I2.1	BOOL	Channel 1 input value
I2.2	BOOL	Channel 2 input value
I2.3	BOOL	Channel 3 input value
I2.4	BOOL	Channel 4 input value
I2.5	BOOL	Channel 5 input value
I2.6	BOOL	Channel 6 input value
I2.7	BOOL	Channel 7 input value
I3.0	BOOL	Channel 8 input value
I3.1	BOOL	Channel 9 input value
I3.2	BOOL	Channel 10 input value
I3.3	BOOL	Channel 11 input value
I3.4	BOOL	Channel 12 input value
I3.5	BOOL	Channel 13 input value
I3.6	BOOL	Channel 14 input value
I3.7	BOOL	Channel 15 input value

4.2.7.2 Module configuration parameters

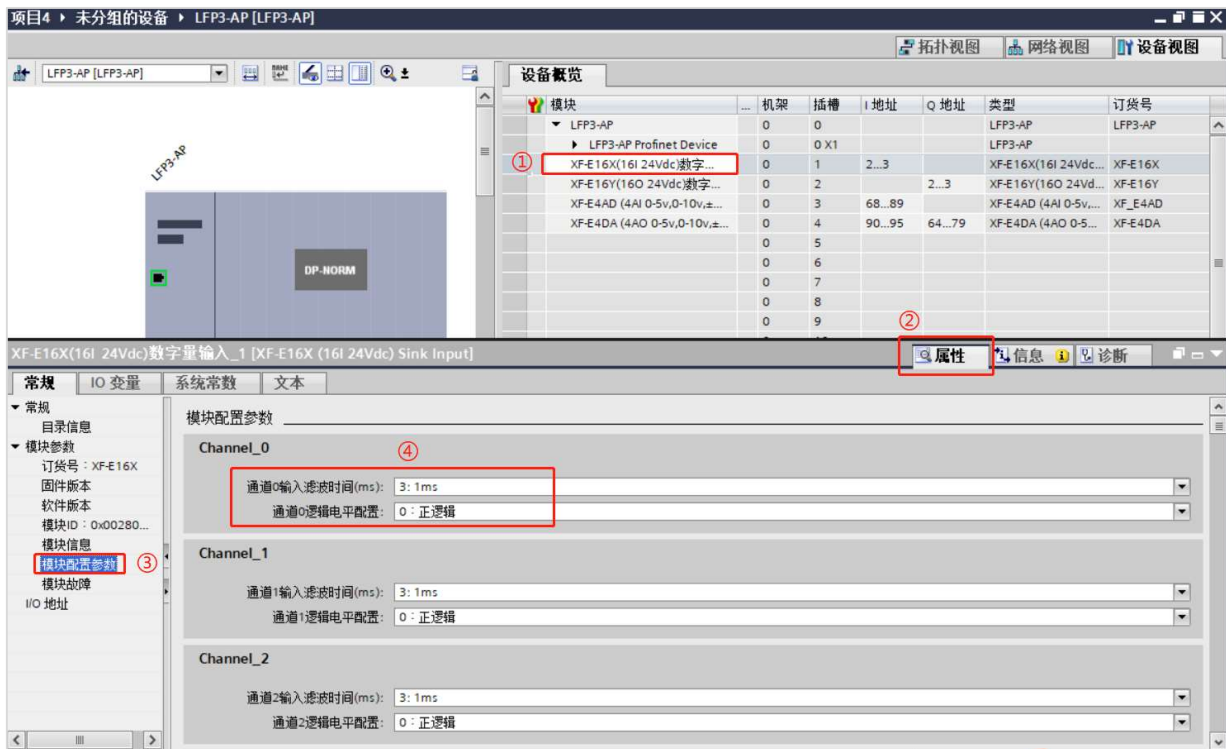

■ Channel input filtering time

"Filtering time" corresponds to a separate filtering parameter for each channel, and the setting method is to select the parameter from the drop-down menu.

Parameter definition	When there is a signal at the input terminal and the signal duration exceeds the filtering time, it is considered as an effective signal
Settable parameters	0ms, 0.25ms, 0.5ms, 1ms, 2ms, 3ms, 4ms, 5ms, 6ms, 7ms, 8ms, 9ms, 10ms, 11ms, 12ms, 13ms, 14ms, 15ms, 20ms, 30ms, 64ms, 128ms
Default parameters	1ms

■ Channel logic level

"Logic level configuration" Each channel corresponds to a separate logic level configuration. The setting method is to select parameters from the drop-down menu.

Parameter definition	Program execution logic after external signal input			
	External input signal	Logic level configuration	Running programs	Operation result
	X0=1	Positive logic	LD X0.	Y0=1
	X0=1	Negative logic	OUT Y0.	Y0=0
	X0=0	Positive logic		Y0=0
	X0=0	Negative logic		Y0=1
Settable parameters	The following table pulling method reflects the adjustable parameters: positive logic, negative logic			

4.3 Digital output unit XF-E16YT

4.3.1 Overview

XF-E16YT series digital output expansion module, which has 16 channels of digital output, support NPN output, compatible with XF, XSF series CPU unit products and XF series communication coupler units.

- 16 channel digital output.
- NPN output .
- Designed with a width of 12mm.
- Module version

Hardware version	Firmware version	Function
H2.0	V2.0	Basic functions for the first official production

4.3.2 Module view

1) Description of each section

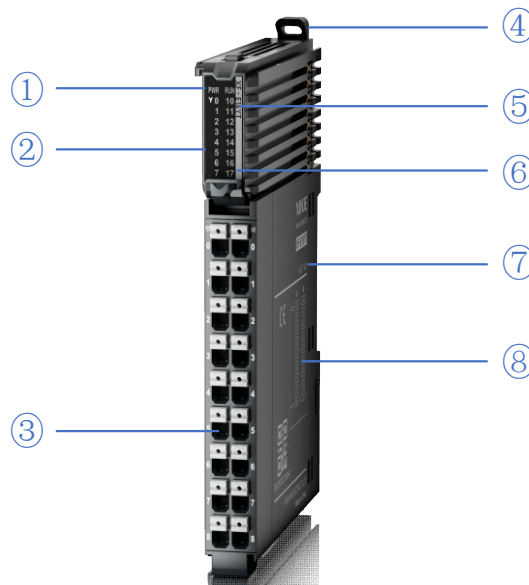

No.	Name	No.	Name
①	System LED indicator lights	②	Channel LED indicator light
③	Detachable terminal block	④	Snap
⑤	Model indication	⑥	Color identification indicating module type
⑦	Module hardware and firmware versions	⑧	Wiring diagram

2) System indicator

System indicator	Explanation	
PWR(Green)	Extinguish	Module not powered on
	Light	All external power supplies of the module are normal (backplane bus power supply&external input 24V)
	Flash1Hz* ¹	Abnormal power supply in the module and inability to operate normally
RUN(Green)	Light	The module is running normally
	Flash1Hz* ¹	General errors in module logs
	Extinguish	Important errors in module logs
	Flash10Hz* ²	Module establishing communication
	Double flashing* ³	Module firmware update

- *1: A square wave with a duty cycle of 50% and a frequency of 1Hz.
- *2: A square wave with a duty cycle of 50% and a frequency of 10Hz.
- *3: As shown in the following figure:

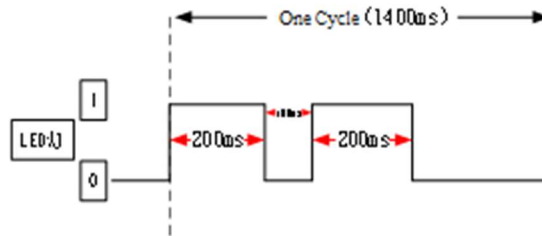

3) Channel indicator light

Model	Channel indicator light		
XF-E16YT	Y0-Y17	Light(Green)	Corresponding input channel has input ON signal
		Extinguish	Corresponding input channel has no input ON signal

4) Color identification

No.	Colour		Module type
1		White	Digital input
2		Grey	Digital output&digital mixing module
3		Light blue	Analog input
4		Deep blue	Analog output

4.3.3 General specification

General specification		
Project		Specifications
Operating temperature	Maximum temperature	55°C
	Minimum temperature	-20°C
Transportation/Storage Temperature	Maximum temperature	70°C
	Minimum temperature	-40°C

General specification		
Project		Specifications
Environmental humidity (including operation/storage)	Upper limit	95%
	Lower limit	10%
IP code		IP20
Anti vibration		Compliant with IEC61131-2 Under intermittent vibration (frequency 5-9Hz, constant amplitude 3.5mm peak displacement) and (frequency 9-150Hz, constant acceleration 1.0g peak acceleration) Under continuous intermittent vibration (frequency 5-9Hz half amplitude 1.75mm displacement) and (frequency 9-150Hz constant acceleration 0.5g constant frame amplitude) Scan 10 times in X, Y, and Z directions
Impact resistance		Complies with IEC61131-2 standard The impact strength is 15G (peak) and the duration is 11ms. It is applied to three mutually perpendicular axes, and each axis is impacted 3 times (a total of 18 impacts)
Using environment		Non corrosive gas
Using altitude		0-2000 m
Overvoltage level		II: Compliant with IEC61131-2
Pollution level		2: Compliant with IEC61131-2
Anti interference EMC		Compliant with IEC 61131-2 IEC61000-6-4 Type B
Related certifications		CE

4.3.4 Technical specifications

Project	Specifications
Output	16
Rated load voltage	DC24V(DC10.2V~28.8V)
Maximum load current	0.5A/1 point, 4A/module
Surge current protection	Support
Leakage current when OFF	Below 0.1mA
Maximum voltage drop during ON	0.5V~1V
Output ON → OFF response time (hardware)	0.1ms
Output OFF → ON response time (hardware)	0.1ms
Output derating	Reduce the rating by 50% when operating at 55 °C (while the output current of ON does not exceed 2A), or reduce the rating by 10 °C when the output point is fully ON
Public end method	16 ports 1 public terminal
Output protection	Supports short circuit and overload protection functions
Module power consumption	1.3W (backplane bus)+0.4W (external input)
Module weight	80g

4.3.5 Installation&Wiring

4.3.5.1 Appearance dimension diagram

(Unit: mm)

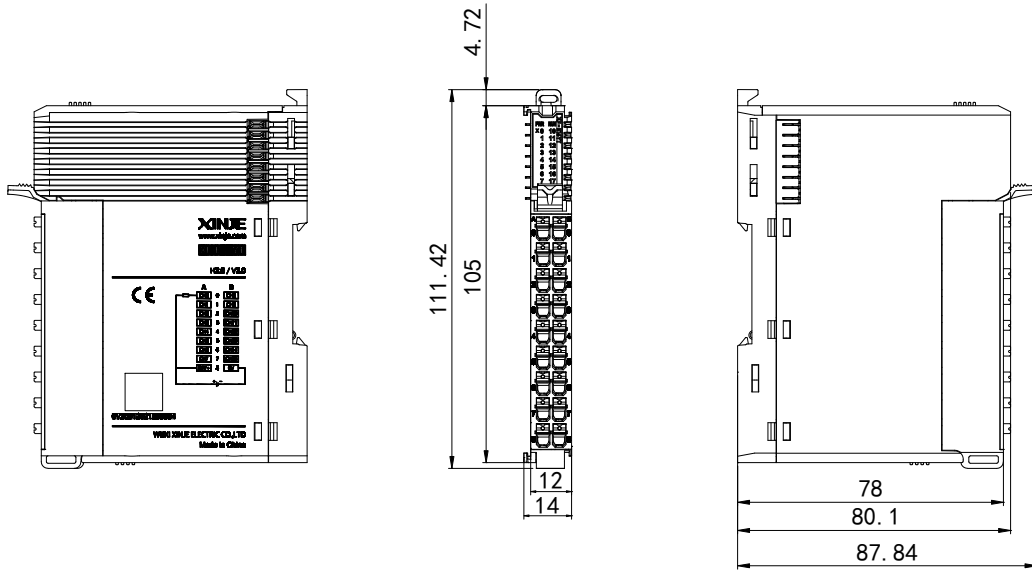

4.3.5.2 Terminal definition&Wiring

■ Terminal definition

XF-E16YT				
Meaning	A-column terminal	Terminal layout	B-column terminal	Meaning
CH0	0		0	CH8
CH1	1		1	CH9
CH2	2		2	CH10
CH3	3		3	CH11
CH4	4		4	CH12
CH5	5		5	CH13
CH6	6		6	CH14
CH7	7		7	CH15
24V+	8	8	8	0V

■ External wiring

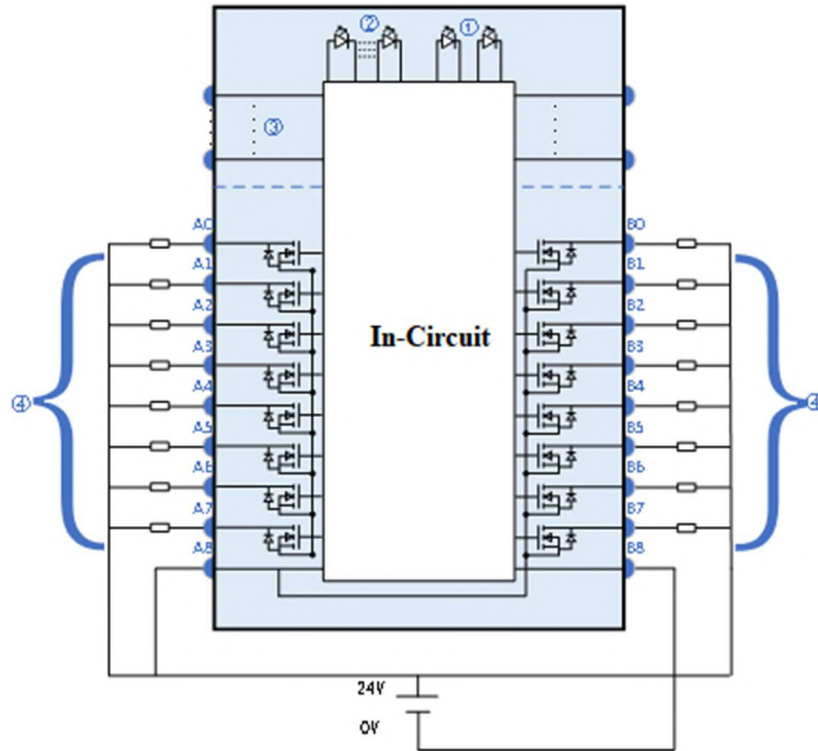

- ① System indicator ② Channel indicator light ③ Backplane bus ④ Output Channel&Wiring

4.3.5.3 Installation method

1) Installation requirements

The module is installed using DIN rails, which must comply with the IEC 60715 standard (35mm wide, 1mm thick), the size information is shown in the following figure, the unit is (mm).

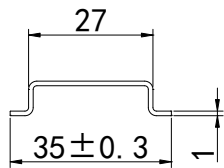

Note

When the module is installed on a non recommended DIN rail as mentioned above, the DIN rail latch may not lock properly.

2) Installation steps

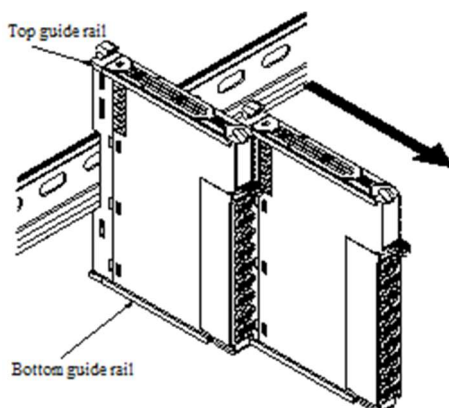

1. The assembly between IO modules is installed by sliding through the top and bottom guide rails of the modules, as shown in the left figure:

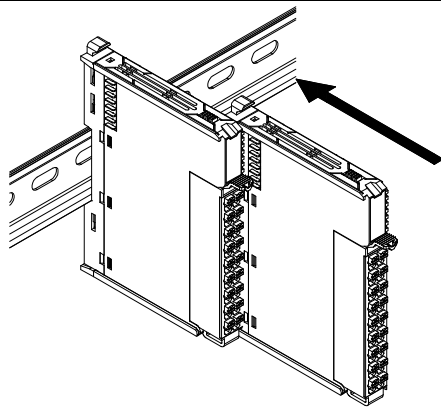

2. The module is installed on the guide rail, and during installation, align the module with the DIN rail and press the module in the direction indicated by the arrow, after installation, there is a noticeable snap sound, as shown in the left image:

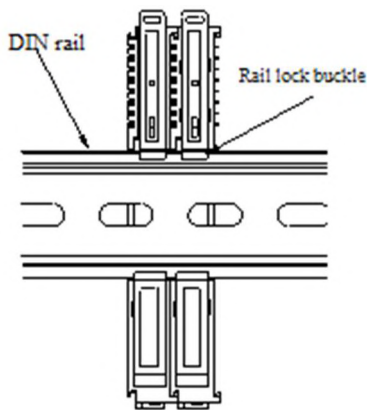

Explanation: After the module installation is completed, the locking buckle will automatically move downwards for locking, if the latch does not move downwards, press down on the top of the latch, ensure proper installation.

3) Disassembly steps

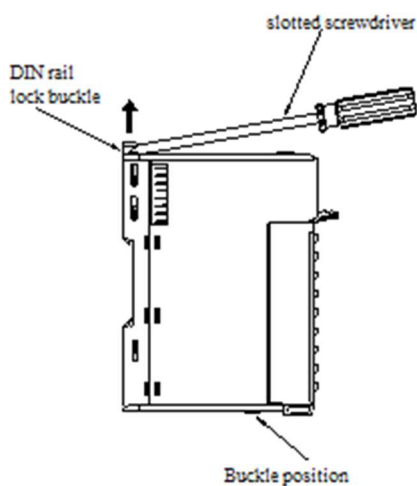

1. Use a flat screwdriver or similar tool to pry the rail lock upwards, as shown in the left figure:

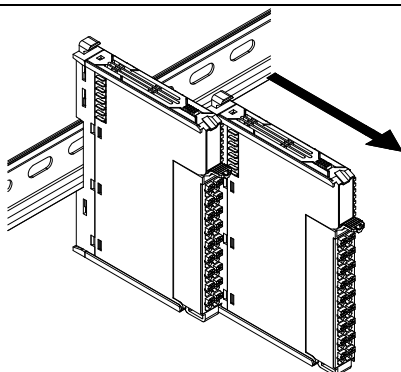

2. Pull the module straight forward at the buckle position (raised part), after completion, press down on the top of the latch, as shown in the left image:

4.3.5.4 Installation environment

This product can be installed in four positions (i.e. installation direction): horizontal, vertical, top of cabinet, and bottom of cabinet, it is recommended to install in a horizontal direction, and the heat dissipation design should be through natural convection, to ensure normal ventilation and heat dissipation, and to reserve sufficient wiring space, the minimum gap must be left around this product, as shown in the following figure:

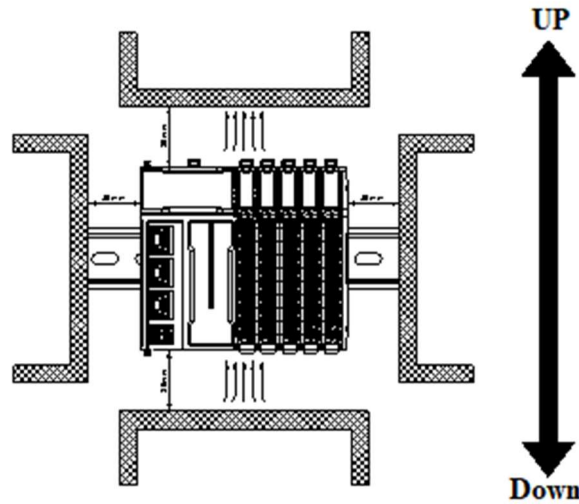

If there are high-temperature heat source equipment (heaters, transformers, large resistors, etc.) around this product, leave at least 100mm gap between the equipment and the high-temperature heat source.

4.3.5.5 Equipment wiring

When wiring the module, its terminal must meet the following requirements:

Adaptor diameter	
National standard/mm ²	American standard/AWG
0.3	22
0.5	20
0.75	18
1.0	18
1.5	16

If using other tube type wire ears, please crimp them to the twisted wire. The shape and size requirements are shown in the following figure:

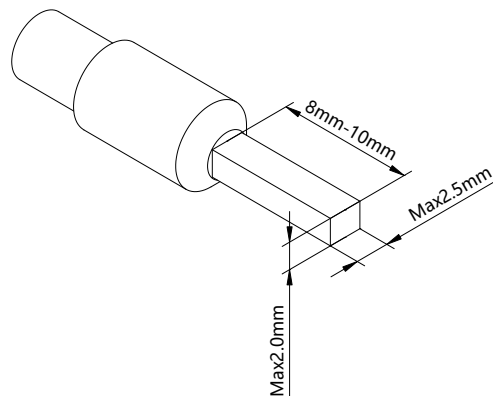

4.3.6 Usage of XF-E16Y and LFC3-AP

4.3.6.1 Process data mapping (PDO)

Name	Type	Explanation
XF_E16YT	Stuct	16 channel output module
— CH0_Y0	BOOL	Channel 0 output value
— CH1_Y1	BOOL	Channel 1 output value
— CH2_Y2	BOOL	Channel 2 output value
— CH3_Y3	BOOL	Channel 3 output value
— CH4_Y4	BOOL	Channel 4 output value
— CH5_Y5	BOOL	Channel 5 output value
— CH6_Y6	BOOL	Channel 6 output value
— CH7_Y7	BOOL	Channel 7 output value
— CH8_Y10	BOOL	Channel 8 output value
— CH9_Y11	BOOL	Channel 9 output value
— CH10_Y12	BOOL	Channel 10 output value
— CH11_Y13	BOOL	Channel 11 output value
— CH12_Y14	BOOL	Channel 12 output value
— CH13_Y15	BOOL	Channel 13 output value
— CH14_Y16	BOOL	Channel 14 output value
— CH15_Y17	BOOL	Channel 15 output value

4.3.6.2 Module configuration parameters (SDO)

Byte sequence number	Type	Note
Channel 0 output status in case of abnormality	BYTE	0: Output replacement value OFF (default) 1: Keep previous value 2: Output replacement value ON
Channel 1 output status in case of abnormality	BYTE	
Channel 2 output status in case of abnormality	BYTE	
Channel 3 output status in case of abnormality	BYTE	
Channel 4 output status in case of abnormality	BYTE	
Channel 5 output status in case of abnormality	BYTE	
Channel 6 output status in case of abnormality	BYTE	
Channel 7 output status in case of abnormality	BYTE	
Channel 8 output status in case of abnormality	BYTE	
Channel 9 output status in case of abnormality	BYTE	
Channel 10 output status in case of abnormality	BYTE	
Channel 11 output status in case of abnormality	BYTE	
Channel 12 output status in case of abnormality	BYTE	
Channel 13 output status in case of abnormality	BYTE	
Channel 14 output status in case of abnormality	BYTE	
Channel 15 output status in case of abnormality	BYTE	
Channel 0-7 logic level configuration	BYTE	0: Positive logic (default). 1: Negative logic
Channel 8-15 logic level configuration	BYTE	Bit0~bit7 corresponds to channels 0~7 (bit8~bit15 corresponds to channels 8~15)

■ Abnormal/STOP output status

"Abnormal/STOP output status" Each channel corresponds to a separate parameter, and double-click on the parameter name to configure the corresponding value.

Index:SubIndex	Name	Flag	Value	Communication error message
#x8011:00	Configuration Of 16y	rw	>18<	
-15	Output status when channel 0 is abnormal	rw		Communication not established
-16	Output status when channel 1 is abnormal	rw		Communication not established
-17	Output status when channel 2 is abnormal	rw		Communication not established
-18	Output status when channel 3 is abnormal	rw		Communication not established
-19	Output status when channel 4 is abnormal	rw		Communication not established
-1A	Output status when channel 5 is abnormal	rw		Communication not established
-1B	Output status when channel 6 is abnormal	rw		Communication not established
-1C	Output status when channel 7 is abnormal	rw		Communication not established
-1D	Output status when channel 8 is abnormal	rw		Communication not established
-1E	Output status when channel 9 is abnormal	rw		Communication not established
-1F	Output status when channel 10 is abnormal	rw		Communication not established
-20	Output status when channel 11 is abnormal	rw		Communication not established
-21	Output status when channel 12 is abnormal	rw		Communication not established
-22	Output status when channel 13 is abnormal	rw		Communication not established
-23	Output status when channel 14 is abnormal	rw		Communication not established
-24	Output status when channel 15 is abnormal	rw		Communication not established
-25	Channel 0-7 logic level configuration	rw		Communication not established
-26	Channel 8-15 logic level configuration	rw		Communication not established
#x9010:00	Information of 16y	ro	>17<	
#x9011:00	ErrorCode of 8X8Y	ro	>2<	

Parameter definition	Configure the corresponding index objects in COE-Online, startup parameters, or SDO read and write instructions: "Output replacement value OFF", "Keep previous value", "Output replacement value ON"	
Settable parameters	Output replacement value OFF	When the PLC is in STOP mode, the output terminal is in a reset state (physical terminal, regardless of channel logic level)
	Keep previous value	When the PLC is in abnormal/STOP mode, the output terminal outputs the last state of the PLC from RUN to STOP (physical terminal, regardless of channel logic level).
	Output replacement value ON	When the PLC is in abnormal/STOP mode, the output terminal is in the set state (physical terminal, regardless of channel logic level).
Default parameters	Output replacement value OFF	

■ Channel logic level

"Logic level configuration" each channel corresponds to a separate logic level, and double-click on the parameter name to configure the corresponding value.

Index:SubIndex	Name	Flag	Value	Communication error message
#x8011:00	Configuration Of 16y	rw	>18<	
-15	Output status when channel 0 is abnormal	rw		Communication not established
-16	Output status when channel 1 is abnormal	rw		Communication not established
-17	Output status when channel 2 is abnormal	rw		Communication not established
-18	Output status when channel 3 is abnormal	rw		Communication not established
-19	Output status when channel 4 is abnormal	rw		Communication not established
-1A	Output status when channel 5 is abnormal	rw		Communication not established
-1B	Output status when channel 6 is abnormal	rw		Communication not established
-1C	Output status when channel 7 is abnormal	rw		Communication not established
-1D	Output status when channel 8 is abnormal	rw		Communication not established
-1E	Output status when channel 9 is abnormal	rw		Communication not established
-1F	Output status when channel 10 is abnormal	rw		Communication not established
-20	Output status when channel 11 is abnormal	rw		Communication not established
-21	Output status when channel 12 is abnormal	rw		Communication not established
-22	Output status when channel 13 is abnormal	rw		Communication not established
-23	Output status when channel 14 is abnormal	rw		Communication not established
-24	Output status when channel 15 is abnormal	rw		Communication not established
-25	Channel 0-7 logic level configuration	rw		Communication not established
-26	Channel 8-15 logic level configuration	rw		Communication not established
#x9010:00	Information of 16y	ro	>17<	
#x9011:00	ErrorCode of 8X8Y	ro	>2<	

Parameter definition	Configure the corresponding index objects in COE-Online, startup parameters, or SDO read and write instructions: positive logic, negative logic													
Settable parameters	The program execution logic after external signal input.													
	<table border="1"> <thead> <tr> <th>Logic level configuration</th> <th>Running programs</th> <th>Operation result</th> </tr> </thead> <tbody> <tr> <td>Positive logic</td> <td rowspan="2">SET Y0.</td> <td>Y0 set to ON</td> </tr> <tr> <td>Negative logic</td> <td>Y0 set to OFF</td> </tr> <tr> <td>Positive logic</td> <td rowspan="2">RST Y0.</td> <td>Y0 set to OFF</td> </tr> <tr> <td>Negative logic</td> <td>Y0 set to ON</td> </tr> </tbody> </table>	Logic level configuration	Running programs	Operation result	Positive logic	SET Y0.	Y0 set to ON	Negative logic	Y0 set to OFF	Positive logic	RST Y0.	Y0 set to OFF	Negative logic	Y0 set to ON
	Logic level configuration	Running programs	Operation result											
	Positive logic	SET Y0.	Y0 set to ON											
	Negative logic		Y0 set to OFF											
Positive logic	RST Y0.	Y0 set to OFF												
Negative logic		Y0 set to ON												
Default parameters	Configure the corresponding index objects in COE-Online, startup parameters, or SDO read and write instructions: positive logic (default), negative logic.													

4.3.7 Usage of XF-E16Y and LFP3-AP

4.3.7.1 Process data mapping

In the device view, the mapping address of module process data can be viewed, with case mapping addresses ranging from Q2.0 to Q3.7.

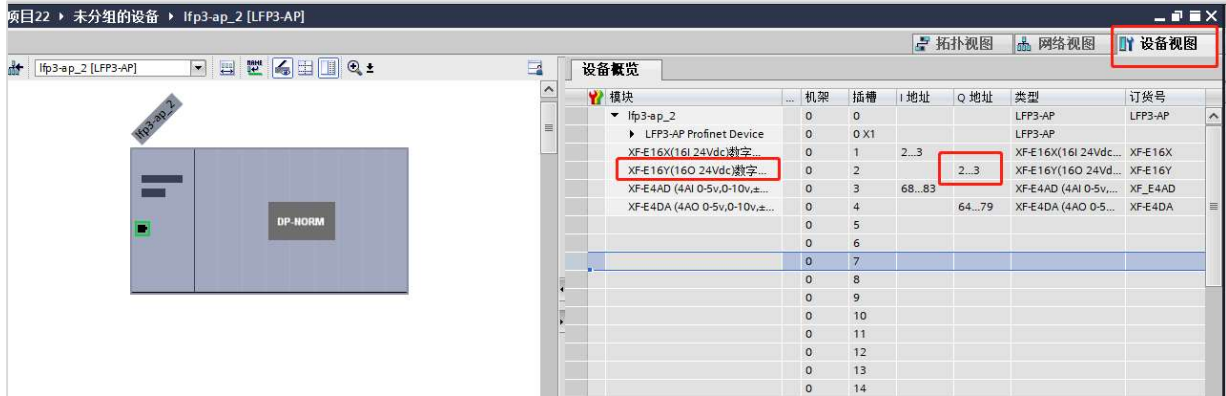

Name	Type	Explanation
XF_E16YT	Stuct	16 channel output module
Q2.0	BOOL	Channel 0 output value
Q2.1	BOOL	Channel 1 output value
Q2.2	BOOL	Channel 2 output value
Q2.3	BOOL	Channel 3 output value
Q2.4	BOOL	Channel 4 output value
Q2.5	BOOL	Channel 5 output value
Q2.6	BOOL	Channel 6 output value
Q2.7	BOOL	Channel 7 output value
Q3.0	BOOL	Channel 8 output value
Q3.1	BOOL	Channel 9 output value
Q3.2	BOOL	Channel 10 output value
Q3.3	BOOL	Channel 11 output value
Q3.4	BOOL	Channel 12 output value
Q3.5	BOOL	Channel 13 output value
Q3.6	BOOL	Channel 14 output value
Q3.7	BOOL	Channel 15 output value

4.3.7.2 Module configuration parameters

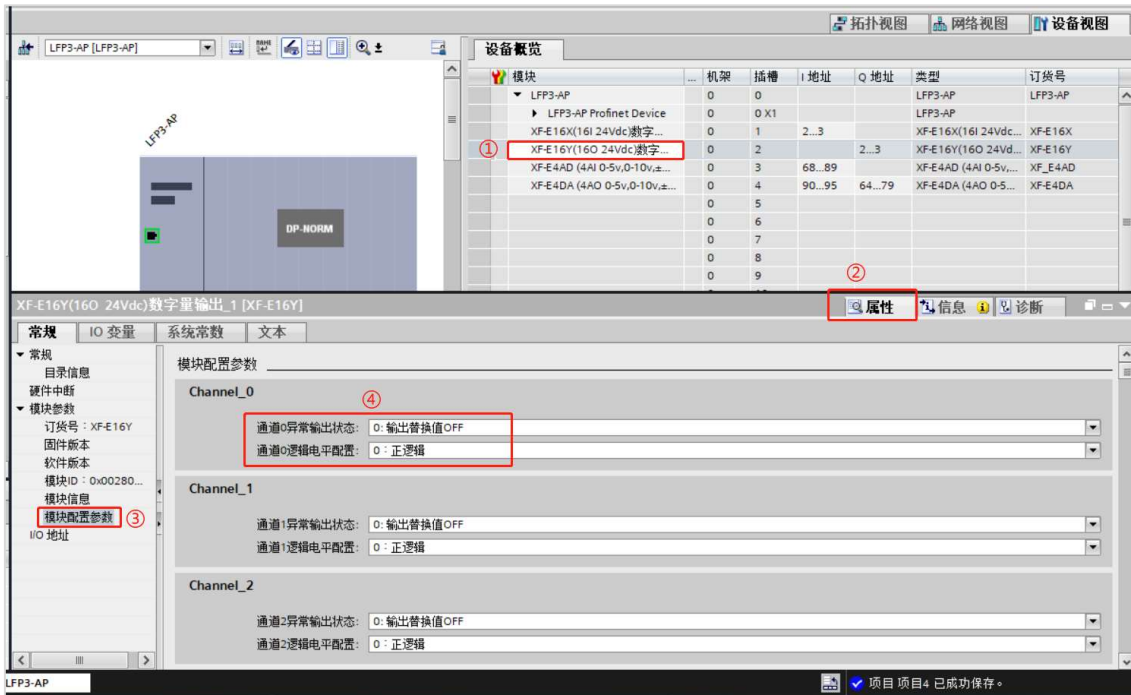

■ Abnormal/STOP output status

"Abnormal/STOP output status" each channel corresponds to a separate parameter, which can be set by selecting the parameter from the drop-down menu.

Parameter definition	The following table pulling method reflects the adjustable parameters: "Output replacement value OFF", "Keep previous value", "Output replacement value ON"	
Settable parameters	Output replacement value OFF	When the PLC is in STOP mode, the output terminal is in a reset state (physical terminal, regardless of channel logic level).
	Keep previous value	When the PLC is in abnormal/STOP mode, the output terminal outputs the last state of the PLC from RUN to STOP (physical terminal, regardless of channel logic level).
	Output replacement value ON	When the PLC is in abnormal/STOP mode, the output terminal is in the set state (physical terminal, regardless of channel logic level).
Default parameters	Output replacement value OFF	

■ Channel logic level

"Logic level configuration" Each channel corresponds to a separate logic level configuration. The setting method is to select parameters from the drop-down menu.

Parameter definition	The following table pulling method reflects the adjustable parameters: positive logic, negative logic		
Settable parameters	The program execution logic after external signal input.		
	Logic level configuration	Running programs	Operation result
	Positive logic	SET Y0.	Y0 set to ON
	Negative logic		Y0 set to OFF
	Positive logic	RST Y0.	Y0 set to OFF
Negative logic	Y0 set to ON		
Default parameters	The following table pulling method reflects the adjustable parameters: positive logic, negative logic		

4.4 Digital input output hybrid unit XF-E8NX8YT

4.4.1 Overview

XF-E8NX8YT series digital input output hybrid expansion module, which has 8 channels of digital input and supports NPN input. 8-channel digital output, supporting NPN output, compatible with XF, XSF series CPU units and XF series communication coupler units.

- 8-channel digital input.
- NPN type input.
- 8-channel digital output.
- NPN type output.
- 12mm width design.
- Module version

Hardware version	Firmware version	Function
H2.0	V2.0	Basic functions for the first official production

4.4.2 Module view

1) Description of each section

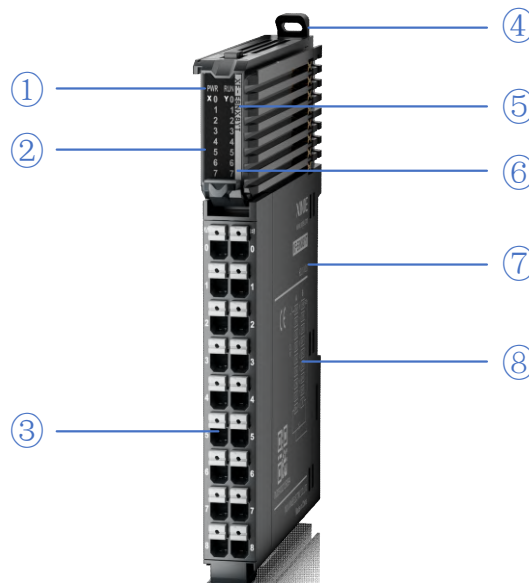

No.	Name	No.	Name
①	System LED indicator lights	②	Channel LED indicator light
③	Detachable terminal block	④	Snap
⑤	Model indication	⑥	Color identification indicating module type
⑦	Module hardware and firmware versions	⑧	Wiring diagram

2) System indicator

System indicator	Explanation	
PWR(Green)	Extinguish	Module not powered on
	Light	All external power supplies of the module are normal (backplane bus power supply&external input 24V)

System indicator	Explanation	
	Flash 1Hz* ¹	Abnormal power supply in the module and inability to operate normally
RUN(Green)	Light	The module is running normally
	Flash 1Hz* ¹	General errors in module logs
	Extinguish	Important errors in module logs
	Flash 10Hz* ²	Module establishing communication
	Double flashing* ³	Module firmware update

- *1: A square wave with a duty cycle of 50% and a frequency of 1Hz.
- *2: A square wave with a duty cycle of 50% and a frequency of 10Hz.
- *3: As shown in the following figure:

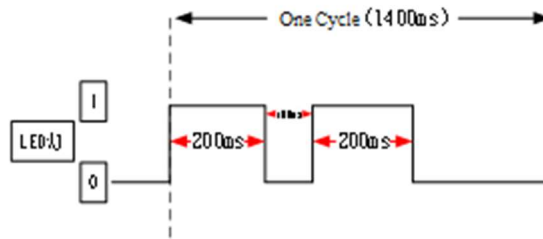

3) Channel indicator light

Model	Channel indicator light		
XF-E16X	X0-X7	Light (Green)	Corresponding input channel has input ON signal
	Y0-Y7	Extinguish	Corresponding input channel has no input ON signal

4) Color identification

No.	Colour		Module type
1		White	Digital input
2		Grey	Digital output&digital mixing module
3		Light blue	Analog input
4		Deep blue	Analog output

4.4.3 General specification

General specification		
Project	Specifications	
Operating temperature	Maximum temperature	55°C
	Minimum temperature	-20°C
Transportation/Storage Temperature	Maximum temperature	70°C
	Minimum temperature	-40°C
Environmental humidity (including operation/storage)	Upper limit	95%
	Lower limit	10%
IP code	IP20	

General specification	
Project	Specifications
Anti vibration	Compliant with IEC61131-2 Under intermittent vibration (frequency 5-9Hz, constant amplitude 3.5mm peak displacement) and (frequency 9-150Hz, constant acceleration 1.0g peak acceleration) Under continuous intermittent vibration (frequency 5-9Hz half amplitude 1.75mm displacement) and (frequency 9-150Hz constant acceleration 0.5g constant frame amplitude) Scan 10 times in X, Y, and Z directions
Impact resistance	Complies with IEC61131-2 standard The impact strength is 15G (peak) and the duration is 11ms. It is applied to three mutually perpendicular axes, and each axis is impacted 3 times (a total of 18 impacts)
Using environment	Non corrosive gas
Using altitude	0-2000 m
Overvoltage level	II: Compliant with IEC61131-2
Pollution level	2: Compliant with IEC61131-2
Anti interference EMC	Compliant with IEC 61131-2 IEC61000-6-4 Type B
Related certifications	CE

4.4.4 Technical specifications

Project		Specifications
Input specifications	Input channel	8
	Input type	NPN
	Rated input voltage	DC24V
	Rated input current	6mA
	Input ON voltage	15v
	Input ON current	3mA
	Input OFF voltage	5V
	Input OFF current	1mA
	Input derating	Reduce the rating by 50% when operating at 55 °C (with no more than 4 input points on simultaneously), or by 10 °C when all input points are on
	Input resistor ON → OFF response time (hardware)	20us
	Input resistor OFF → ON response time (hardware)	100us
Output specifications	Output channel	8
	Output type	Transistor (NPN)
	Rated load voltage	DC24V(DC10.2V~28.8V)
	Maximum load current	0.5A/1 point
	Surge current protection	Support
	Leakage current when OFF	Below 0.1mA
	Maximum voltage drop during ON	0.5A, 2A/module

Project		Specifications
	Output derating	Reduce the rating by 50% when operating at 55 °C (while the output current of ON does not exceed 2A), or reduce the rating by 10 °C when the output point is fully ON
	Input resistor ON → OFF response time (hardware)	100us
	Input resistor OFF → ON response time (hardware)	100us
Module specifications	Module power consumption	1.3W (backplane bus)+1.7W (external input)
	Module weight	80g

4.4.5 Terminal definition&Wiring

4.4.5.1 Appearance dimension diagram

(Unit: mm)

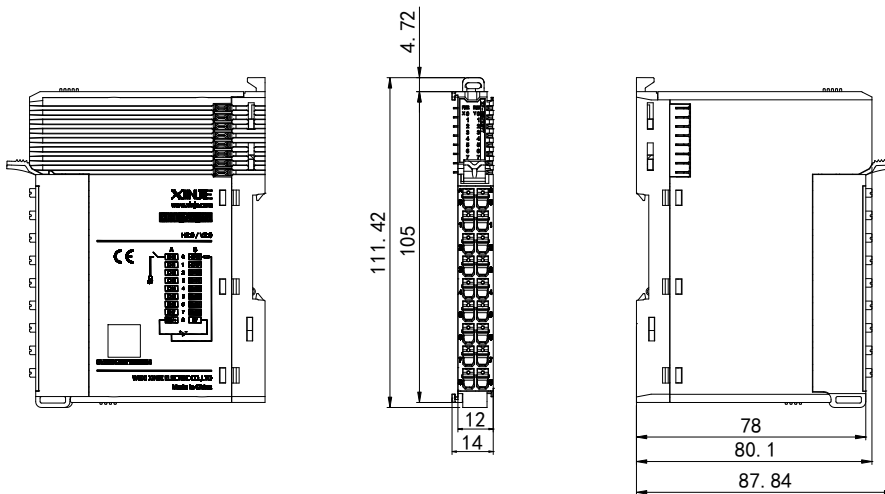

4.4.5.2 Terminal definition&Wiring

■ Terminal definition

XF-E8NX8YT				
Meaning	A-column terminal	Terminal layout	B-column terminal	Meaning
CH0	0		0	CH8
CH1	1		1	CH9
CH2	2		2	CH10
CH3	3		3	CH11
CH4	4		4	CH12
CH5	5		5	CH13
CH6	6		6	CH14
CH7	7		7	CH15
24V+	8		8	0V

■ External wiring

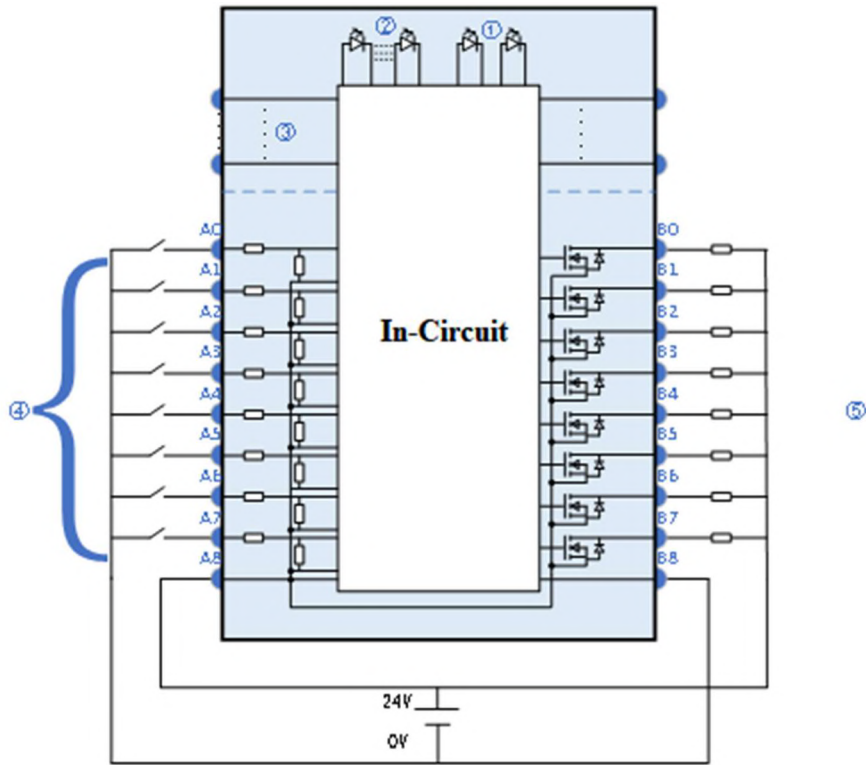

- ① System indicator ② Channel indicator light ③ Backplane bus ④ Input channels&wiring ⑤ Output Channel&Wiring

4.4.5.3 Installation method

1) Installation requirements

The module is installed using DIN rails, which must comply with the IEC 60715 standard (35mm wide, 1mm thick), the size information is shown in the following figure, in millimeters.

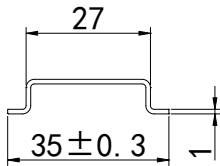

Note

When the module is installed on a non recommended DIN rail, the DIN rail latch may not lock properly.

2) Installation steps

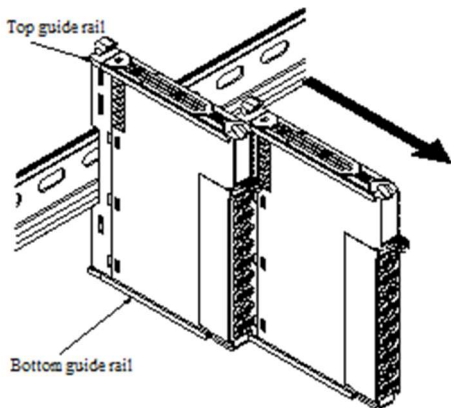

1. The assembly between IO modules is installed by sliding through the top and bottom guide rails of the modules, as shown in the left figure:

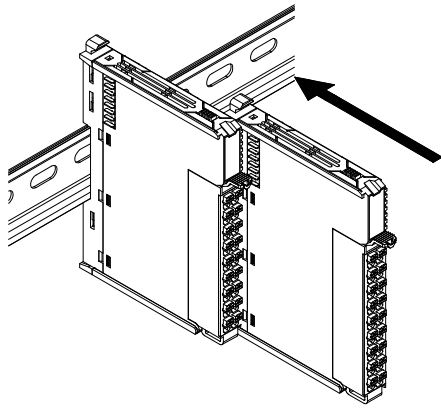

2. The module is installed on the guide rail. When installing, align the module with the DIN guide rail and press the module in the direction indicated by the arrow. After installation, there is a clear sound of engagement, as shown in the left figure:

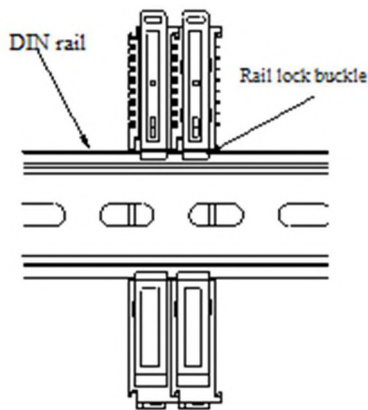

Explanation: After the module installation is completed, the latch will automatically move downwards to lock. If the latch does not move downwards, press down on the top of the latch to ensure proper installation.

3) Disassembly steps

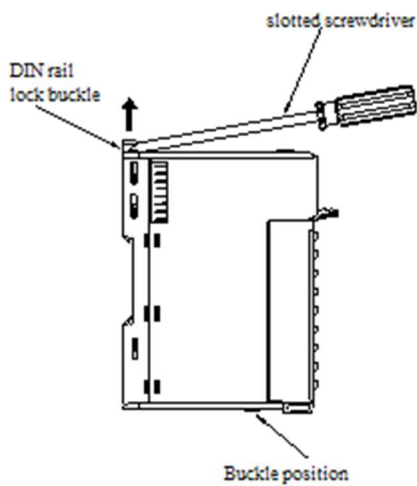

1. Use a flat screwdriver or similar tool to pry the rail lock upwards, as shown in the left figure:

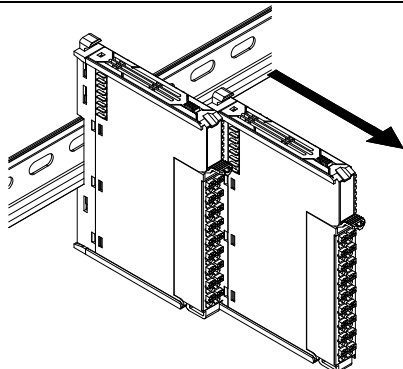

2. Pull the module straight forward at the buckle position (raised part), and then press down on the top of the latch, as shown in the left figure:

4.4.5.4 Installation environment

This product can be installed in four positions (i.e. installation direction): horizontal, vertical, top of cabinet, and bottom of cabinet. It is recommended to install in the horizontal direction, and the heat dissipation design is through natural convection. To ensure normal ventilation and heat dissipation and reserve sufficient wiring space, the minimum gap must be left around this product, as shown in the following figure:

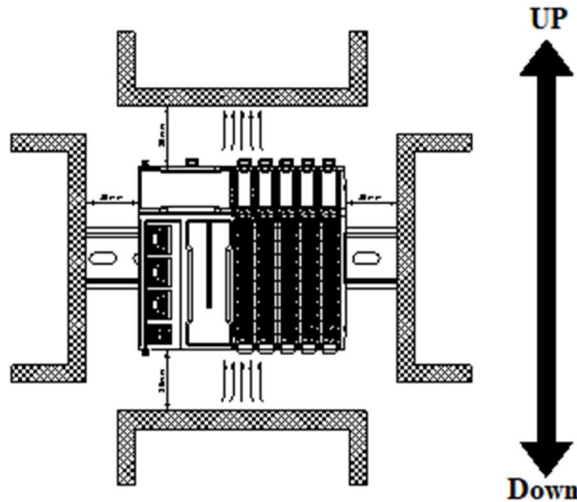

If there are high-temperature heat source equipment (heaters, transformers, large resistors, etc.) around this product, leave at least 100mm gap between the equipment and the high-temperature heat source.

4.4.5.5 Equipment wiring

When wiring the module, its terminal must meet the following requirements:

Adaptor diameter	
National standard/mm ²	American standard/AWG
0.3	22
0.5	20
0.75	18
1.0	18
1.5	16

If using other tube type wire ears, please crimp them to the twisted wire. The shape and size requirements are shown in the following figure:

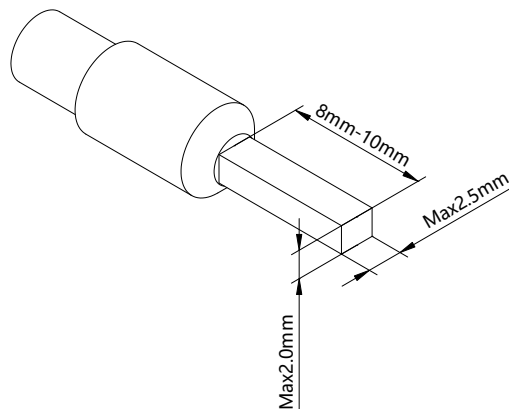

4.4.6 Usage of XF-E8NX8YT and LFC3-AP

4.4.6.1 Process data mapping (PDO)

Name	Type	Explanation
XF_E8X8Y	Stuct	8-channel input and 8-channel output module
— CH8_Y0	BOOL	Channel 8 output value
— CH9_Y1	BOOL	Channel 9 output value
— CH10_Y2	BOOL	Channel 10 output value
— CH11_Y3	BOOL	Channel 11 output value
— CH12_Y4	BOOL	Channel 12 output value
— CH13_Y5	BOOL	Channel 13 output value
— CH14_Y6	BOOL	Channel 14 output value
— CH15_Y7	BOOL	Channel 15 output value
— CH0_X0	BOOL	Channel 0 input value
— CH1_X1	BOOL	Channel 1 input value
— CH2_X2	BOOL	Channel 2 input value
— CH3_X3	BOOL	Channel 3 input value
— CH4_X4	BOOL	Channel 4 input value
— CH5_X5	BOOL	Channel 5 input value
— CH6_X6	BOOL	Channel 6 input value
— CH7_X7	BOOL	Channel 7 input value

4.4.6.2 Module configuration parameters (SDO)

Byte sequence number	Type	Note	
Channel 0 input filtering time	BYTE	0: No filtering	11: 9ms
Channel 1 input filtering time	BYTE	1: 0.25ms	12: 10ms
Channel 2 input filtering time	BYTE	2: 0.5ms	13: 11ms
Channel 3 input filtering time	BYTE	3: 1ms (Default)	14: 12ms
Channel 4 input filtering time	BYTE	4: 2ms	15: 13ms
Channel 5 input filtering time	BYTE	5: 3ms	16: 14ms
Channel 6 input filtering time	BYTE	6: 4ms	17: 15ms
Channel 7 input filtering time	BYTE	7: 5ms	18: 20ms
		8: 6ms	19: 30ms
		9: 7ms	20: 64ms
		10: 8ms	21: 128ms
Channel 8 output status in case of abnormality	BYTE	0: Output replacement value OFF (default) 1: Keep previous value 2: Output replacement value ON	
Channel 9 output status in case of abnormality	BYTE		
Channel 10 output status in case of abnormality	BYTE		
Channel 11 output status in case of abnormality	BYTE		
Channel 12 output status in case of abnormality	BYTE		
Channel 13 output status in case of abnormality	BYTE		
Channel 14 output status in case of abnormality	BYTE		
Channel 15 output status in case of abnormality	BYTE		
Channel 0-7 logic level configuration	BYTE	0: Positive logic (default). 1: Negative logic bit0~bit7corresponds to channels 0~7	
Channel 8-15 logic level configuration	BYTE	(bit8~bit15corresponds to channels 8~15)	

■ Channel input filtering time

"Filtering time" corresponds to a separate filtering parameter for each channel, and double-click the parameter name to configure the corresponding value.

Index:SubIndex	Name	Flag	Value	Communication error message
#x8011:00	Configuration Of 8X8Y	rw	>18<	
-15	Channel 0 input filtering time	rw		Communication not established
-16	Channel 1 input filtering time	rw		Communication not established
-17	Channel 2 input filtering time	rw		Communication not established
-18	Channel 3 input filtering time	rw		Communication not established
-19	Channel 4 input filtering time	rw		Communication not established
-1A	Channel 5 input filtering time	rw		Communication not established
-1B	Channel 6 input filtering time	rw		Communication not established
-1C	Channel 7 input filtering time	rw		Communication not established
-1D	Output status when channel 8 is abnormal	rw		Communication not established
-1E	Output status when channel 9 is abnormal	rw		Communication not established
-1F	Output status when channel 10 is abnormal	rw		Communication not established
-20	Output status when channel 11 is abnormal	rw		Communication not established
-21	Output status when channel 12 is abnormal	rw		Communication not established
-22	Output status when channel 13 is abnormal	rw		Communication not established
-23	Output status when channel 14 is abnormal	rw		Communication not established
-24	Output status when channel 15 is abnormal	rw		Communication not established
-25	Channel 0-7 logic level configuration	rw		Communication not established
-26	Channel 8-15 logic level configuration	rw		Communication not established

Parameter definition	When there is a signal at the input terminal and the signal duration exceeds the filtering time, it is considered as an effective signal
Settable parameters	Configure the corresponding index objects in COE-Online, startup parameters, or SDO read and write instructions: unfiltered, 0.25ms, 0.5ms, 1ms, 2ms, 3ms, 4ms, 5ms, 6ms, 7ms, 8ms, 9ms, 10ms, 11ms, 12ms, 13ms, 14ms, 15ms, 20ms, 30ms, 64ms, 128ms
Default parameters	1ms

■ Abnormal/STOP output status

"Abnormal/STOP output status" Each channel corresponds to a separate parameter, and double-click on the parameter name to configure the corresponding value.

Index:SubIndex	Name	Flag	Value	Communication error message
#x8011:00	Configuration Of 8X8Y	rw	>18<	
-15	Channel 0 input filtering time	rw		Communication not established
-16	Channel 1 input filtering time	rw		Communication not established
-17	Channel 2 input filtering time	rw		Communication not established
-18	Channel 3 input filtering time	rw		Communication not established
-19	Channel 4 input filtering time	rw		Communication not established
-1A	Channel 5 input filtering time	rw		Communication not established
-1B	Channel 6 input filtering time	rw		Communication not established
-1C	Channel 7 input filtering time	rw		Communication not established
-1D	Output status when channel 8 is abnormal	rw		Communication not established
-1E	Output status when channel 9 is abnormal	rw		Communication not established
-1F	Output status when channel 10 is abnormal	rw		Communication not established
-20	Output status when channel 11 is abnormal	rw		Communication not established
-21	Output status when channel 12 is abnormal	rw		Communication not established
-22	Output status when channel 13 is abnormal	rw		Communication not established
-23	Output status when channel 14 is abnormal	rw		Communication not established
-24	Output status when channel 15 is abnormal	rw		Communication not established
-25	Channel 0-7 logic level configuration	rw		Communication not established
-26	Channel 8-15 logic level configuration	rw		Communication not established

Parameter definition	Configure the corresponding index objects in COE-Online, startup parameters, or SDO read and write instructions: "Output replacement value OFF", "Keep previous value", "Output replacement value ON"	
Settable parameters	Output replacement value OFF	When the PLC is in STOP mode, the output terminal is in a reset state (physical terminal, regardless of channel logic level)
	Keep previous value	When the PLC is in abnormal/STOP mode, the output terminal outputs the last state of the PLC from RUN to STOP (physical terminal, regardless of channel logic level)
	Output replacement value ON	When the PLC is in abnormal/STOP mode, the output terminal is in the set state (physical terminal, regardless of channel logic level)
Default parameters	Output replacement value OFF	

■ Channel logic level

"Logic level configuration" Each channel corresponds to a separate logic level, and double-click on the parameter name to configure the corresponding value.

Index:SubIndex	Name	Flag	Value	Communication error message
#x8011:00	Configuration Of 8X8Y	rw	>18<	
-15	Channel 0 input filtering time	rw		Communication not established
-16	Channel 1 input filtering time	rw		Communication not established
-17	Channel 2 input filtering time	rw		Communication not established
-18	Channel 3 input filtering time	rw		Communication not established
-19	Channel 4 input filtering time	rw		Communication not established
-1A	Channel 5 input filtering time	rw		Communication not established
-1B	Channel 6 input filtering time	rw		Communication not established
-1C	Channel 7 input filtering time	rw		Communication not established
-1D	Output status when channel 8 is abnormal	rw		Communication not established
-1E	Output status when channel 9 is abnormal	rw		Communication not established
-1F	Output status when channel 10 is abnormal	rw		Communication not established
-20	Output status when channel 11 is abnormal	rw		Communication not established
-21	Output status when channel 12 is abnormal	rw		Communication not established
-22	Output status when channel 13 is abnormal	rw		Communication not established
-23	Output status when channel 14 is abnormal	rw		Communication not established
-24	Output status when channel 15 is abnormal	rw		Communication not established
-25	Channel 0-7 logic level configuration	rw		Communication not established
-26	Channel 8-15 logic level configuration	rw		Communication not established

Parameter definition	The following table pulling method reflects the adjustable parameters: positive logic, negative logic		
Settable parameters	Program execution logic after external signal input		
	Logic level configuration	Running programs	Operation result
	Positive logic	SET Y0.	Y0 set to ON
	Negative logic		Y0 set to OFF
	Positive logic	RST Y0.	Y0 set to OFF
	Negative logic		Y0 set to ON
Default parameters	Configure the corresponding index objects in COE-Online or startup parameters: positive logic (default), negative logic		

4.4.7 Usage of XF-E8NX8YT and LFP3-AP

4.4.7.1 Process data mapping

In the device view, the mapping addresses of module process data can be viewed, with case mapping addresses being I4.0-I4.7 and Q4.0-Q4.7.

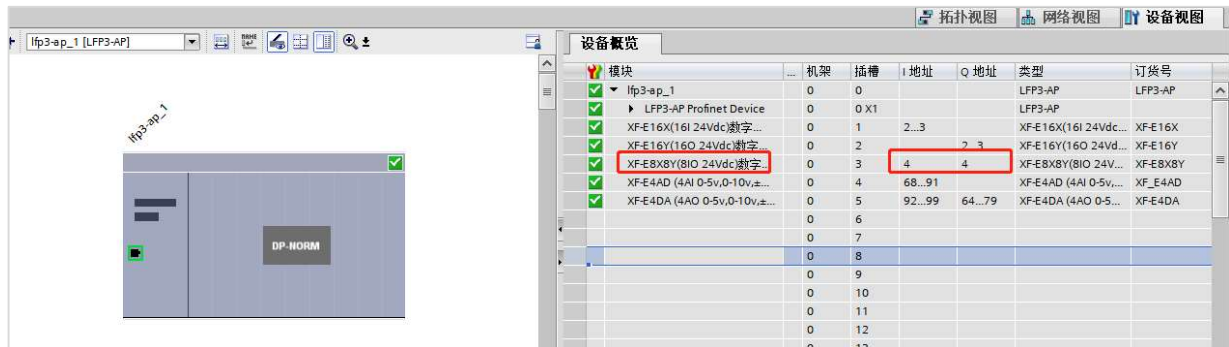

Name	Type	Explanation
XF_E8X8Y	Stuct	8-channel input and 8-channel output module
I4.0	BOOL	Channel 0 input value
I4.1	BOOL	Channel 1 input value
I4.2	BOOL	Channel 2 input value
I4.3	BOOL	Channel 3 input value
I4.4	BOOL	Channel 4 input value
I4.5	BOOL	Channel 5 input value
I4.6	BOOL	Channel 6 input value
I4.7	BOOL	Channel 7 input value
Q4.0	BOOL	Channel 8 input value
Q4.1	BOOL	Channel 9 input value
Q4.2	BOOL	Channel 10 input value
Q4.3	BOOL	Channel 11 input value
Q4.4	BOOL	Channel 12 input value
Q4.5	BOOL	Channel 13 input value
Q4.6	BOOL	Channel 14 input value
Q4.7	BOOL	Channel 15 input value

4.4.7.2 Module configuration parameters

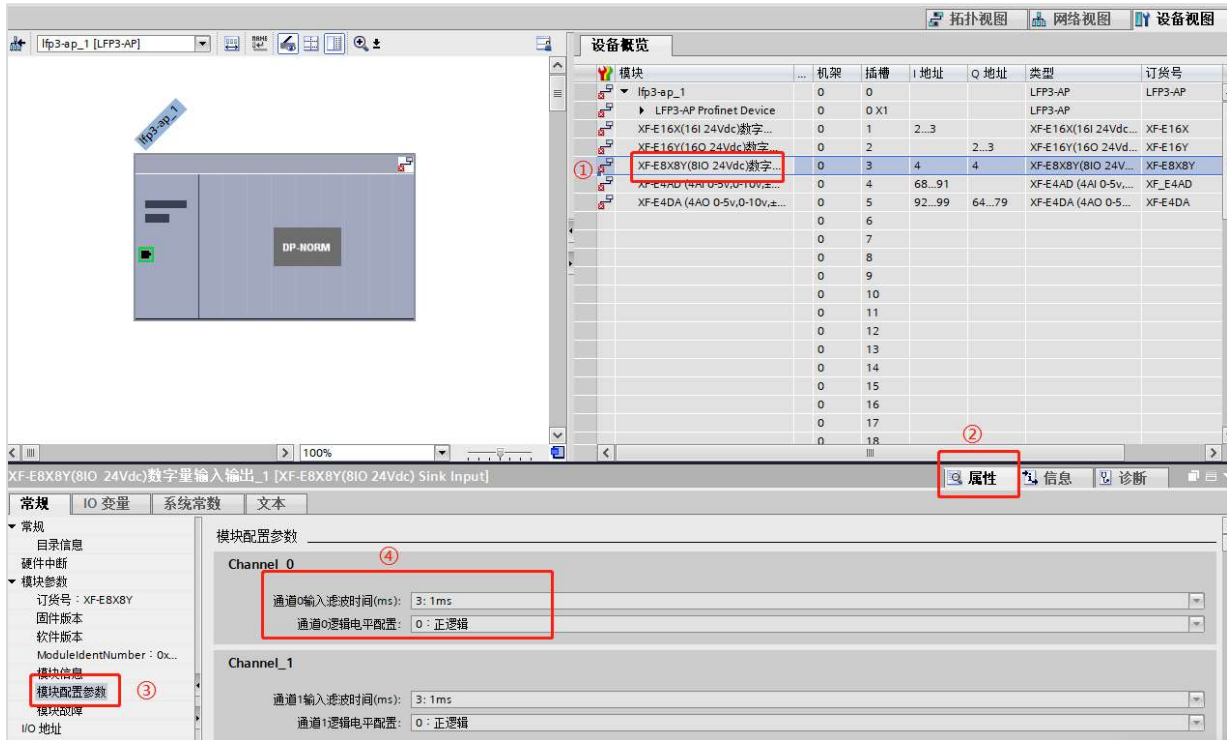

■ Channel input filtering time

"Filtering time" Each channel corresponds to a separate filtering parameter, which can be set by selecting the parameter from the drop-down menu.

Parameter definition	When there is a signal at the input terminal and the signal duration exceeds the filtering time, it is considered as an effective signal
Settable parameters	The following table pulling method reflects the adjustable parameters: No filtering , 0.25ms, 0.5ms, 1ms, 2ms, 3ms, 4ms, 5ms, 6ms, 7ms, 8ms, 9ms, 10ms, 11ms, 12ms, 13ms, 14ms, 15ms, 20ms, 30ms, 64ms, 128ms
Default parameters	1ms

■ Abnormal/STOP output status

"Abnormal/STOP output status" Each channel corresponds to a separate parameter, which can be set by selecting a parameter from the drop-down menu.

Parameter definition	The following table pulling method reflects the adjustable parameters: "Output replacement value OFF", "Keep previous value", "Output replacement value ON"	
Settable parameters	Output replacement value OFF	When the PLC is in STOP mode, the output terminal is in a reset state (physical terminal, regardless of channel logic level)
	Keep previous value	When the PLC is in abnormal/STOP mode, the output terminal outputs the last state of the PLC from RUN to STOP (physical terminal, regardless of channel logic level)
	Output replacement value ON	When the PLC is in abnormal/STOP mode, the output terminal is in the set state (physical terminal, regardless of channel logic level)
Default parameters	Output replacement value OFF	

■ Channel logic level

"Logic level configuration" Each channel corresponds to a separate logic level configuration. The setting method is to select parameters from the drop-down menu.

Parameter definition	The following table pulling method reflects the adjustable parameters: positive logic, negative logic		
Settable parameters	The program execution logic after external signal input.		
	Logic level configuration	Running programs	Operation result
	Positive logic	SET Y0.	Y0 set to ON
	Negative logic		Y0 set to OFF
	Positive logic	RST Y0.	Y0 set to OFF
Negative logic	Y0 set to ON		
Default parameters	The following table pulling method reflects the adjustable parameters: positive logic (default), negative logic		

5. Analog module unit

5.1 Naming rules

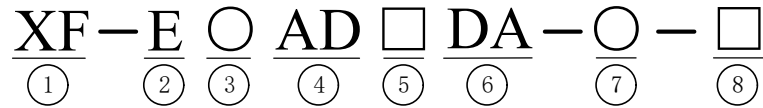

①	Series name	XF:	XF series expansion module
②	Refers to the extension module	E:	Represents the right expansion module
③	Input channel	1:	1 channel
		2:	2 channel
		4:	4 channel
		6:	6 channel
		8:	8 channel
④	Type	AD:	Indicates analog voltage and current input
⑤	Output channel	1:	1 channel
		2:	2 channel
		4:	4 channel
		6:	6 channel
		8:	8 channel
⑥	Type	DA:	Indicates analog voltage and current input
⑦	Analog quantity type	Empty:	Indicating current&voltage type
		A:	Indicating current type
		V:	Indicating voltage type
⑧	Module type	Empty:	General
		H:	Channel to channel isolation
		S:	High-precision
		U:	High speed

5.2 Analog input unit XF-E4AD

5.2.1 Overview

XF-E4AD series analog input expansion module, which has 4 channels of analog input, supports current and voltage inputs, adapt to XF, XSF series CPU unit products and XF series communication coupler units.

- 4-channel analog input.
- Channel conversion speed 60us/channel.
- Maximum 0.2% error.
- Voltage and current input.
- Designed with a width of 12mm.
- Module version

Hardware version	Firmware version	Function
H2.0	V2.0	Basic functions for the first official production

5.2.2 Module view

1) Description of each section

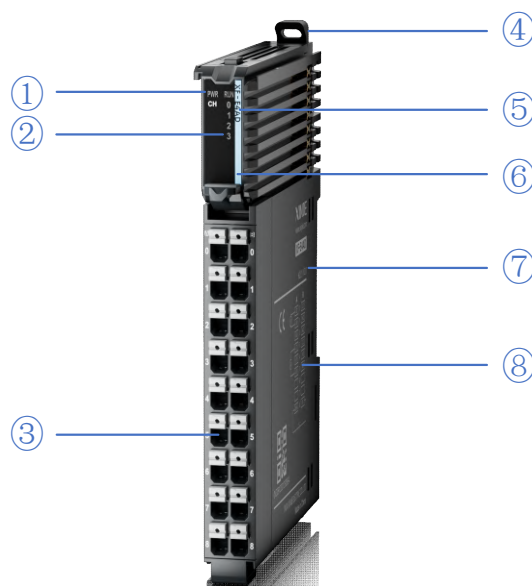

No.	Name	No.	Name
①	System LED indicator lights	②	Channel LED indicator light
③	Detachable terminal block	④	Snap
⑤	Model indication	⑥	Color identification indicating module type
⑦	Module hardware and firmware versions	⑧	Wiring diagram

2) System indicator

System indicator	Explanation	
PWR (Green)	Extinguish	Module not powered on
	Light	All external power supplies of the module are normal (backplane bus power supply & external input 24V)
	Flash1Hz* ¹	Abnormal power supply in the module and inability to operate normally
RUN (Green)	Light	The module is running normally
	Flash1Hz* ¹	General errors in module logs
	Extinguish	Important errors in module logs
	Flash10Hz* ²	Module establishing communication
	Double flashing* ³	Module firmware update

- *1: A square wave with a duty cycle of 50% and a frequency of 1Hz.
- *2: A square wave with a duty cycle of 50% and a frequency of 10Hz.
- *3: As shown in the following figure:

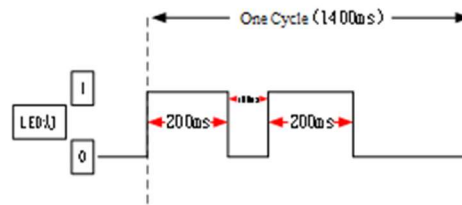

3) Channel indicator light

Model	Channel indicator light		
XF-E4AD	CH0~CH3	Light (Green)	Channel enabled and configured correctly
		Extinguish	Mute channel

4) Color identification

No.	Colour	Module type
1	White	Digital input
2	Grey	Digital output&digital mixing module
3	Light blue	Analog input
4	Deep blue	Analog output

5.2.3 General specification

General specification		
Project	Specifications	
Operating temperature	Maximum temperature	55°C
	Minimum temperature	-20°C
Transportation/Storage Temperature	Maximum temperature	70°C
	Minimum temperature	-40°C

Environmental humidity (including operation/storage)	Upper limit	95%
	Lower limit	10%
IP code		IP20
Anti vibration		Compliant with IEC61131-2 Under intermittent vibration (frequency 5-9Hz, constant amplitude 3.5mm peak displacement) and (frequency 9-150Hz, constant acceleration 1.0g peak acceleration) Under continuous intermittent vibration (frequency 5-9Hz half amplitude 1.75mm displacement) and (frequency 9-150Hz constant acceleration 0.5g constant frame amplitude) Scan 10 times in X, Y, and Z directions
Impact resistance		Complies with IEC61131-2 standard The impact strength is 15G (peak) and the duration is 11ms. It is applied to three mutually perpendicular axes, and each axis is impacted 3 times (a total of 18 impacts)
Using environment		Non corrosive gas
Using altitude		0-2000 m
Overvoltage level		II: Compliant with IEC61131-2
Pollution level		2: Compliant with IEC61131-2
Anti interference EMC		Compliant with IEC 61131-2 IEC61000-6-4 Type B
Related certifications		CE

5.2.4 Technical specifications

5.2.4.1 Module performance

Project		Specifications
Input channel		4
Analog input range (rated)	Voltage input range	0V~5V (0~64000) 0V~10V (0~64000) -5V~5V (-32000~32000) -10V~10V (-32000~32000) 1v~5v (12800~64000)
	Current input range	0mA~20mA (0~64000) 4mA~20mA (12800~64000) -20mA~20mA (-32000~32000)
Maximum input range	Voltage input	DC±15V
	Current input	-40~40mA
Conversion speed		60us/CH
Resolution ratio		1/64000 (16Bit)
Module power supply	Rated input	DC24V±10%, 150mA
	Protect	Reverse polarity protection
Error	Room temperature 25°C±5°C	±0.1% (25±5 °C)
	Full temperature end -20~55°C	±0.2%
Isolated		Channel non isolated, power isolated
Module power consumption		0.8W (backplane bus)+0.8W (external input)

5.2.4.2 Analog-to-digital conversion diagram

■ Voltage

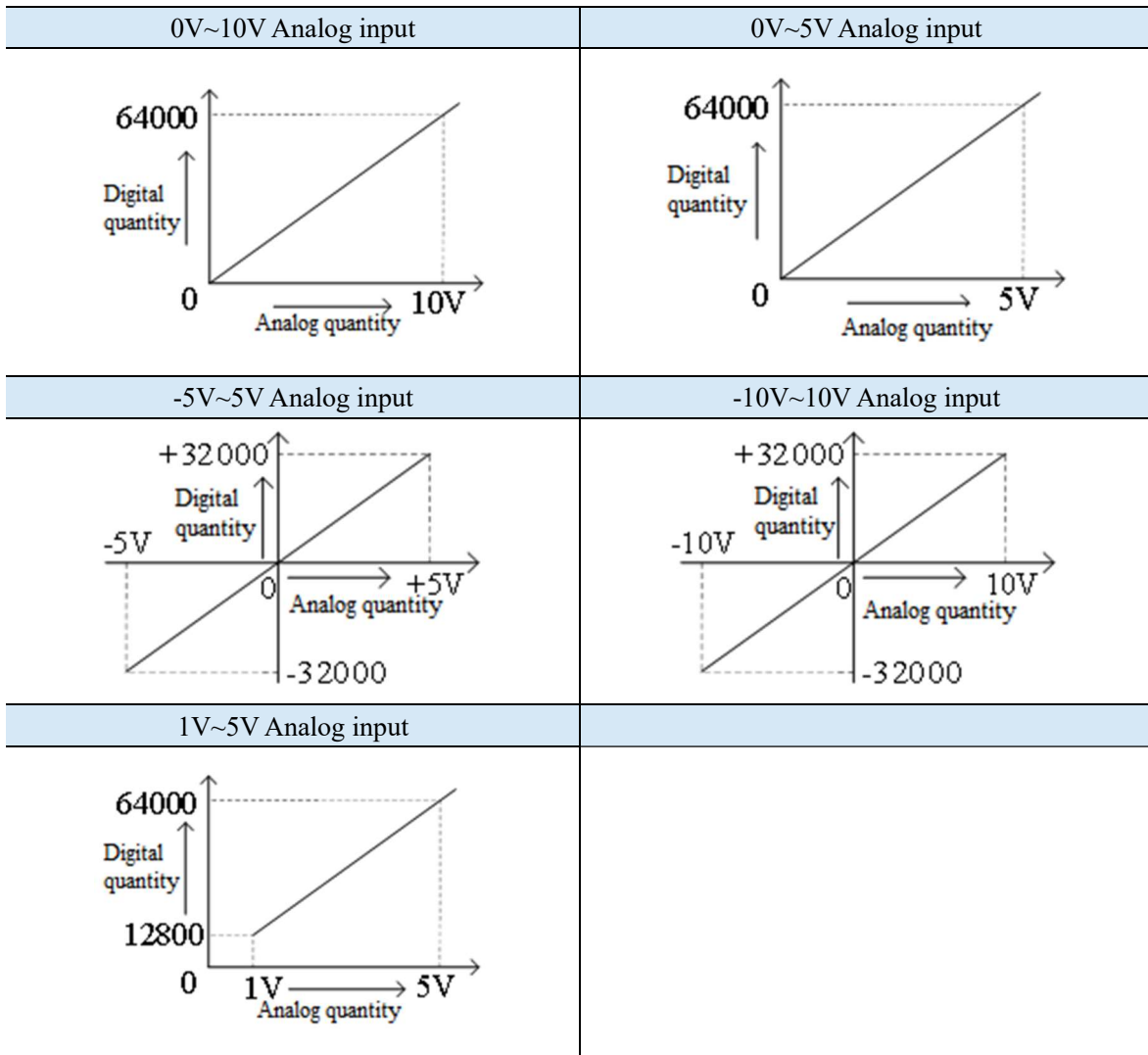

■ Current

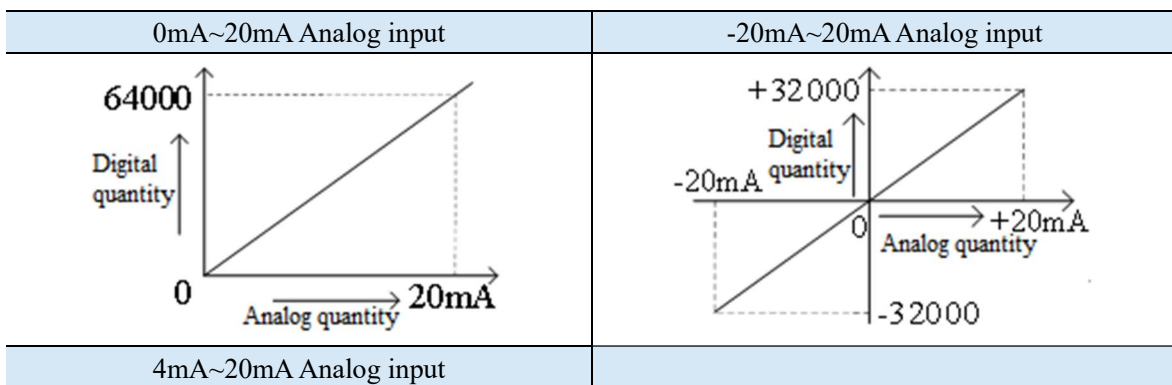

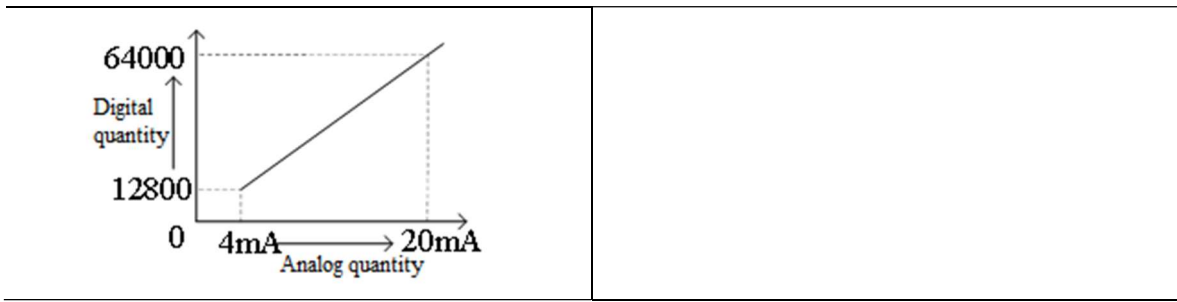

5.2.5 Terminal definition&Wiring

5.2.5.1 Appearance dimension diagram

(Unit: mm)

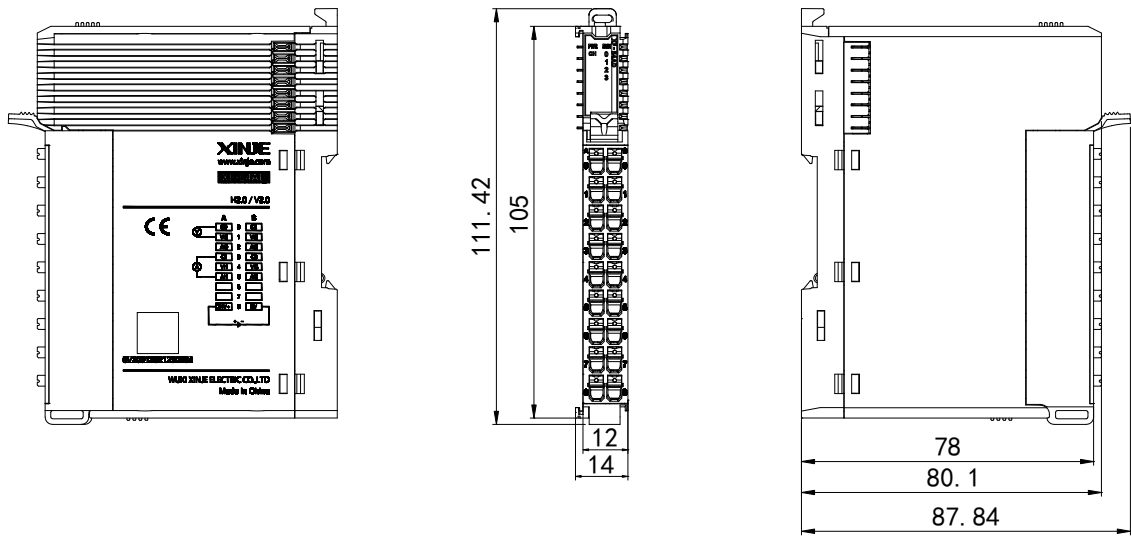

5.2.5.2 Terminal definition&Wiring

■ Terminal definition

XF-E4AD				
Meaning	A-column terminal	Terminal layout	B-column terminal	Meaning
CH0- Input ground	0		0	CH2- Input ground
CH0-AD analog voltage input terminal	1		1	CH2-AD analog voltage input terminal
CH0-AD analog current input terminal	2		2	CH2-AD analog current input terminal
CH1- Input ground	3		3	CH3- Input ground
CH1-AD analog voltage input terminal	4		4	CH3-AD analog voltage input terminal
CH1-AD analog current input terminal	5		5	CH3-AD analog current input terminal
Empty	6		6	Empty
Empty	7		7	Empty

XF-E4AD				
Meaning	A-column terminal	Terminal layout	B-column terminal	Meaning
External 24V power supply for module positive	8		8	External power supply to the module 24V power supply negative

■ External wiring

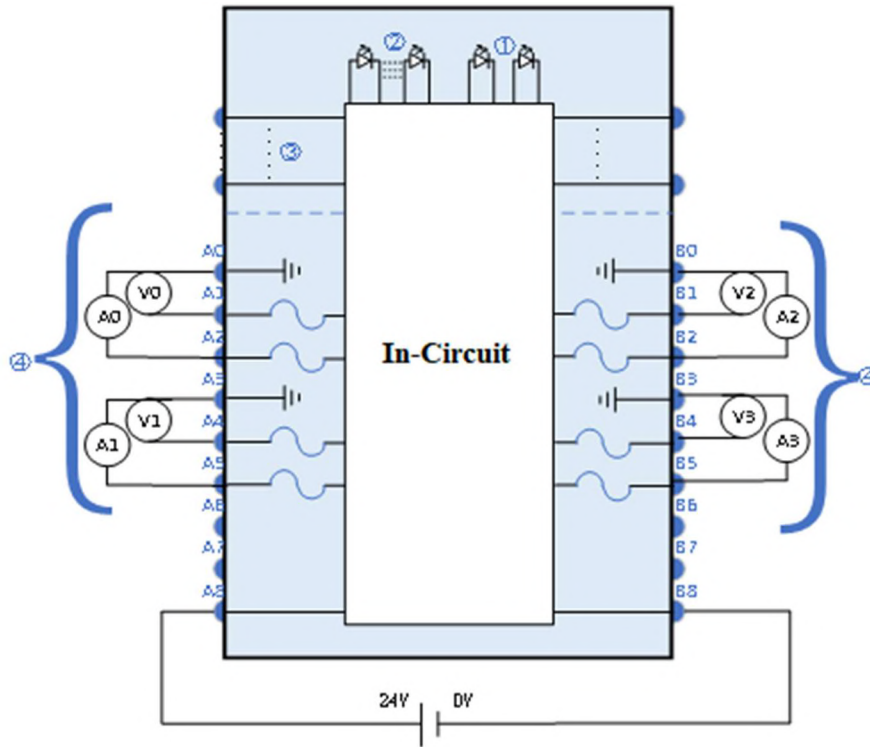

- ① System indicator ② Channel indicator light ③ Backplane bus ④ Input channels & wiring

5.2.5.3 Installation method

1) Installation requirements

The module is installed using DIN rails, which must comply with the IEC 60715 standard (35mm wide, 1mm thick). The dimension information is shown in the following figure, and the unit is (mm).

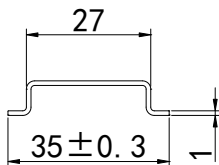

Note

When the module is installed on a non recommended DIN rail, the DIN rail latch may not lock properly.

2) Installation steps

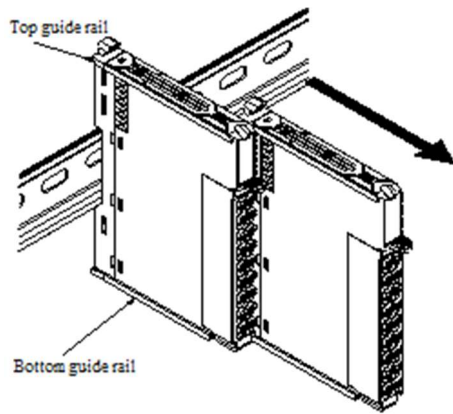

1. The assembly between IO modules is installed by sliding through the top and bottom guide rails of the modules, as shown in the left figure:

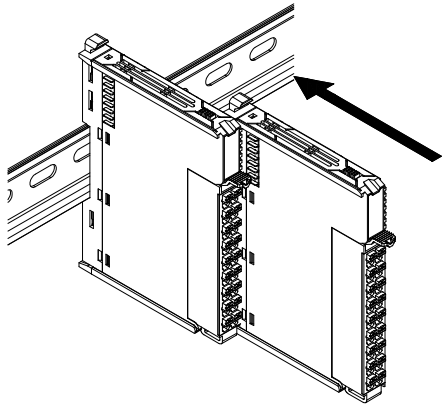

2. The module is installed on the guide rail. When installing, align the module with the DIN guide rail and press the module in the direction indicated by the arrow. After installation, there is a clear sound of engagement, as shown in the left figure:

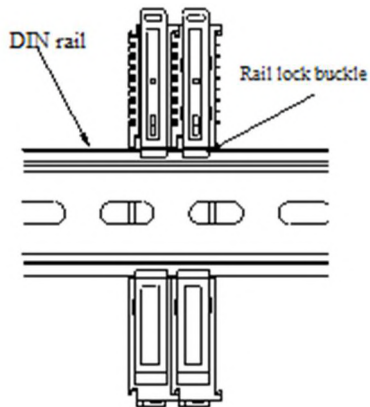

Explanation: After the module installation is completed, the locking buckle will automatically move downwards for locking, if the latch does not move downwards, press down on the top of the latch, ensure proper installation.

3) Disassembly steps

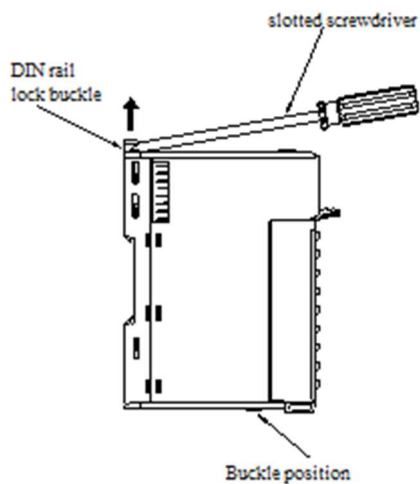

1. Use a flat screwdriver or similar tool to pry the rail lock upwards, as shown in the left figure:

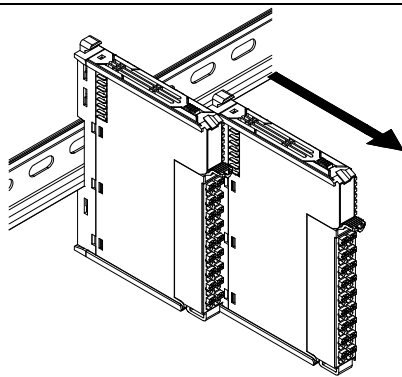

2. Pull the module straight forward at the buckle position (raised part), and then press down on the top of the latch, as shown in the left figure:

5.2.5.4 Installation environment

This product can be installed in four positions (i.e. installation direction): horizontal, vertical, top of cabinet, and bottom of cabinet. It is recommended to install in the horizontal direction, and the heat dissipation design is through natural convection. To ensure normal ventilation and heat dissipation and reserve sufficient wiring space, the minimum gap must be left around this product, as shown in the following figure:

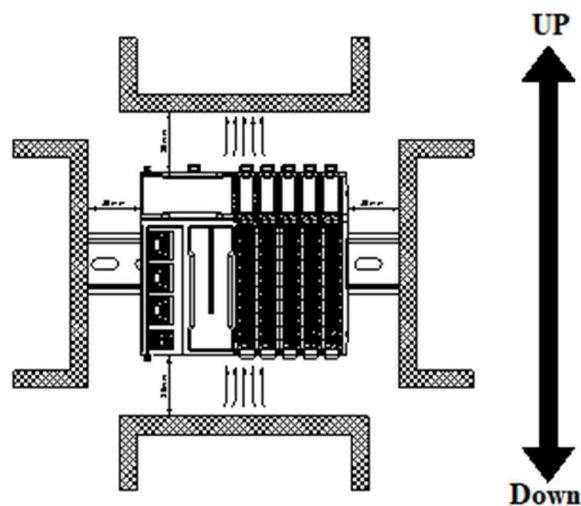

If there are high-temperature heat source equipment (heaters, transformers, large resistors, etc.) around this product, leave at least 100mm gap between the equipment and the high-temperature heat source.

5.2.5.5 Equipment wiring

When wiring the module, its terminal must meet the following requirements:

Adaptor diameter	
National standard/mm ²	American standard/AWG
0.3	22
0.5	20
0.75	18
1.0	18
1.5	16

If using other tube type wire ears, please crimp them to the twisted wire. The shape and size requirements are shown in the following figure:

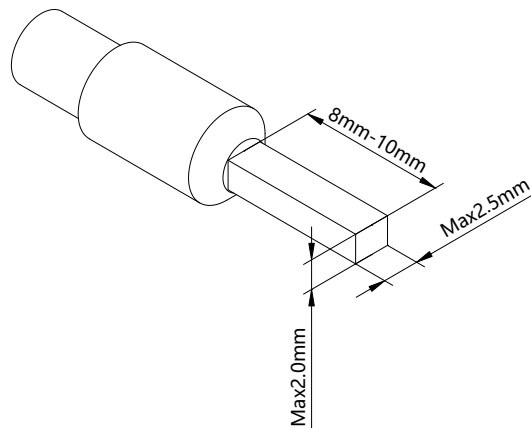

5.2.6 Usage of XF-E4AD and LFC3-AP

5.2.6.1 Process data mapping (PDO)

Name	Type	Explanation
XF_E4AD	Stuct	4-channel input module
CH0	DINT	Channel 0 input value
CH1	DINT	Channel 1 input value
CH2	DINT	Channel 2 input value
CH3	DINT	Channel 3 input value
ErrCode_module	WORD	Module level error codes
ErrCode_CH	DWORD	Channel level error code

■ Error code parameters

Module level error codes (ErrCode_module)		
Bit position	Meaning	Error level
0	The 24V input power supply of the module is abnormal	Important

Module level error codes (ErrCode_module)		
Bit position	Meaning	Error level
2	Internal module error occurred and cannot be fixed by the user layer	Important
3	Version mismatch	Important
4	ADC/DAC read/write failure	Important

Channel level error code (ErrCode_CH)		
Bit position	Meaning	Error level
0	Channel 0 upper limit overflow	General
1	Channel 0 lower limit overflow	General
2	Channel 0 disconnected	Important
3	Reserve	-
4	Channel 1 upper limit overflow	General
5	Channel 1 lower limit overflow	General
6	Channel 1 disconnected	Important
7	Reserve	-
8	Channel 2 upper limit overflow	General
9	Channel 2 lower limit overflow	General
10	Channel 2 disconnected	Important
11	Reserve	-
12	Channel 3 upper limit overflow	General
13	Channel 3 lower limit overflow	General
14	Channel 3 disconnected	Important

5.2.6.2 Module configuration parameters (SDO)

Parameter	Type	Channel	Note
Power detection	Enumeration of BYTE	--	0: Close 1: Open
Channel enable/disable		Channel 0-4	0: Close 1: Open
Enable/disable wire breakage detection			0: Close 1: Open
Range selection	0: 0~10V(Default) 4: 1~5V 1: 0~5V 5: 0~20mA 2: -10~10V 6: 4~20mA 3: -5~5V 7: -20~20mA		
Filtering method	0: First order filtering 1: Time average		2: Average number of times 3: Moving average
Filtering parameter	INT		Time average (2-100ms) default value 2 Average frequency (4-500) default value 4 Moving average (2-500) default value 2 First order delay filtering (0-254) defaults

Parameter	Type	Channel	Note
			to 0 (no filtering)
Calibration enable/disable	Enumeration of BYIE		0: Close 1: Open
Calibration 1 analog quantity	INT		Voltage input 0~10V: Analog range: 0-10000mV Digital range: 0-64000 0~5V: Analog range:0-5000mV Digital range: 0-64000 -10~10V: Analog range: -10000-10000mV Digital range: -32000-32000 -5~5V: Analog range: -5000-5000mV Digital range: -32000-32000 1~5V: Analog range: 1000mV-5000mV Digital range: 12800-64000 Current input 0~20mA: Analog range: 0-20000uA Digital range: 0-64000 4~20mA: Analog range: 4000-20000uA Digital range: 12800-64000 -20~20mA: Analog range: -20000-20000uA Digital range: -32000-32000
Calibration 1 digital quantity	DINT		
Calibration 2 analog quantity	INT		
Calibration 2 digital quantity	DINT		
Enable/disable unit display conversion	Enumeration of BYTE		
Unit display conversion limit	DINT		
Unit Display Conversion Lower Limit			
Enable/disable upper and lower limit overflow settings	Enumeration of BYTE		
Upper limit overflow analog quantity	INT		
Upper limit overflow	DINT		

Parameter	Type	Channel	Note
output digital quantity			0~10V:
Lower limit overflow analog quantity	INT		Analog range: 0-10000mV Digital range: 0-64000
Lower limit overflow output digital quantity	DINT		0~5V: Analog range: 0-5000mV Digital range: 0-64000
Lower limit overflow output digital quantity	DINT		-10~10V: Analog range: -10000-10000mV Digital range: -32000-32000
Lower limit overflow output digital quantity	DINT		-5~5V: Analog range: -5000-5000mV Digital range: -32000-32000
Lower limit overflow output digital quantity	DINT		1~5V: Analog range: 1000mV-5000mV Digital range: 12800-64000
			Current input
			0~20mA : Analog range: 0-20000uA Digital range: 0-64000
			4~20mA : Analog range: 4000-20000uA Digital range: 12800-64000
			-20~20mA: Analog range: -20000-20000uA Digital range: -32000-32000

■ Module power supply detection

- Check if the external 24V power supply of the module is normal.
- ◆ Normal: The module is running normally.
- ◆ Exception: The module channel cannot be used but can be configured, configured, and scanned normally.
- Can set parameters: enable or disable (default is disabled).

Index:SubIndex	Name	Flag	Value	Communication error message
#x8021:00	Module	rw	>1<	
01	Power Detection	rw		Communication not established
#x8022:00	Channel 0	rw	>18<	
15	Channel enable/disable	rw		Communication not established
16	Enable/disable wire breakage...	rw		Communication not established
17	Range selection	rw		Communication not established
18	Filtering method	rw		Communication not established
19	filtering parameter	rw		Communication not established
1B	Calibration enable/disable	rw		Communication not established
1C	Calibration 1 Analog Quantity	rw		Communication not established
1E	Calibration 1 Digital Quantity	rw		Communication not established
22	Calibration 2 Analog Quantity	rw		Communication not established
24	Calibration 2 Digital Quantity	rw		Communication not established
28	Enable/disable unit display ...	rw		Communication not established
29	Unit display conversion limit	rw		Communication not established

■ Channel enable/disable

Enable or disable AD sampling channels to save module sampling time.

Index:SubIndex	Name	Flag	Value	Communication error message
#x8021:00	Module	rw	>1<	
-01	Power Detection	rw		Communication not established
#x8022:00	Channel 0	rw	>18<	
-15	Channel enable/disable	rw		Communication not established
-16	Enable/disable wire breakage...	rw		Communication not established
-17	Range selection	rw		Communication not established
-18	Filtering method	rw		Communication not established
-19	filtering parameter	rw		Communication not established
-1B	Calibration enable/disable	rw		Communication not established
-1C	Calibration 1 Analog Quantity	rw		Communication not established
-1E	Calibration 1 Digital Quantity	rw		Communication not established
-22	Calibration 2 Analog Quantity	rw		Communication not established
-24	Calibration 2 Digital Quantity	rw		Communication not established
-28	Enable/disable unit display ...	rw		Communication not established
-29	Unit display conversion limit	rw		Communication not established
-2D	Unit Display Conversion Lowe...	rw		Communication not established
-31	Enable/disable upper and low...	rw		Communication not established
-32	Upper limit overflow analog ...	rw		Communication not established
-34	Upper limit overflow output ...	rw		Communication not established
-38	Lower limit overflow analog ...	rw		Communication not established
-3A	Lower limit overflow output ...	rw		Communication not established

Settable parameters	Enable/disable (in disable mode, subsequent software functions for the corresponding channel cannot be set)
Default parameters	Enable
Note	The conversion time for each channel is 60us, and the total time is equal to the on/off conversion speed multiplied by the number of enabled channels. If this channel is not used, it can be set to "disable" to reduce the total conversion time of the module

- Wire breakage detection
- Detect abnormal disconnection of AD input channel and configure alarm logs. If there is no current flowing through the module or the current flowing is too low (the measurement range is 4-20 mA or 1-5V), the corresponding alarm log will be triggered, which can activate both circuit breaker detection and underflow simultaneously.
- Can set parameters: enable or disable (default is disabled).

This function is only supported when the "measurement range" is set to "4mA~20mA" and "1V~5V".

Index:Sub...	Name	Flag	Value	Communication error message
#x8022:00	Channel 0	rw	>18<	
-15	Channel enable/disable	rw		Communication not established
-16	Enable/disable wire breakage detection	rw		Communication not established
-17	Range selection	rw		Communication not established
-18	Filtering method	rw		Communication not established
-19	filtering parameter	rw		Communication not established
-1B	Calibration enable/disable	rw		Communication not established

- Sampling type/range

You can choose different types and ranges of sampling analog signals.

Index:Sub...	Name	Flag	Value	Communication error message
#x8022:00	Channel 0	rw	>18<	
-15	Channel enable/disable	rw		Communication not established
-16	Enable/disable wire breakage detection	rw		Communication not established
-17	Range selection	rw		Communication not established
-18	Filtering method	rw		Communication not established
-19	filtering parameter	rw		Communication not established
-1B	Calibration enable/disable	rw		Communication not established
-1C	Calibration 1 Analog Quantity	rw		Communication not established
-1E	Calibration 1 Digital Quantity	rw		Communication not established
-22	Calibration 2 Analog Quantity	rw		Communication not established
-24	Calibration 2 Digital Quantity	rw		Communication not established
-28	Enable/disable unit display conversion	rw		Communication not established
-29	Unit display conversion limit	rw		Communication not established
-2D	Unit Display Conversion Lower Limit	rw		Communication not established
-31	Enable/disable upper and lower limit overflow settings	rw		Communication not established
-32	Upper limit overflow analog quantity	rw		Communication not established
-34	Upper limit overflow output digital quantity	rw		Communication not established
-38	Lower limit overflow analog quantity	rw		Communication not established
-3A	Lower limit overflow output digital quantity	rw		Communication not established

Settable parameters	Configure the corresponding index objects in COE-Online, startup parameters, or SDO read and write instructions: voltage, current
Default parameters	0V~10V
Voltage measurement range	0V~5V, 0V~10V, -5V~5V, -10V~10V, 1V~5V Default: 0V~10V
Current measuring range	0mA~20mA, 4mA~20mA, -20mA~20mA

■ Channel filtering parameters

● First order filtering

The first-order low-pass filtering method uses the weighting of the current sampling value and the output value of the previous filtering to obtain the effective filtering value. The filtering coefficient is set by the user to 0~254. The smaller the value, the more stable the data will be, but it may cause data lag; Therefore, when set to 1, the filtering effect is strongest and the data is most stable. When set to 254, the filtering effect is weakest. The default is 0 (not filtered).

● Average filtering

Time average	Functional actions	Perform A/D conversion according to the set time, and average the total value after removing the maximum and minimum values. The average processed value is stored in the corresponding output buffer memory. The number of processing times within the set time varies depending on the number of channels allowed for A/D conversion.
	Set range	2~100ms (Default value 2)
Frequency average	Functional actions	Perform A/D conversion according to the set number of times, and average the total value after removing the maximum and minimum values. The average processed value is stored in the corresponding channel variable. The time it takes for the average of the number of times to be stored in the corresponding channel variable varies depending on the number of channels allowed for A/D conversion.
	Set range	4~500 (Default value 4)

Move average times	Functional actions	After averaging the specified number of digital output values obtained in each sampling cycle, store them in the corresponding output register/variable. Due to moving average processing in each sampling process, the latest digital output values can be obtained.
	Set range	2~500 (Default value 2)

- Settable parameters
- ◆ Filtering mode (configuring corresponding index objects in COE-Online, startup parameters, or SDO read and write instructions): "first order filtering", "time average filtering", "frequency average filtering", and "moving average filtering" (default: first order filtering).
- ◆ Filter parameters (corresponding index objects configured in COE-Online, startup parameters, or SDO read and write instructions): in the "first-order filtering" mode, you can set: 0~254 (default value: 0), in the "time average filtering" mode, you can set: 2ms~100ms(default value: 2), in the "average filtering times" mode, it can be set to 4~500 (default value: 4), in the "moving average filtering" mode, it can be set to 2~500 (default value: 2).

Launch parameters IO Mapping COE-Online

Advanced options

Index:SubI...	Name	Flag	Value	Communication error message
#x8021:00	Module	rw	>1<	
#x8022:00	Channel 0	rw	>18<	
-15	Channel enable/disable	rw		Communication not established
-16	Enable/disable wire breakage detection	rw		Communication not established
-17	Range selection	rw		Communication not established
-18	Filtering method	rw		Communication not established
-19	filtering parameter	rw		Communication not established
-1B	Calibration enable/disable	rw		Communication not established
-1C	Calibration 1 Analog Quantity	rw		Communication not established
-1E	Calibration 1 Digital Quantity	rw		Communication not established
-22	Calibration 2 Analog Quantity	rw		Communication not established

■ Calibration function

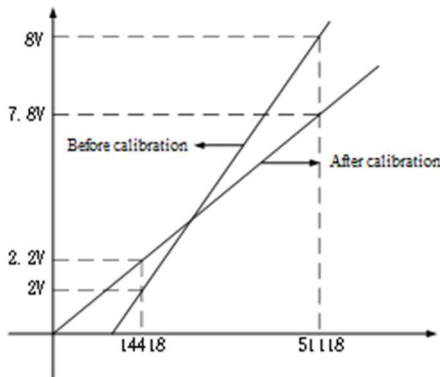

Due to the possibility of drift between the digital signals obtained from AD acquisition and conversion and the analog signals received after the product has been used for a period of time at the factory, customers can calibrate by setting the AD calibration function, immediately reflect to the scaling value (numerical operation value), you can easily complete the calibration during system startup on your own.

Index:SubIndex	Name	Flag	Value	Communication error message
#x8021:00	Module	rw	>1<	
#x8022:00	Channel 0	rw	>18<	
-15	Channel enable/disable	rw		Communication not established
-16	Enable/disable wire breakage detection	rw		Communication not established
-17	Range selection	rw		Communication not established
-18	Filtering method	rw		Communication not established
-19	filtering parameter	rw		Communication not established
-1B	Calibration enable/disable	rw		Communication not established
-1C	Calibration 1 Analog Quantity	rw		Communication not established
-1E	Calibration 1 Digital Quantity	rw		Communication not established
-22	Calibration 2 Analog Quantity	rw		Communication not established
-24	Calibration 2 Digital Quantity	rw		Communication not established
-28	Enable/disable unit display conversion	rw		Communication not established
-29	Unit display conversion limit	rw		Communication not established
-2D	Unit Display Conversion Lower Limit	rw		Communication not established
-31	Enable/disable upper and lower limit o...	rw		Communication not established
-32	Upper limit overflow analog quantity	rw		Communication not established
-34	Upper limit overflow output digital qu...	rw		Communication not established
-38	Lower limit overflow analog quantity	rw		Communication not established
-3A	Lower limit overflow output digital qu...	rw		Communication not established

■ Unit display conversion

This function can directly display the output analog data as the actual output unit required by the customer.

Due to the fact that customers use analog expansion module DA to output analog signals that correspond to the outputs of some instruments or sensors. For example, controlling the frequency output range of a frequency converter to be 0-50Hz, and controlling the output frequency of the frequency converter to control the analog signal to be 4-20mA, the existing DA module will output 4-20mA analog signal to the analog acquisition terminal of the frequency converter. Customers need to convert the digital signal from 0 to 65535 to 0 to 50Hz for the actual output frequency of the frequency converter. It is possible to automatically convert the analog output of module DA into the actual output frequency value of the frequency converter by setting the conversion value range.

Index:SubIndex	Name	Flag	Value	Communication error message
#x8021:00	Module	rw	>1<	
#x8022:00	Channel 0	rw	>18<	
-15	Channel enable/disable	rw		Communication not established
-16	Enable/disable wire breakage detection	rw		Communication not established
-17	Range selection	rw		Communication not established
-18	Filtering method	rw		Communication not established
-19	filtering parameter	rw		Communication not established
-1B	Calibration enable/disable	rw		Communication not established
-1C	Calibration 1 Analog Quantity	rw		Communication not established
-1E	Calibration 1 Digital Quantity	rw		Communication not established
-22	Calibration 2 Analog Quantity	rw		Communication not established
-24	Calibration 2 Digital Quantity	rw		Communication not established
-28	Enable/disable unit display conversion	rw		Communication not established
-29	Unit display conversion limit	rw		Communication not established
-2D	Unit Display Conversion Lower Limit	rw		Communication not established
-31	Enable/disable upper and lower limit o...	rw		Communication not established
-32	Upper limit overflow analog quantity	rw		Communication not established
-34	Upper limit overflow output digital qu...	rw		Communication not established
-38	Lower limit overflow analog quantity	rw		Communication not established
-3A	Lower limit overflow output digital qu...	rw		Communication not established

■ Up and down overflow settings

When the AD channel sampling is greater than the Upper limit/Lower limit set value, an alarm log is triggered and the set value is output.

Index:SubIndex	Name	Flag	Value	Communication error message
#x8021:00	Module	rw	>1<	
#x8022:00	Channel 0	rw	>18<	
-15	Channel enable/disable	rw		Communication not established
-16	Enable/disable wire breakage detection	rw		Communication not established
-17	Range selection	rw		Communication not established
-18	Filtering method	rw		Communication not established
-19	filtering parameter	rw		Communication not established
-1B	Calibration enable/disable	rw		Communication not established
-1C	Calibration 1 Analog Quantity	rw		Communication not established
-1E	Calibration 1 Digital Quantity	rw		Communication not established
-22	Calibration 2 Analog Quantity	rw		Communication not established
-24	Calibration 2 Digital Quantity	rw		Communication not established
-28	Enable/disable unit display conversion	rw		Communication not established
-29	Unit display conversion limit	rw		Communication not established
-2D	Unit Display Conversion Lower Limit	rw		Communication not established
-31	Enable/disable upper and lower limit overflow settings	rw		Communication not established
-32	Upper limit overflow analog quantity	rw		Communication not established
-34	Upper limit overflow output digital quantity	rw		Communication not established
-38	Lower limit overflow analog quantity	rw		Communication not established
-3A	Lower limit overflow output digital quantity	rw		Communication not established

5.2.7 Usage of XF-E4AD and LFP3-AP

5.2.7.1 Process data mapping

In the device view, the mapping address of module process data can be viewed, and the case mapping address is IB68-IB89.

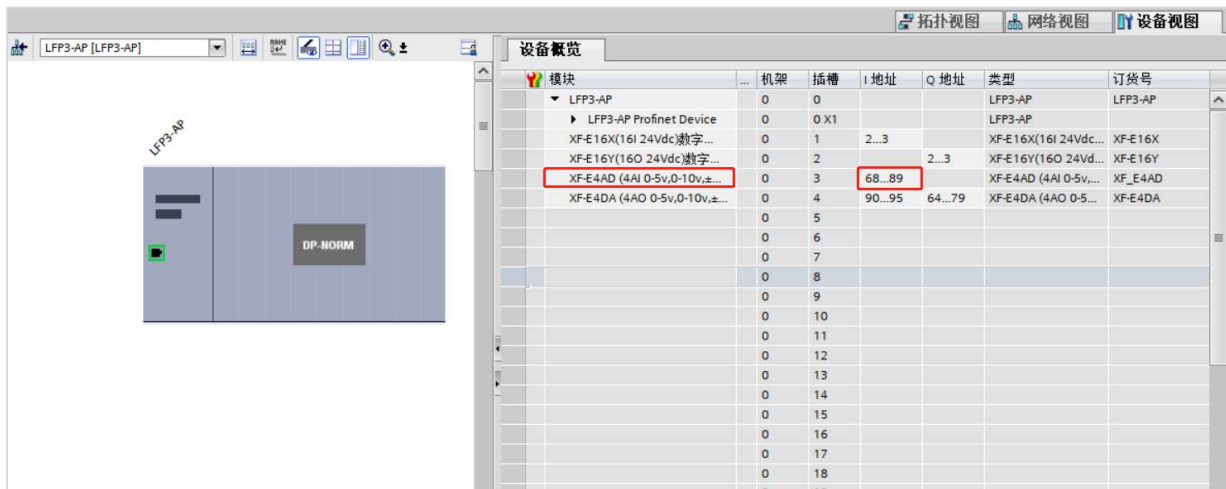

Name	Type	Explanation
XF_E4AD	Stuct	4-channel input module
ID68(IB68~IB71)	DINT	Channel 0 input value
ID72(IB72~IB75)	DINT	Channel 1 input value
ID76(IB76~IB79)	DINT	Channel 2 input value
ID80(IB80~IB83)	DINT	Channel 3 input value
ID84(IB84~IB85)	WORD	Module level error codes
ID86(IB86~IB89)	DWORD	Channel level error code

■ Error code parameters

Module level error codes (ErrCode_module)		
Bit position	Meaning	Error level
0	The 24V input power supply of the module is abnormal	Important
2	Internal module error occurred and cannot be fixed by the user layer	Important
3	Version mismatch	Important
4	ADC/DAC read/write failure	Important

Channel level error code (ErrCode_CH)		
Bit position	Meaning	Error level
0	Channel 0 upper limit overflow	General
1	Channel 0 lower limit overflow	General
2	Channel 0 disconnected	Important
3	Reserve	-
4	Channel 1 upper limit overflow	General
5	Channel 1 lower limit overflow	General
6	Channel 1 disconnected	Important
7	Reserve	-
8	Channel 2 upper limit overflow	General
9	Channel 2 lower limit overflow	General
10	Channel 2 disconnected	Important
11	Reserve	-
12	Channel 3 upper limit overflow	General
13	Channel 3 lower limit overflow	General
14	Channel 3 disconnected	Important

5.2.7.2 Module configuration parameters

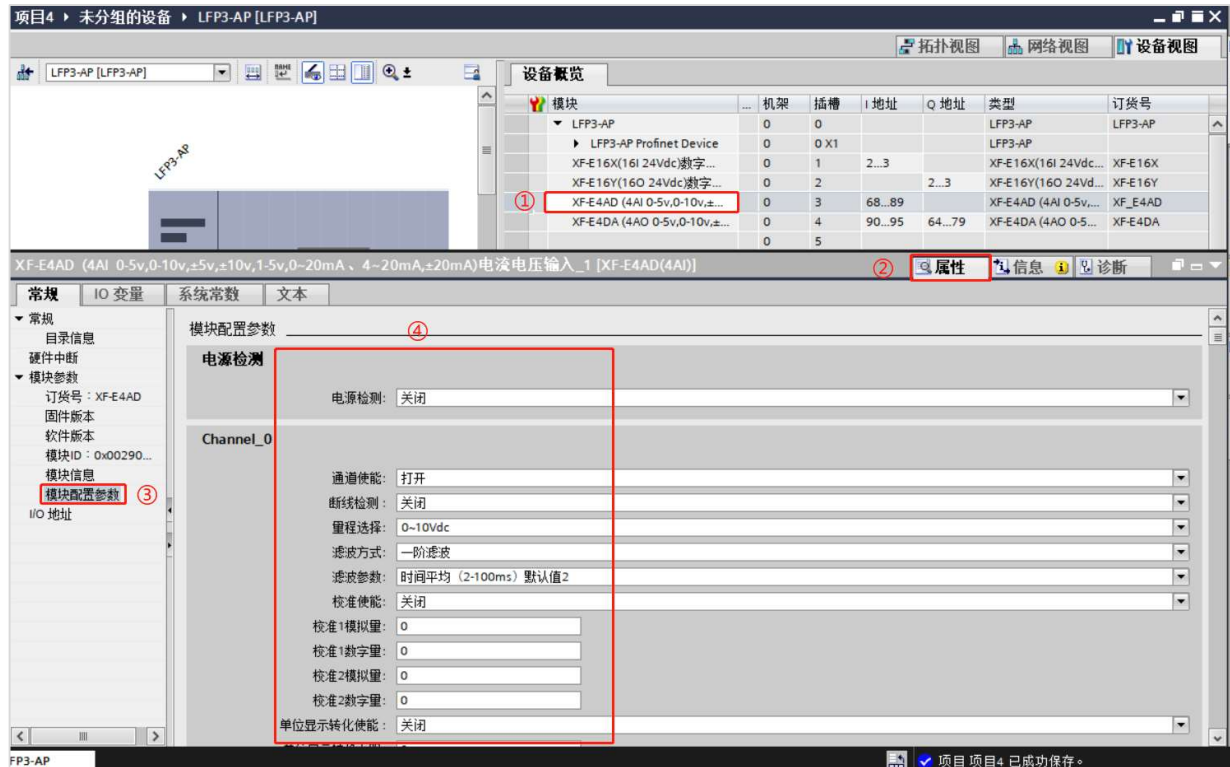

- Module power supply detection
 - Check if the external 24V power supply of the module is normal:
 - ◆ Normal: The module is running normally.
 - ◆ Exception: The module channel cannot be used but can be configured, configured, and scanned normally.
 - Parameters can be set: enable or disable (default is disabled).
- Channel enable/disable

Enable or disable AD sampling channels to save module sampling time.

Settable parameters	Enable/disable (in disable mode, subsequent software functions for the corresponding channel cannot be set)
Default parameters	Enable
Note	The conversion time for each channel is 60us, total time=on/off conversion speed * number of enabled channels, if this channel is not used, it can be set to "disable" to reduce the total conversion time of the module

- Wire breakage detection
 - Detect abnormal disconnection of AD input channel and configure alarm logs. If there is no current flowing through the module or the current flowing is too low (the measurement range is 4-20 mA or 1-5V), the corresponding alarm log will be triggered, which can activate both circuit breaker detection and underflow simultaneously.
 - Parameters can be set: enable or disable (default is disabled).



This function is only supported when the "measurement range" is set to "4mA~20mA" and "1V~5V".

■ Sampling type/range

Can choose different types and ranges of sampling analog signals.

Settable parameters	The following table pulling method reflects the adjustable parameters: voltage, current
Default parameters	0V~10V
Voltage measurement range	0V~5V, 0V~10V, -5V~5V, -10V~10V, 1V~5V Default: 0V~10V
Current measuring range	0mA~20mA, 4mA~20mA, -20mA~20mA

■ Channel filtering parameters

● First order filtering

The first-order low-pass filtering method uses the weighting of the current sampling value and the output value of the previous filtering to obtain the effective filtering value. The filtering coefficient is set by the user to 0~254. The smaller the value, the more stable the data will be, but it may cause data lag. Therefore, when set to 1, the filtering effect is strongest and the data is most stable. When set to 254, the filtering effect is weakest. The default is 0 (not filtered).

● Average filter

Time average	Functional actions	Perform A/D conversion according to the set time, and average the total value after removing the maximum and minimum values. The average processed value is stored in the corresponding output buffer memory. The number of processing times within the set time varies depending on the number of channels allowed for A/D conversion.
	Set range	2~100ms (Default value 2)
Frequency average	Functional actions	Perform A/D conversion according to the set number of times, and average the total value after removing the maximum and minimum values. The average processed value is stored in the corresponding channel variable. The time it takes for the average of the number of times to be stored in the corresponding channel variable varies depending on the number of channels allowed for A/D conversion.
	Set range	4~500 (Default value 4)
Move average times	Functional actions	After averaging the specified number of digital output values obtained in each sampling cycle, store them in the corresponding output register/variable. Due to moving average processing in each sampling process, the latest digital output values can be obtained.
	Set range	2~500 (Default value 2)

● Settable parameters

- ◆ Filter mode (selected from dropdown menu): " first order filtering", "time average filtering", "frequency average filtering", and "moving average filtering" (default: first order filtering).
- ◆ Filter parameters (selected using input box): in the "first-order filtering" mode, it can be set to 0~254 (default value: 0), in the "Time Average Filtering" mode, it can be set to 2ms~100ms (default value: 2), in the "average filtering" mode, you can set: 4~500 (default value: 4), in the "moving average filtering" mode, it can be set to 2~500 (default value: 2).

■ Calibration function

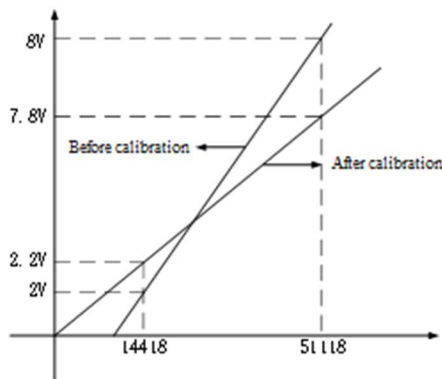

Due to the possibility of drift between the digital signals obtained from AD acquisition and conversion and the analog signals received after the product has been used for a period of time at the factory, customers can calibrate by setting the AD calibration function, immediately reflect to the scaling value (numerical operation value), you can easily complete the calibration during system startup on your own.

■ Unit display conversion

This function can directly display the output analog data as the actual output unit required by the customer.

Due to the fact that the customer's use of analog expansion module DA outputs mostly analog signals corresponding to the outputs of some instruments or sensors. For example, controlling the frequency output range of a frequency converter to be 0~50Hz, the frequency control analog signal of the frequency converter is 4~20mA. The existing DA module will output the 4~20mA analog signal to the analog acquisition terminal of the frequency converter, and the customer needs to convert the digital signal from 0~65535 to 0~50Hz for the actual output frequency of the frequency converter. It is possible to automatically convert the analog output of module DA into the actual output frequency value of the frequency converter by setting the conversion value range.

■ Up and down overflow setting

Trigger an alarm log and output the set value when the AD channel sampling is greater than the Upper limit/Lower limit setting value.

5.3 Analog output unit XF-E4DA

5.3.1 Overview

XF-E4DA series analog output expansion module, which has 4 channels of analog input, supporting current and voltage inputs, adapt to XF, XSF series CPU unit products and XF series communication coupler units.

- 4-channel analog output.
- Channel conversion speed 60us/channel.
- Maximum error of 0.2%.
- Voltage and current input.
- Designed with a width of 12mm.

■ Module version

Hardware version	Firmware version	Function
H2.0	V2.0	Basic functions for the first official production

5.3.2 Module view

1) Description of each section

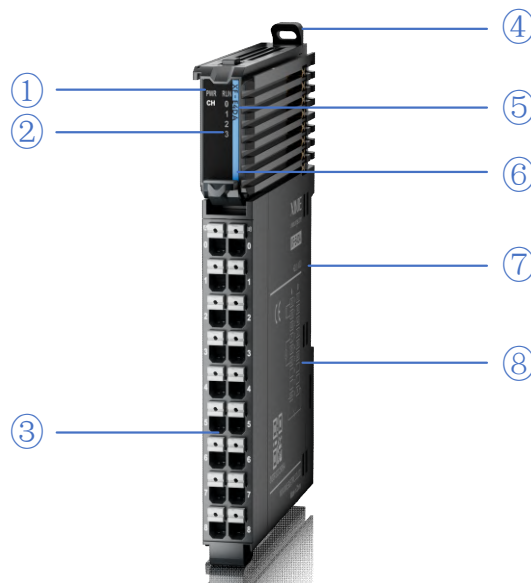

No.	Name	No.	Name
①	System LED indicator lights	②	Channel LED indicator light
③	Detachable terminal block	④	Snap
⑤	Model indication	⑥	Color identification indicating module type
⑦	Module hardware and firmware versions	⑧	Wiring diagram

2) System indicator

System indicator	Explanation	
PWR (Green)	Extinguish	Module not powered on
	Light	All external power supplies of the module are normal (backplane bus power supply&external input 24V)
	Flash1Hz* ¹	Abnormal power supply in the module and inability to operate normally
RUN (Green)	Light	The module is running normally
	Flash1Hz* ¹	General errors in module logs
	Extinguish	Important errors in module logs
	Flash10Hz* ²	Module establishing communication
	Double flashing* ³	Module firmware update

- *1: A square wave with a duty cycle of 50% and a frequency of 1Hz.
- *2: A square wave with a duty cycle of 50% and a frequency of 10Hz.
- *3: As shown in the following figure:

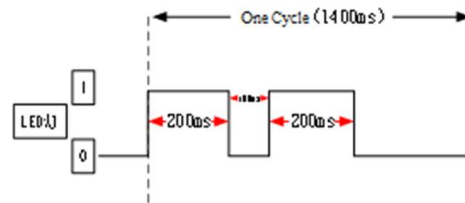

3) Channel indicator light

Model	Channel indicator light		
XF-E4DA	CH0~CH3	Light (Green)	Channel enabled and configured correctly
		Extinguish	Mute channel

4) Color identification

No.	Colour	Module type
1	White	Digital input
2	Grey	Digital output&digital mixing module
3	Light blue	Analog input
4	Deep blue	Analog output

5.3.3 General specification

General specification		
Project	Specifications	
Operating temperature	Maximum temperature	55°C
	Minimum temperature	-20°C
Transportation/Storage Temperature	Maximum temperature	70°C
	Minimum temperature	-40°C

General specification		
Project		Specifications
Environmental humidity (including operation/storage)	Upper limit	95%
	Lower limit	10%
IP code		IP20
Anti vibration		Compliant with IEC61131-2 Under intermittent vibration (frequency 5-9Hz, constant amplitude 3.5mm peak displacement) and (frequency 9-150Hz, constant acceleration 1.0g peak acceleration) Under continuous intermittent vibration (frequency 5-9Hz half amplitude 1.75mm displacement) and (frequency 9-150Hz constant acceleration 0.5g constant frame amplitude) Scan 10 times in X, Y, and Z directions
Impact resistance		Complies with IEC61131-2 standard The impact strength is 15G (peak) and the duration is 11ms. It is applied to three mutually perpendicular axes, and each axis is impacted 3 times (a total of 18 impacts)
Using environment		Non corrosive gas
Using altitude		0-2000 m
Overvoltage level		II: Compliant with IEC61131-2
Pollution level		2: Compliant with IEC61131-2
Anti interference EMC		Compliant with IEC 61131-2 IEC61000-6-4 Type B
Related certifications		CE

5.3.4 Technical specifications

5.3.4.1 Module performance

Project		Specifications
Input channel		4
Analog input range (rated)	Voltage output range	0V~5V (0~64000) 0V~10V (0~64000) -5V~5V (-32000~32000) -10V~10V (-32000~32000) 1v~5v (12800~64000)
	Current output range	0mA~20mA (0~64000) 4mA~20mA (12800~64000)
Maximum input range	Voltage input	DC±15V
	Current input	-40~40mA
Conversion speed		60us/CH
Resolution ratio		1/64000 (16Bit)
Module power supply	Rated input	DC24V±10%, 150mA
	Protect	Reverse polarity protection
Error	Room temperature 25°C±5°C	±0.1% (25±5 °C)
	Full temperature end -20~55°C	±0.2%
Isolated		Channel non isolated, power isolated
Module power consumption		0.8W (backplane bus)+0.8W (external input)

5.3.4.2 Analog-to-digital conversion diagram

■ Voltage

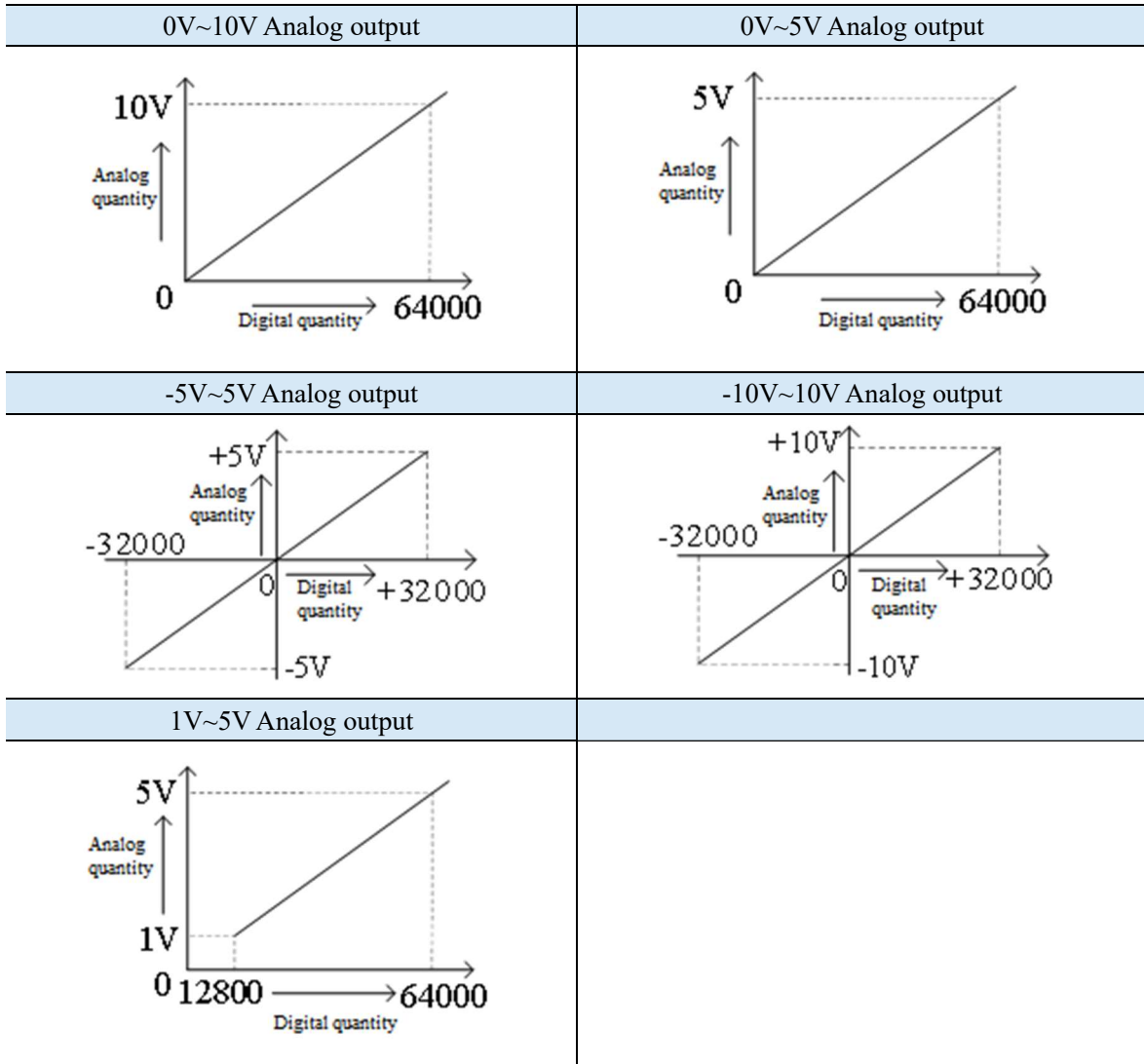

■ Current

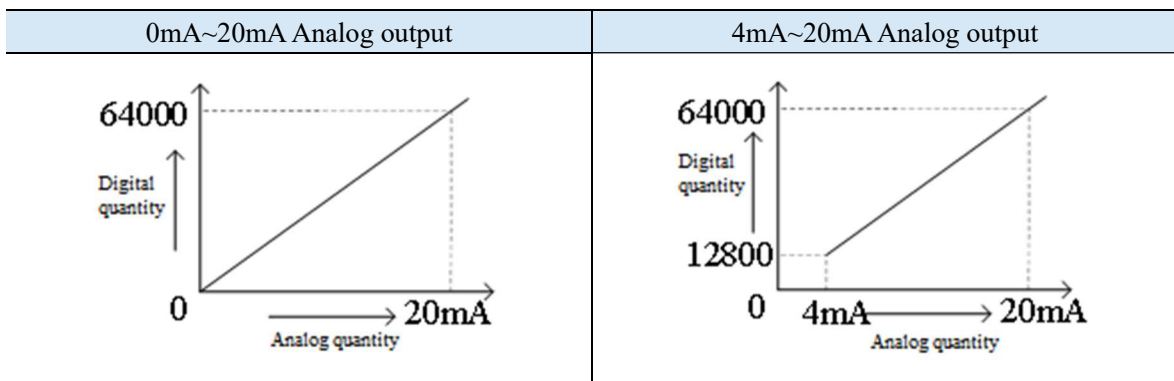

5.3.5 Terminal definition&Wiring

5.3.5.1 Appearance dimension diagram

(Unit: mm)

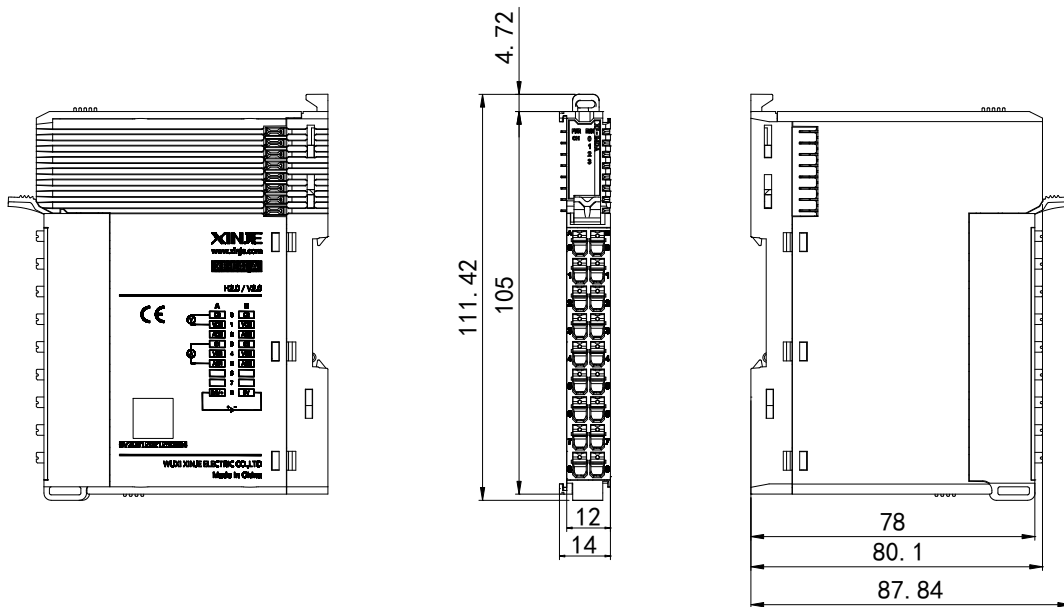

5.3.5.2 Terminal definition&Wiring

■ Terminal definition

XF-E4DA				
Meaning	A-column terminal	Terminal layout	B-column terminal	Meaning
CH0- output ground	0		0	CH2- output ground
CH0-DA analog voltage output terminal	1		1	CH2-DA analog voltage output terminal
CH0-DA analog current output terminal	2		2	CH2-DA analog current output terminal
CH1- output ground	3		3	CH3- output ground
CH1-DA analog voltage output terminal	4		4	CH3-DA analog voltage output terminal
CH1-DA analog current output terminal	5		5	CH3-DA analog current output terminal
Empty	6		6	Empty
Empty	7		7	Empty
External 24V power supply for module positive	8		8	External power supply to the module 24V power supply negative

■ External wiring

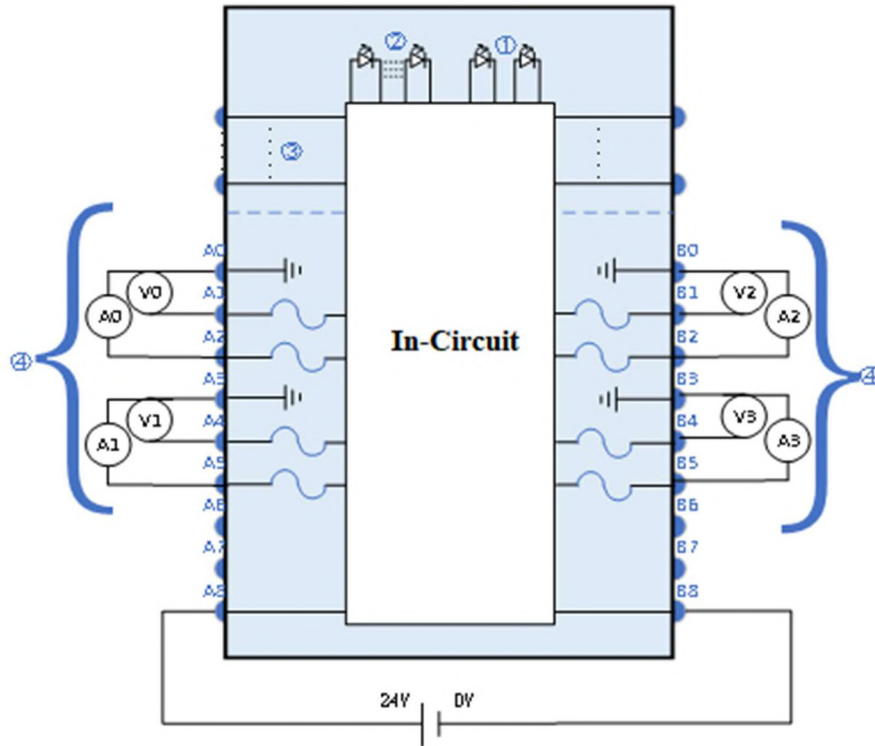

- ① System indicator ② Channel indicator light ③ Backplane bus ④ Output Channel & Wiring

5.3.5.3 Installation method

1) Installation requirements

The module is installed using DIN rails, which must comply with the IEC 60715 standard (35mm wide, 1mm thick), the size information is shown in the following figure, in millimeters.

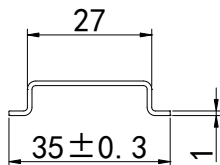

Note

When the module is installed on a non recommended DIN rail, the DIN rail latch may not lock properly.

2) Installation steps

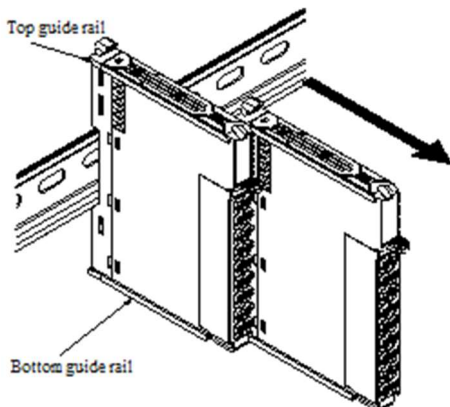

1. The assembly between IO modules is installed by sliding through the top and bottom guide rails of the modules, as shown in the left figure:

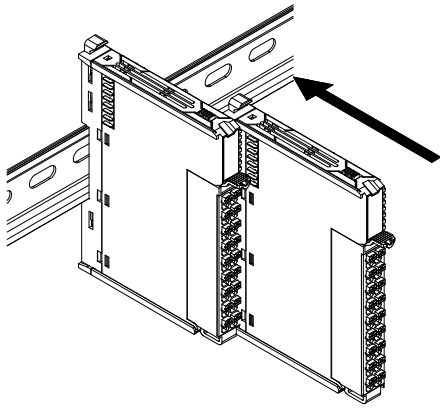

2. The module is installed on the guide rail. When installing, align the module with the DIN guide rail and press the module in the direction indicated by the arrow. After installation, there is a clear sound of engagement, as shown in the left figure:

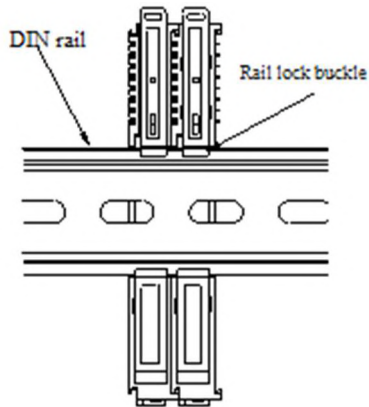

Explanation: After the module installation is completed, the locking buckle will automatically move downwards for locking, if the latch does not move downwards, press down on the top of the latch, ensure proper installation.

3) Disassembly steps

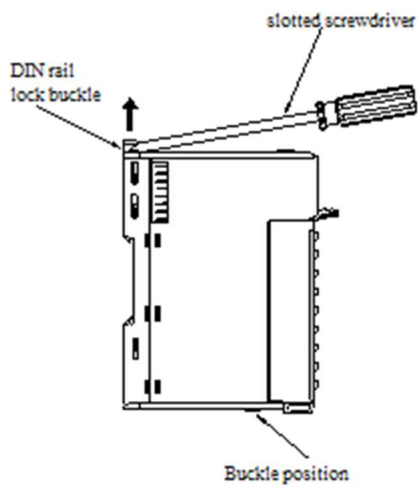

1. Use a flat screwdriver or similar tool to pry the rail lock upwards, as shown in the left figure:

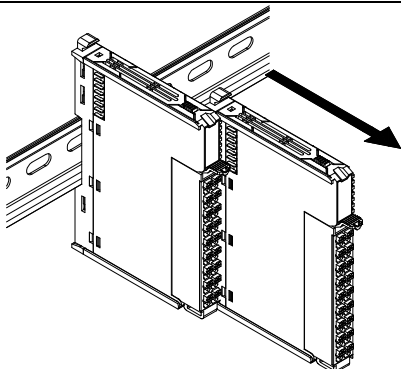

2. Pull the module straight forward at the buckle position (raised part), and then press down on the top of the latch, as shown in the left figure:
-

5.3.5.4 Installation environment

This product can be installed in four positions (i.e. installation direction): horizontal, vertical, top of cabinet, and bottom of cabinet. It is recommended to install in the horizontal direction, and the heat dissipation design is through natural convection. To ensure normal ventilation and heat dissipation and reserve sufficient wiring space, the minimum gap must be left around this product, as shown in the following figure:

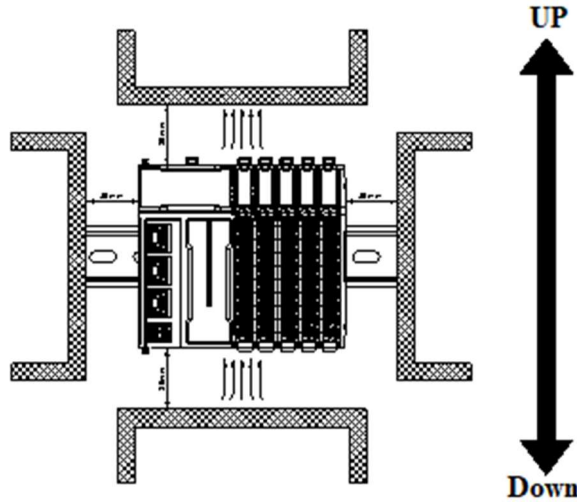

If there are high-temperature heat source equipment (heaters, transformers, large resistors, etc.) around this product, leave at least 100mm gap between the equipment and the high-temperature heat source.

5.3.5.5 Equipment wiring

When wiring the module, its terminal must meet the following requirements:

Adaptor diameter	
National standard/mm ²	American standard/AWG
0.3	22
0.5	20
0.75	18
1.0	18
1.5	16

If using other tube type wire ears, please crimp them to the twisted wire. The shape and size requirements are shown in the following figure:

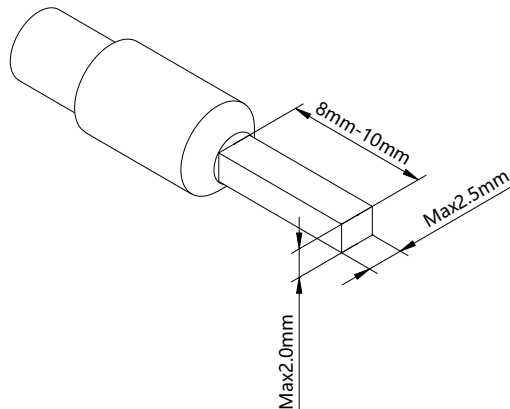

5.3.6 Usage of XF-E4DA and LFC3-AP

5.3.6.1 Process data mapping (PDO)

Name	Type	Explanation
XF_E4DA	Stuct	4-channel output module
CH0	DINT	Channel 0 output value
CH1	DINT	Channel 1 output value
CH2	DINT	Channel 2 output value
CH3	DINT	Channel 3 output value
ErrCode_module	WORD	Module level error codes
ErrCode_CH	DWORD	Channel level error code

■ Error code parameters

Module level error codes (ErrCode_module)		
Bit position	Meaning	Error level
0	The 24V input power supply of the module is abnormal	Important
2	Internal module error occurred and cannot be fixed by the user layer	Important
3	Version mismatch	Important
4	ADC/DAC read/write failure	Important

5.3.6.2 Module configuration parameters (SDO)

Parameter	Type	Channel	Note
Power detection	Enumeration of BYTE	--	0: Close 1: Open
Channel enable/disable	BYTE	Channel 0-4	0: Close 1: Open
Output type and range	BYTE		0: 0~10V (Default) 4: 1~5V 1: 0~5V 5: 0~20mA 2: -10~10V 6: 4~20mA 3: -5~5V
In the STOP state, the output remains at the previous value/preset value	Enumeration of BYTE		0: Keep the previous value 1: Set value
Presets	DINT		-32000~64000
Calibration enable/disable	Enumeration of BYTE		0: Close 1: Open
Calibration 1 analog quantity	INT		Voltage output 0~10V: Analog range: 0-10000mV Digital range: 0-64000
Calibration 1 digital quantity	DINT		0~5V: Analog range: 0-5000mV Digital range: 0-64000
Calibration 2 Analog Quantity	INT		-10~10V: Analog range: -10000-10000mV Digital range: -32000-32000
Calibration 2 Digital Quantity	DINT		-5~5V: Analog range: -5000-5000mV Digital range: -32000-32000
			1~5V: Analog range: 0mV-5000mV Digital range: 12800-64000
			Current output 0~20mA: Analog range: 0-20000uA Digital range: 0-64000 4~20mA: Analog range: 0-20000uA Digital range: 12800-64000
Enable/disable unit display conversion	Enumeration of BYTE		0: Close 1: Open
Unit display conversion limit	DINT		Range: -100000000~100000000 And after enabling unit conversion, (Upper Lower Limit)>0
Unit Display Conversion Lower Limit			

- Module power supply detection
- Check if the external 24V power supply of the module is normal:
 - ◆ Normal: The module is running normally.
 - ◆ Exception: The module channel cannot be used but can be configured, configured, and scanned normally.
- Can set parameters: enable or disable (default is disabled).

Launch parameters IO Mapping COE-Online

Advanced options

Index:SubIndex	Name	Flag	Value	Communication error message
#x8031:00	Module	rw	>1<	
01	Power Detection	rw		Communication not established
#x8032:00	Channel 0	rw	>12<	
15	Channel enable/disable	rw		Communication not established
16	Output Range and Type	rw		Communication not established
17	In the STOP state, the output remains at the previous...	rw		Communication not established
18	Presets	rw		Communication not established
1C	Calibration enable/disable	rw		Communication not established
1D	Calibration 1 Analog Quantity	rw		Communication not established
1F	Calibration 1 Digital Quantity	rw		Communication not established
23	Calibration 2 Analog Quantity	rw		Communication not established
25	Calibration 2 Digital Quantity	rw		Communication not established
29	Enable/disable unit display conversion	rw		Communication not established
2A	Unit display conversion limit	rw		Communication not established
2E	Unit Display Conversion Lower Limit	rw		Communication not established

■ Channel enable/disable

Enable or disable AD sampling channels to save module sampling time.

Launch parameters IO Mapping COE-Online

Advanced options

Index:SubIndex	Name	Flag	Value	Communication error message
#x8031:00	Module	rw	>1<	
01	Power Detection	rw		Communication not established
#x8032:00	Channel 0	rw	>12<	
15	Channel enable/disable	rw		Communication not established
16	Output Range and Type	rw		Communication not established
17	In the STOP state, the output remains at the previous...	rw		Communication not established
18	Presets	rw		Communication not established
1C	Calibration enable/disable	rw		Communication not established
1D	Calibration 1 Analog Quantity	rw		Communication not established
1F	Calibration 1 Digital Quantity	rw		Communication not established
23	Calibration 2 Analog Quantity	rw		Communication not established
25	Calibration 2 Digital Quantity	rw		Communication not established
29	Enable/disable unit display conversion	rw		Communication not established
2A	Unit display conversion limit	rw		Communication not established
2E	Unit Display Conversion Lower Limit	rw		Communication not established

Settable parameters	Enable/disable (in disable mode, subsequent software functions for the corresponding channel cannot be set)
Default parameters	Enable
Note	The conversion time for each channel is 60us, Total time=On/Off conversion speed * Number of enabled channels, if this channel is not used, it can be set to "disable" to reduce the total conversion time of the module

■ Output type/range

Can choose different output types and output ranges.

Index:SubIndex	Name	Flag	Value	Communication error message
#x8031:00	Module	rw	>1<	
01	Power Detection	rw		Communication not established
#x8032:00	Channel 0	rw	>12<	
15	Channel enable/disable	rw		Communication not established
16	Output Range and Type	rw		Communication not established
17	In the STOP state, the output remains at the previous...	rw		Communication not established
18	Presets	rw		Communication not established
1C	Calibration enable/disable	rw		Communication not established
1D	Calibration 1 Analog Quantity	rw		Communication not established
1F	Calibration 1 Digital Quantity	rw		Communication not established
23	Calibration 2 Analog Quantity	rw		Communication not established
25	Calibration 2 Digital Quantity	rw		Communication not established
29	Enable/disable unit display conversion	rw		Communication not established
2A	Unit display conversion limit	rw		Communication not established
2E	Unit Display Conversion Lower Limit	rw		Communication not established

Settable parameters	Configure the corresponding index objects in COE-Online, startup parameters, or SDO read and write instructions: voltage, current
Default parameters	0V~10V
Voltage measurement range	0V~5V, 0V~10V, -5V~5V, -10V~10V, 1V~5V Default: 0V~10V
Current measuring range	0mA~20mA, 4mA~20mA

■ STOP output

- When the CPU unit is in STOP mode or abnormal error mode, the corresponding DA channel of the module outputs according to the set parameters.
- Can set parameters: maintain the previous value, set value (default to maintain the previous value).

Index:Su...	Name	F.	V...	Communication error message
#x8031:00	Module	rw	>1<	
01	Power Detection	rw		Communication not established
#x8032:00	Channel 0	rw	>12<	
15	Channel enable/disable	rw		Communication not established
16	Output Range and Type	rw		Communication not established
17	In the STOP state, the output remains at the previous value/preset value	rw		Communication not established
18	Presets	rw		Communication not established
1C	Calibration enable/disable	rw		Communication not established
1D	Calibration 1 Analog Quantity	rw		Communication not established
1F	Calibration 1 Digital Quantity	rw		Communication not established
23	Calibration 2 Analog Quantity	rw		Communication not established
25	Calibration 2 Digital Quantity	rw		Communication not established
29	Enable/disable unit display conversion	rw		Communication not established
2A	Unit display conversion limit	rw		Communication not established
2E	Unit Display Conversion Lower Limit	rw		Communication not established
#x8033:00	Channel 1	rw	>12<	
#x8034:00	Channel 2	rw	>12<	
#x8035:00	Channel 3	rw	>12<	
#x9030:00	Information of 4DA	ro	>17<	

■ Calibration function

Index:Su...	Name	F.	V...	Communication error message
#x8031:00	Module	rw	>1<	
01	Power Detection	rw		Communication not established
#x8032:00	Channel 0	rw	>12<	
15	Channel enable/disable	rw		Communication not established
16	Output Range and Type	rw		Communication not established
17	In the STOP state, the output remains at the previous value/preset value	rw		Communication not established
18	Presets	rw		Communication not established
1C	Calibration enable/disable	rw		Communication not established
1D	Calibration 1 Analog Quantity	rw		Communication not established
1F	Calibration 1 Digital Quantity	rw		Communication not established
23	Calibration 2 Analog Quantity	rw		Communication not established
25	Calibration 2 Digital Quantity	rw		Communication not established
29	Enable/disable unit display conversion	rw		Communication not established
2A	Unit display conversion limit	rw		Communication not established
2E	Unit Display Conversion Lower Limit	rw		Communication not established

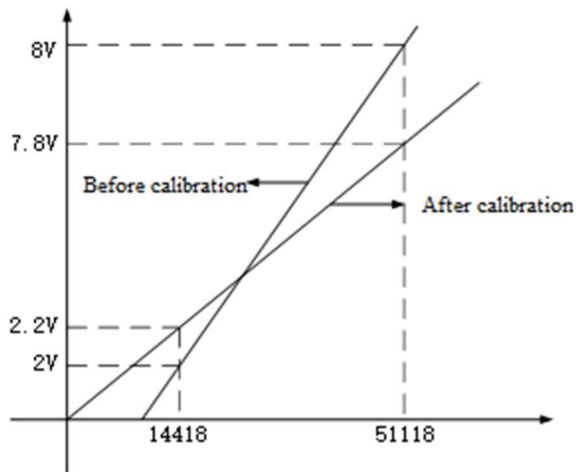

Due to the possibility of drift between the analog quantity obtained from DA output conversion and the set digital quantity after the product leaves the factory or has been used for a period of time, customers can set the DA offset calibration function, immediately reflect to the scaling value (numerical operation value), can easily complete the calibration during system startup on your own.

For example, if DA1 Analog output is set to 0-10V output, and 51118 is assigned to the output channel, the output voltage is 8V. When a value of 14418 is assigned to the output channel, the output voltage is 2V. At this point, set 8000mV in the analog setting of DA1 calibration 1, set 51118 in the DA1 calibration 1 digital quantity setting value, set 2000mV in the analog settings of DA1 calibration 2, set 14418 in the digital quantity settings of DA1 calibration 2, the calibration function can be achieved.

■ Unit display conversion

This function can directly display the output analog data as the actual output unit required by the customer.

Due to the fact that the customer's use of analog expansion module DA outputs mostly analog signals corresponding to the outputs of some instruments or sensors. For example, controlling the frequency output range of a frequency converter to be 0-50Hz, and controlling the output frequency of the frequency converter to control the analog signal to be 4-20mA, the existing DA module will output a 4-20mA analog signal to the analog acquisition terminal of the frequency converter, the customer needs to convert the digital quantity from 0 to 65535 to 0 to 50Hz for the actual output frequency of the frequency converter. It is possible to automatically convert the analog output of module DA into the actual output frequency value of the frequency converter by setting the conversion value range.

Index:Su...	Name	F.	V...	Communication error message
#x8031:00	Module	rw	>1<	
01	Power Detection	rw		Communication not established
#x8032:00	Channel 0	rw	>12<	
15	Channel enable/disable	rw		Communication not established
16	Output Range and Type	rw		Communication not established
17	In the STOP state, the output remains at the previous value/preset value	rw		Communication not established
18	Presets	rw		Communication not established
1C	Calibration enable/disable	rw		Communication not established
1D	Calibration 1 Analog Quantity	rw		Communication not established
1F	Calibration 1 Digital Quantity	rw		Communication not established
23	Calibration 2 Analog Quantity	rw		Communication not established
25	Calibration 2 Digital Quantity	rw		Communication not established
29	Enable/disable unit display conversion	rw		Communication not established
2A	Unit display conversion limit	rw		Communication not established
2E	Unit Display Conversion Lower Limit	rw		Communication not established

5.3.7 Usage of XF-E4DA and LFP3-AP

5.3.7.1 Process data mapping

In the device view, the mapping addresses of module process data can be viewed, and the case mapping addresses are IB90-IB95 and QB64-QB79.

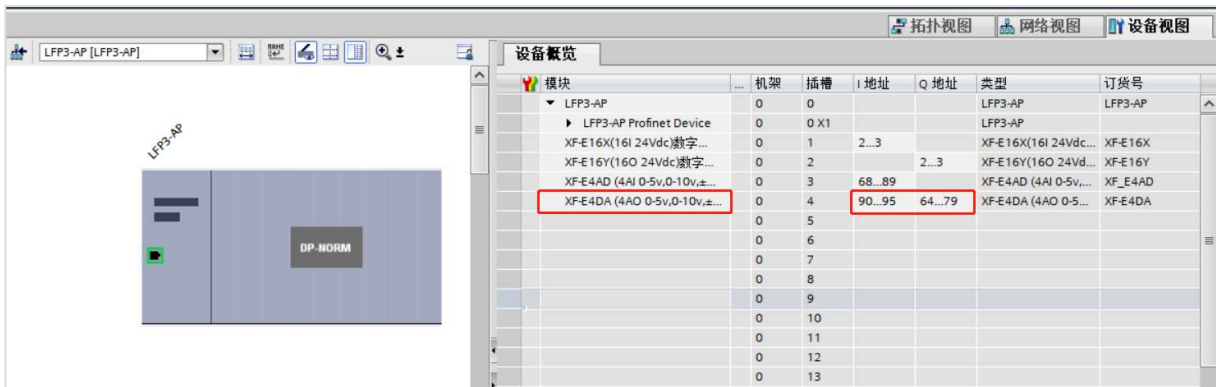

Name	Type	Explanation
XF_E4DA	Stuct	4-channel output module
QD64(QB64-QB67)	DINT	Channel 0 output value
QD68(QB68-QB71)	DINT	Channel 1 output value
QD72(QB72-QB75)	DINT	Channel 2 output value
QD76(QB76-QB79)	DINT	Channel 3 output value
ID90(IB90-IB91)	WORD	Module level error codes
ID92(IB92-IB95)	DWORD	Channel level error code

■ Error code parameters

Module level error codes (ErrCode_module)		
Bit position	Meaning	Error level
0	The 24V input power supply of the module is abnormal	Important
2	Internal module error occurred and cannot be fixed by the user layer	Important

Module level error codes (ErrCode_module)		
Bit position	Meaning	Error level
3	Version mismatch	Important
4	ADC/DAC read/write failure	Important

5.3.7.2 Module configuration parameters

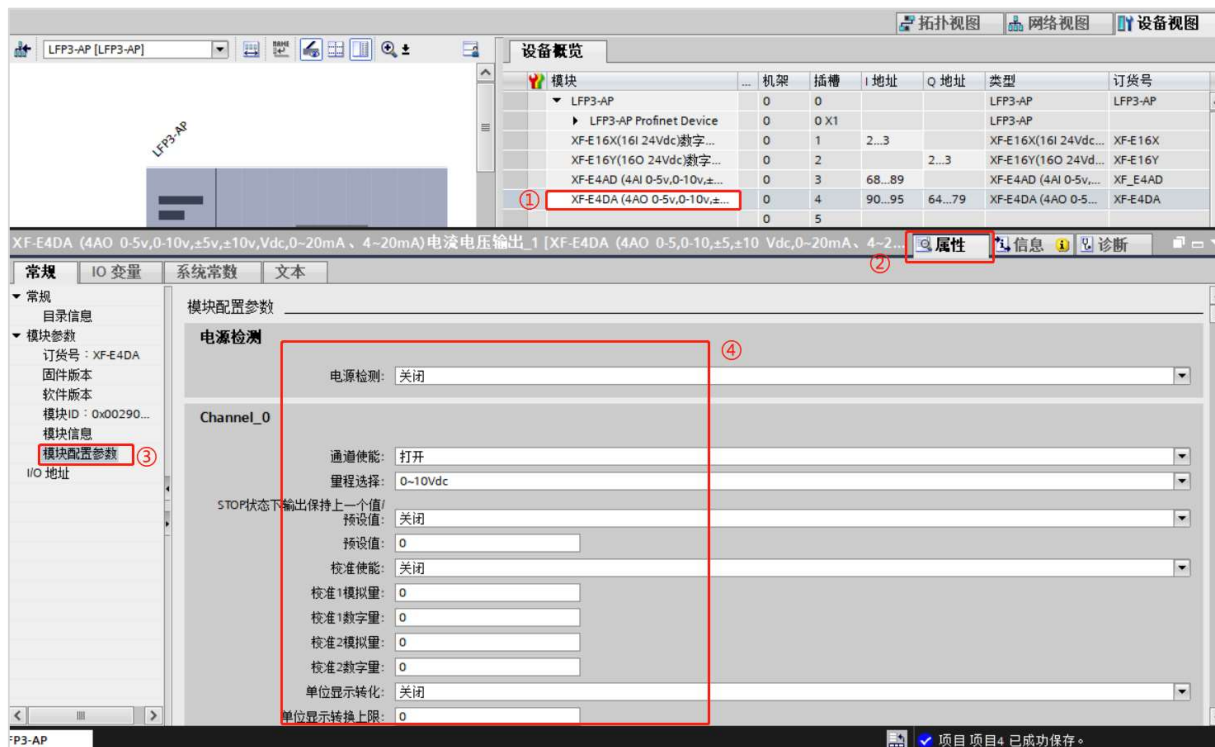

- Module power supply detection
 - Check if the external 24V power supply of the module is normal:
 - ◆ Normal: The module is running normally;
 - ◆ Exception: The module channel cannot be used but can be configured, configured, and scanned normally.
 - Parameters can be set: enable or disable (default is disabled).
- Channel enable/disable

Enable or disable AD sampling channels to save module sampling time.

Settable parameters	Enable/disable (in disable mode, subsequent software functions for the corresponding channel cannot be set)
Default parameters	Enable
Note	The conversion time for each channel is 60us, total time=On/Off conversion speed * Number of enabled channels, if this channel is not used, it can be set to "disable" to reduce the total conversion time of the module.

- Output type/range

Can choose different output types and output ranges.

Settable parameters	The following table pulling method reflects the adjustable parameters: voltage, current
Default parameters	0V~10V
Voltage measurement range	0V~5V, 0V~10V, -5V~5V, -10V~10V, 1V~5V Default: 0V~10V
Current measuring range	0mA~20mA, 4mA~20mA

■ STOP output

- When the CPU unit is in STOP mode or abnormal error mode, the corresponding DA channel of the module outputs according to the set parameters.
- Can be set parameters: Keep the previous value, set value (default to keep the previous value).

■ Calibration function

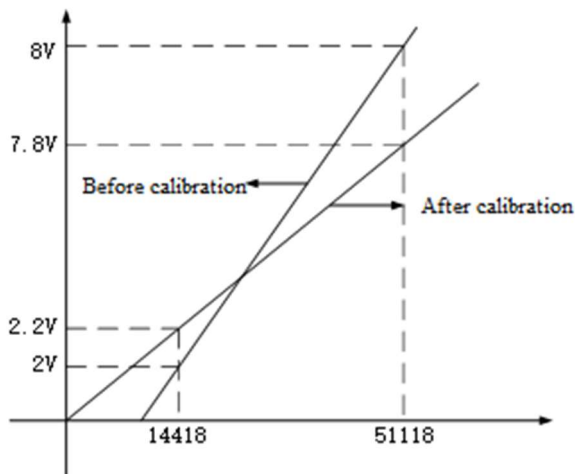

Due to the possibility of drift between the analog quantity obtained from DA output conversion and the set digital quantity after the product leaves the factory or has been used for a period of time, customers can set the DA offset calibration function, immediately reflect to the proportional scaling value (numerical operation value), and you can easily complete the calibration at system startup on your own.

For example, setting the DA1 analog output to 0-10V output, when a value of 51118 is assigned to the output channel, the output voltage is 8V. When a value of 14418 is assigned to the output channel, the output voltage is 2V. At this point, set 8000mV in the analog setting of DA1 calibration 1, set 51118 in the DA1 calibration 1 digital quantity setting value, set 2000mV in the analog settings of DA1 calibration 2, set 14418 in the digital quantity settings of DA1 calibration 2, the calibration function can be achieved.

■ Unit display conversion

This function can directly display the output analog data as the actual output unit required by the customer.

Due to the fact that the customer's use of analog expansion module DA outputs mostly analog signals corresponding to the outputs of some instruments or sensors. For example, controlling the frequency output range of a frequency converter to be 0-50Hz, and controlling the output frequency of the frequency converter to control the analog signal to be 4-20mA, the existing DA module will output a 4-20mA analog signal to the analog acquisition terminal of the frequency converter, the customer needs to convert the digital quantity from 0 to 65535 to 0 to 50Hz for the actual output frequency of the frequency converter. It is possible to automatically convert the analog output of module DA into the actual output frequency value of the frequency converter by setting the conversion value range.

XINJE



Wechat ID

WUXI XINJE ELECTRIC CO., LTD.

No. 816, Jianshe West Road, Binhu District,

Wuxi City, Jiangsu Province, China

214072

Tel: 400-885-0136

Fax: (510) 85111290

Email: fiona.xinje@vip.163.com

www.xinje.com