

# MISCOM6208-2S-SC20

## 8-Port Layer 2 Managed DIN-Rail Fast Industrial Ethernet Switch



- Support 6×100M copper ports and 2×100M fiber ports
- Support redundancy protocols like MW-Ring, ERPSv1/v2,
- STP/RSTP for ring network reliability
- MW- Ring allows networks to recover within 20ms
- Support QoS to allow 802.1P/DSCP/port-based priority mapping
- Support single AC85~264V/DC110~370V power supply,
- or dual DC9~60V redundant power input
- High strength aluminum alloy shell, IP40 protection grade
- Fanless design, case heat dissipation
- Work in -40°C ~ + 85°C harsh industrial environment.





## Product Description

MISCOM6208-2S-SC20 8-port Layer 2 managed industrial Ethernet switches, support 2 100Mbps fiber ports and 6 100Mbps copper ports. The switches adopt store-and-forward processing type, supporting wire-speed forwarding, fast and smooth data transmission, suitable for a variety of application scenarios. Through strictly selection, these industrial switches pick industrial-grade components, with high-standard system design and production control, 35mm standard DIN rail mounting, high-strength aluminum alloy shell, durable, fanless and efficient heat dissipation, -40°C ~ +85°C wide temperature (AC models -40°C ~ +75°C), high standard industrial protection design, able to adapt to a variety of harsh operating environments.

MISCOM6208-2S-SC20 can be managed via WEB or SNMP, and is equipped with a series of advanced management functions, such as MW-Ring, ERPS, STP/RSTP, VLAN, QoS, LLDP, IGMP Listening, WEB/ TELNET/ SSH Control, Port Aggregation, Port Mirroring, Port Statistics, Static Multicast, Network Diagnostics, Loopback Detection, Email Log, Relay Alarm and Firmware Online Upgrade. The products can be widely used in comprehensive energy, smart city, intelligent transportation, smart factory, industrial automation and other industrial fields.



## Features and Benefits

- Support rate limiting of packets from broadcast, multicast and unknown unicast, and storm detection of
  - broadcast and multicast packets
- Support QoS to manage quality and determine the priority of data traffic transmission on a network
- Support 802.1Q VLAN, provide Access, Trunk, Hybrid interface for multiple broadcast domains
- Support IGMP snooping and static multicast table, build Layer 2 multicast forwarding table to prevent
  - multicast data from broadcasting
- Support Link Layer Discovery Protocol (LLDP), to gather hardware information about neighboring
  - devices for link monitoring, to manage topology and fault locating
- Support ERPS technology, providing multi-ring networking for link backup, fast convergence and
  - improved network stability
- MW- Ring allows networks to recover within 20ms
- Support Rapid Spanning Tree Protocol (RSTP), compatible with STP, eliminate loops in network
- Support link static aggregation, to increase bandwidth and link reliability
- Support user permission management
- Support WEB control, HTTP, HTTPS access control, IP address login restriction
- Support TELNET, SSH access control, SSH provides secure remote login to ensure data integrity and
  - reliability
- Support bind static unicast/multicast MAC address to ports
- Support SNMPv1/v2c/v3 and SNMPv1/v2c/v3 TRAP
- Support relay alert of traffic storm, port drop, ring status, dual power fail etc,
- Support port calculate of varied data frame transmitted and received to realize the monitor of port traffic
- Support port mirroring for network monitoring and troubleshooting based on ingress and egress traffic
- Support loopback detection to detect loops before a network storm occurs, avoiding the risk and
  - inconvenience of traffic disruption
- Support system log of WEB, LINK, CONFIG, AUTH, IGMP, STORM, RING, RSTP, and SNMP etc.



## Specification

Software	
Switching	Support port rate, duplex mode and traffic configuration Support port-based VLAN and 802.1Q VLAN Support ingress/egress rate-limiting, storm detection, port static aggregation Support MAC address table, received frames/transmitted frames/total traffic statistics.
Redundancy	Support ERPS Support private ring network technology MW-Ring/ MW-RingV2 Support RSTP, compatible with STP
Multicast	Support IGMP snooping Support static multicast
Security Management	Support WEB, TELNET, SSH control Support static MAC port binding Support Email log, relay alert Support loopback test
Management and Maintenance	Support QoS, 802.1P/ DSCP/port-based priority mapping, relative and absolute priority control Support SNMP v1/v2c/v3, SNMP v1/v2c/v3 TRAP, LLDP Support port mirroring, Ping Support user permission management, local time management, SNTP client, log info Support online restart, factory reset, system upgrade, configuration file upload/download Support master computer software management
Switch Capability	
Processing Type	Store-and-Forward
Backplane Bandwidth	2Gbps
Buffer Size	1Mbit
MAC Table Size	2K
Interface	
100M Fiber Port	2×100Base-FX ports, single mode/multimode, SC connectors, wavelength, transmission distance are optional
100M Copper Port	6×10/100Base-T(X) auto-sensing RJ45 ports, support full/half duplex and auto MDI/ MDI-X
Relay	1 relay alarm output, 3.81mm pitch 3 pin terminal block
CONSOLE	1* CONSOLE port, RS-232 serial port with an RJ-45 connector
Button	Factory reset
Status LED	Power, running status, alert, fiber port indicator, copper port rate, connection status

Power Supply	
Input Voltage	DC models: DC9~60V, dual power input, non-polarity
Power Consumption	<5W@DC24V
Connection	5.08mm pitch 5-pin terminal blocks with lock mechanism
Physical Characteristics	
Dimensions	140×54×110mm (DIN rail mounting clip excluded)
Installations	35mm DIN rail mounting
IP Code	IP 40
Weight	0.6kg
Working Environment	
Operating Temp	-40°C~+85°C (AC models -40°C~+75°C)
Storage Temp	-40°C~+85°C
Relative Humidity	5%~95% (non-condensing)
Industry Standard	
EMC	IEC 61000-4-2(ESD): Level 4 IEC 61000-4-5(Surge): Level 4 (AC models Level 3) *Ethernet ports support 6kV surge protection IEC 61000-4-4(EFT): Level 4
Certification	CE, FCC, RoHS



## Dimensions

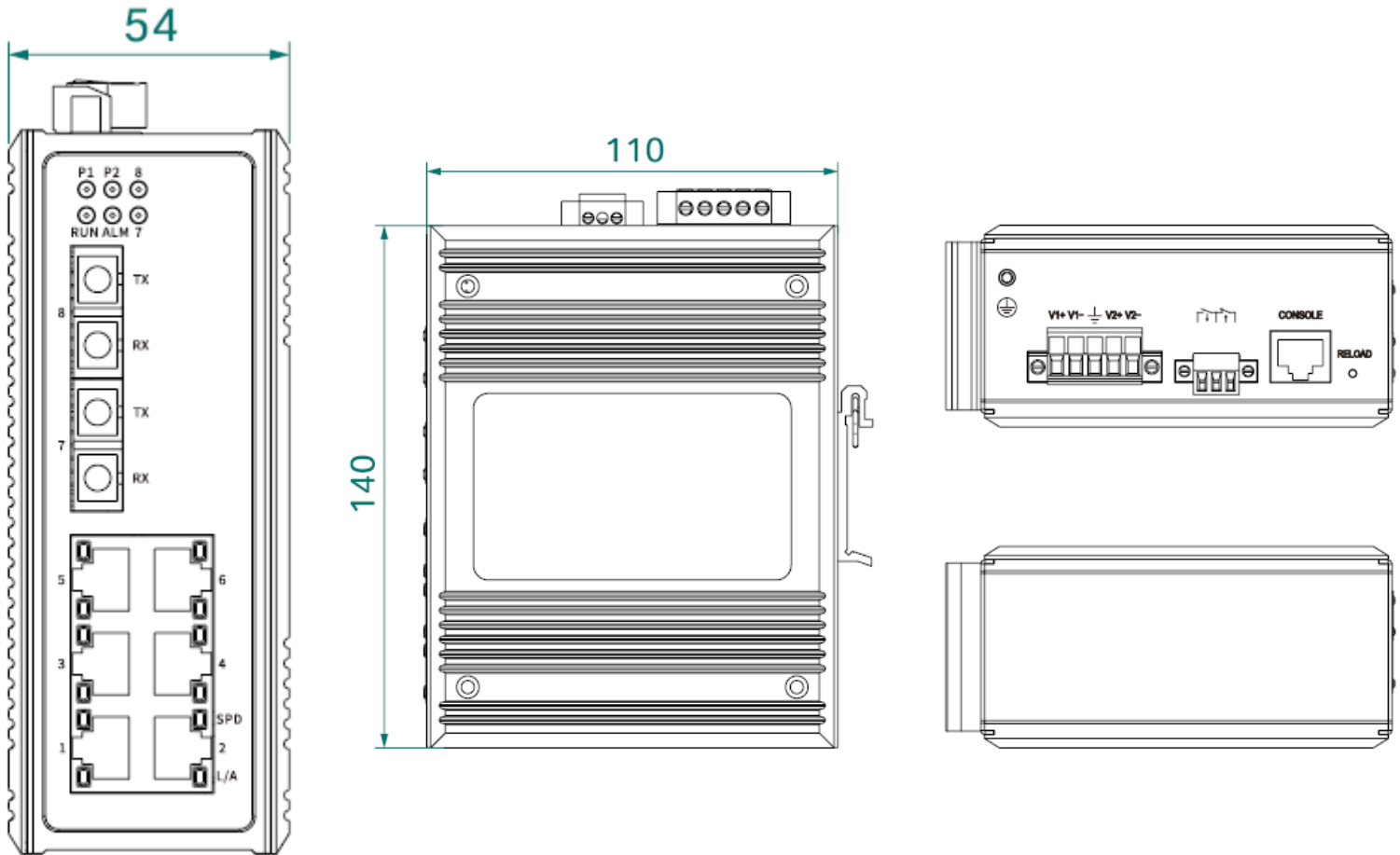

## Contact Us

### Wuhan Maiwe Communication Co., Ltd

Address: No.52 Liufang Avenue, East lake High-techDevelopment Zone, Wuhan, China.

Tel: 027 8717 0217

Mail: [enquiry@maiwe.com](mailto:enquiry@maiwe.com)

Official site: [www.maiwe.com](http://www.maiwe.com)

Copyright © Maiwe Communication All rights reserved