

# DSCA39

## Current Output Signal Conditioners



### Description

Each DSCA39 current output module provides a single channel of analog output. The input signal is buffered, isolated, filtered and converted to a unipolar or bipolar current output. Signal filtering is accomplished with a five-pole filter which provides 100dB per decade of attenuation above 1kHz. An anti-aliasing pole is located on the system side of the isolation barrier, and the other four poles are on the field side. After the initial system-side filtering, the input signal is chopped by a proprietary chopper circuit. Isolation is provided by transformer coupling, again using a proprietary technique to suppress transmission of common mode spikes or surges.

Special output circuits provide protection against accidental connection of power-line voltages up to 240VAC and against transient events as defined by ANSI/IEEE C37.90.1. Protection circuits are also present on the signal input and power input terminals to guard against transient events and power reversal. Signal and power lines are secured to the module using screw terminals which are in pluggable terminal blocks for ease of system assembly and reconfiguration.

The modules have excellent stability over time and do not require recalibration, however, zero and span settings are adjustable up to  $\pm 5\%$  to accommodate situations where fine-tuning is desired. The adjustments are made using potentiometers located under the front panel label and are non-interactive for ease of use.

### ► Features

- Accepts High-Level Voltage Input
- Provides 4 to 20mA, 0 to 20mA, or -20 to +20mA Output
- ANSI/IEEE C37.90.1 Transient Protection
- 1500Vrms Transformer Isolation
- $\pm 0.03\%$  Accuracy
- $\pm 0.01\%$  Linearity
- Output Protected to 240VAC Continuous
- True 3-Way Isolation
- Wide Range of Supply Voltage
- 100dB CMR
- Easily Mounts on Standard DIN Rail
- C-UL-US Listed
- CE and ATEX Compliant

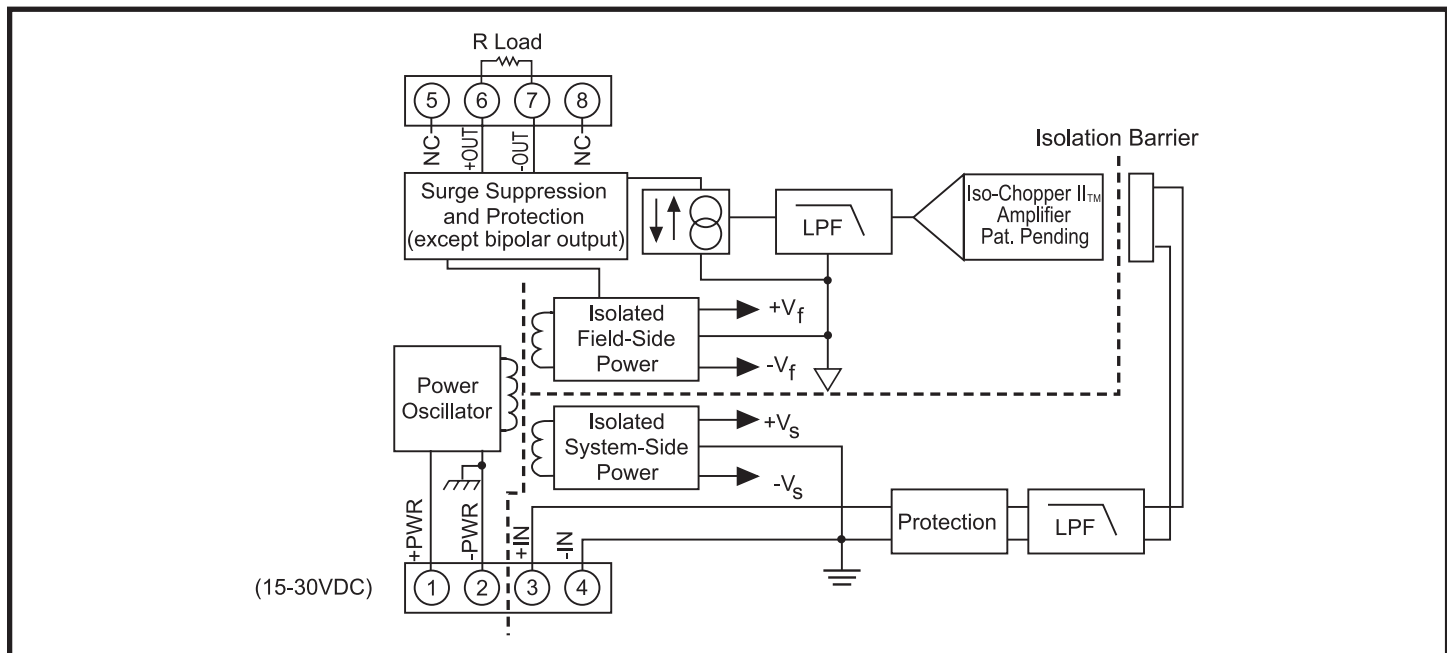

Figure 1: DSCA39 Block Diagram

**Specifications**

 Typical at  $T_A=+25^{\circ}\text{C}$  and +24V supply voltage

Model	DSCA39-01, -02, -03, -04	DSCA39-05	DSCA39-07
Output Range	4 to 20mA or 0 to 20mA	0 to 20mA	-20mA to +20mA
Over Range Capability	10%	*	5%
Output Compliance Voltage (Open Circuit)	22VDC	*	±15VDC
Load Resistance Range	0 to 750Ω	*	0 to 500Ω
Output Protection			
Continuous	240Vrms max	*	*
Transient	ANSI/IEEE C37.90.1	*	*
Input Range	±10V or 0V to +10V	0 to 20mA	±10V
Input Resistance			
Normal	2MΩ	<100Ω	*
Power Off	2MΩ	<100Ω	*
Overload	2MΩ	65kΩ	*
Input Protection			
Continuous	±35V max	75mA	*
Transient	ANSI/IEEE C37.90.1	*	*
CMV, Output to Input, Output to Power			
Continuous	1500Vrms max	*	*
Transient	ANSI/IEEE C37.90.1	*	*
CMV, Input to Power			
Continuous	50VDC max	*	*
CMR (50Hz or 60Hz)	110dB	*	*
Accuracy <sup>(1)</sup>	±0.03% Span	*	±0.05%
Linearity	±0.01% Span	*	*
Adjustability	±5% Zero and Span	*	*
Stability			
Offset	±20ppm/°C	*	*
Gain	±40ppm/°C	±50ppm/°C	*
Output Noise, 100kHz Bandwidth	4μArms	*	*
Bandwidth, -3dB	1kHz	*	*
NMR	100dB/Decade Above 1kHz	*	*
Response Time, 90% Span	475μs	*	*
Power Supply			
Voltage	15 to 30VDC	*	19 to 29VDC
Current	65mA	*	*
Sensitivity	±0.0003%/%	*	*
Protection			
Reverse Polarity	Continuous	*	*
Transient	ANSI/IEEE C37.90.1	*	*
Environmental			
Operating Temperature Range	-40°C to +80°C	*	*
Storage Temperature Range	-40°C to +80°C	*	*
Relative Humidity	0 to 95% Noncondensing	*	*
Emissions EN61000-6-4	ISM, Group 1	*	*
Radiated, Conducted	Class A	*	*
Immunity EN61000-6-2	ISM, Group 1	*	*
RF	Performance A ±0.5% Span Error	*	*
ESD, EFT	Performance B	*	*
Mechanical Dimensions (h)(w)(d)	2.95" x 0.89" x 4.13" (75mm x 22.5mm x 105mm)	*	*
Mounting	DIN EN 50022 -35x7.5 or -35x15 rail	*	*

## NOTES:

\* Same specification as DSCA39-01, -02, -03, -04

(1) Includes linearity, hysteresis and repeatability.

**Installation Notes:**

- 1.) This Equipment is Suitable for Use in Class I, Division 2, Groups A, B, C, D, or Non-Hazardous Locations Only.
- 2.) Warning - Explosion Hazard - Substitution of Components May Impair Suitability for Class I, Division 2.
- 3.) Warning - Explosion Hazard - Do Not Disconnect Equipment Unless Power Has Been Switched Off or The Area is Known to be Non-Hazardous.

**Ordering Information**

Model	Input Range	Output Range
DSCA39-01	0V to +10V	4mA to 20mA
DSCA39-02	-10V to +10V	4mA to 20mA
DSCA39-03	0V to +10V	0mA to 20mA
DSCA39-04	-10V to +10V	0mA to 20mA
DSCA39-05	0mA to 20mA	0mA to 20mA
DSCA39-07	-10V to +10V	-20mA to +20mA