

# **NewPre2100 5G**

## **Edge General-Purpose Controller**

### **Hardware Installation Manual**

Publication date: April 2022

Issue: V1.2

No. : 112028563

Publication unit: Kyland Technology Co., Ltd.

Address: Floor 9, Building 2, Yard 30, Xishanhui, Shijingshan  
District, Beijing

Website: <http://www.kyland.com.cn>

<http://www.kyland.cn>

Customer service hotline: (+8608) 88798888

Email: [support@kyland.com](mailto:support@kyland.com)

The logo for KYLAND, featuring the word "KYLAND" in a bold, italicized, sans-serif font.

## **Preface**

This manual provides you with hardware installation instructions for the NewPre2100 5G Edge General-Purpose Controller.

## Legal Statement

Kyland Technology Co., Ltd.. reminds you to carefully read and fully understand the terms of this Legal Statement before reading or using this document.

If you read or use this document, your reading or use will be deemed to be an endorsement of the entire contents of this Statement.

You should obtain this document through the legally authorized channels provided by Kyland Technology Co., Ltd.. The content of this document is regarded as the confidential information of Kyland Technology Co., Ltd., and you shall strictly abide by the confidentiality obligation; Without the prior written consent of Kyland Technology Co., Ltd., you may not disclose the contents of this Manual to or provide it to any third party for use.

1. The copyright of this manual belongs to Kyland Technology Co., Ltd.. Without prior written permission, no unit, company or individual may extract, translate or reproduce part or all of the contents of this document in any way, or disseminate and promote it in any way or manner, or distribute it for commercial purposes, etc.
2. The content of this document is subject to change due to product version upgrade, adjustment, or other reasons. Beijing Kyland Science & Technology Co., Ltd. reserves the right to modify the contents of this document without any notice or prompt, and to publish updated user documents from time to time in the channels authorized by Beijing Kyland Science & Technology Co., Ltd. You should pay attention to the version changes of the user documentation in real time and obtain the latest version of the user documentation through the authorized channels of Kyland Technology Co., Ltd..
3. This document is intended only as a reference guide for users to use the products and services of Kyland Technology Co., Ltd.. Based on existing technology, Kyland Technology Co., Ltd.. tries its best to provide relevant introduction and operation guidance. However, Kyland Technology Co., Ltd.. hereby expressly declares that the accuracy, completeness, applicability and reliability of the contents of this document are not guaranteed by any express or implied warranties. Kyland Technology Co., Ltd.. shall not assume any legal liability for any errors or economic losses caused by the use or reliance of this document by any unit, company or individual. In no event shall Beijing east earth technology corporation be liable for any indirect, consequential, exemplary, incidental, special or punitive damages, including lost profits, arising out of the user's use of or reliance on this document (even if Beijing east earth technology corporation has been

advised of the possibility of such damages).

4. If you find any technical errors or clerical errors in this document, please contact Kyland Technology Co., Ltd., and we will try our best to correct them in time.
5. Infringement shall be prosecuted.

**Copyright © 2022 Kyland Technology Co., Ltd.**

## Notice for Safe Use

This product has good and reliable performance within the designed range of use, but it is necessary to avoid damage or destruction caused by man to the device. Before using the device, read this manual carefully to ensure the safety of the user and the device. Please keep this manual after reading for future reference. Our company does not assume any responsibility for personal injury or device damage caused by violation of safety instructions.

- Do not place or install the device near water sources or in humid places, and keep the relative humidity around the device within the range of 5% to 95% and without condensation.
- Do not place or install the device in a place with high magnetic field, strong earthquake, or high temperature. Keep the device operating and storage temperature within the specified range.
- Keep the device securely placed to prevent falling; Keep the device securely installed to prevent slippage.
- Keep the device and surrounding environment clean. Wipe with soft dry cotton cloth if necessary.
- Please do not place debris on the device or cables, keep the device heat dissipation smooth and the cables smooth and free of knots.
- Wear antistatic gloves or take other safety precautions when operating the device.
- When connecting cables, avoid exposed metal wires to prevent high temperature oxidation or combined electricity of metal wires.
- Install device in accordance with national and local electrical regulations.
- Before powering on the device, check the power specifications supported by the device to prevent the device from being damaged due to overvoltage.
- Keep the power plug and other device connectors securely connected to prevent adverse effects of contact.
- Do not remove or plug the power supply with wet hands. Do not touch the device or its components with wet hands before the power is off.
- Before operating live device, remove jewelry (rings, bracelets, watches, necklaces, etc.) or other metal objects to prevent electric shock or burns.

- Do not operate the device or connect or disconnect cables during lightning weather.
- Please use the connectors and cables approved by our marketing or technical support personnel to prevent the module functions from being affected due to the non-standard connectors and cables.
- Do not disassemble the device by yourself. If the device is faulty or suspected to be faulty, contact our marketing or technical support personnel.
- If the device components are lost, please purchase the replacement parts under the guidance of our marketing staff or technical support staff, it is strictly forbidden to choose the components by yourself.
- The device should be scrapped in accordance with relevant national regulations to reduce the pollution to the environment.

In the following cases, please disconnect the power supply immediately and contact us.

- The device is flooded.
- The device is broken or the casing is cracked.
- The device works abnormally or its performance changes.
- The device produces odor, smoke or abnormal noise.

# Table of Contents

Preface.....	2
Legal Statement .....	3
1 Product Overview .....	9
2 Structure and Interface.....	11
2.1 Front panel.....	11
2.2 Side panel .....	13
2.3 Top panel.....	14
3 Installation.....	16
3.1 Dimension drawing.....	16
3.2 Installation methods and procedures .....	17
3.2.1 Clamping rail installation .....	17
3.2.2 Wall-mounted.....	19
3.2.3 Antenna installation and SIM card installation .....	20
4 Wire.....	22
4.1 10/100/1000Base-T(X) Ethernet interface.....	22
4.2 RS-232/RS-485/RS-422 interface .....	23
4.3 USB connector.....	24
4.4 CAN interface.....	24
4.5 DI/DO interface .....	25
4.6 Console interface .....	26
4.7 Grounding.....	27
4.8 Power supply terminal .....	27
5 Reset.....	30
6 LED Indicator State .....	31

7 Basic Performance and Specifications ..... 32



# 1 Product Overview

NewPre2100 5G Edge General-Purpose Controller is a edge general-purpose server specially created by our company for 5G application field. Combining multiple functions such as communication routing, protocol gateway, edge computing, process control, motion control, and machine vision, its miniature size and compact performance make it especially suitable for industrial 5G field applications.

The NewPre2100 5G Edge General-Purpose Controller supports either card rail or wall mount, and the following configurations are supported for different device types.

When the code selection is NewPre2100-P521-M1-D0-W3, A maximum of six 10/100/1000Base-T(X) Ethernet interfaces, two RS-232/RS-422/RS-485 serial interfaces, one CPU debugging serial interface (Console interface), two USB3.0 interfaces, four 5G antenna installation interfaces, one WIFI antenna installation interface, and two CAN connections CAN be configured interface, two DI interfaces, two DO interfaces, and two SIM card slots.

When the code selection is NewPre2100-P521-M1-D0-W0, A maximum of four 10/100/1000Base-T(X) Ethernet interfaces, two RS-232/RS-422/RS-485 serial interfaces, one CPU debugging serial interface (Console interface), two USB3.0 interfaces, two CAN interfaces, and two SIM card installation slots can be configured.

The following table shows the specific configuration.

Table 1 Configuration table

Type of product	NewPre2100-P521-M1-D0-W3 NewPre2100-P521-M1-D0-W0
Code definition	Code selection
Electric port	When NewPre2100-P521-M1-D0-W3 is selected: 6 10/100/1000Base-T(X) electric ports, RJ45 When NewPre2100-P521-M1-D0-W0 is selected: 4 10/100/1000Base-T(X) electric ports, RJ45
serial interface	2 x RS232/485/422 One CPU debugging serial interface (Console interface)
USB Connector	2 USB3.0
Antenna interface	Four 5G antenna installation interfaces, one WIFI antenna installation interface (available only when selecting NewPre2100-P521-M1-D0-W3)

DI/DO interface	4-way DI/DO interfaces (2-way DI/DO interfaces, available only when selecting NewPre2100-P521-M1-D0-W3)
Other interfaces	Two SIM card slots
Operating temperature	-40°C~+75°C
PWR1-PWR2: power input	Terminal interface: 24V+, 24V-: 24V voltage input

## 2 Structure and Interface



**Note:**

In order to maintain the cleanliness of the interface and to protect the operational performance of the device, it is recommended that users order a separate interface dust cover (optional) according to the form of the device interface.

### 2.1 Front panel

- 5G Edge General-Purpose Controller NewPre2100-P521-M1-D0-W3 front panel

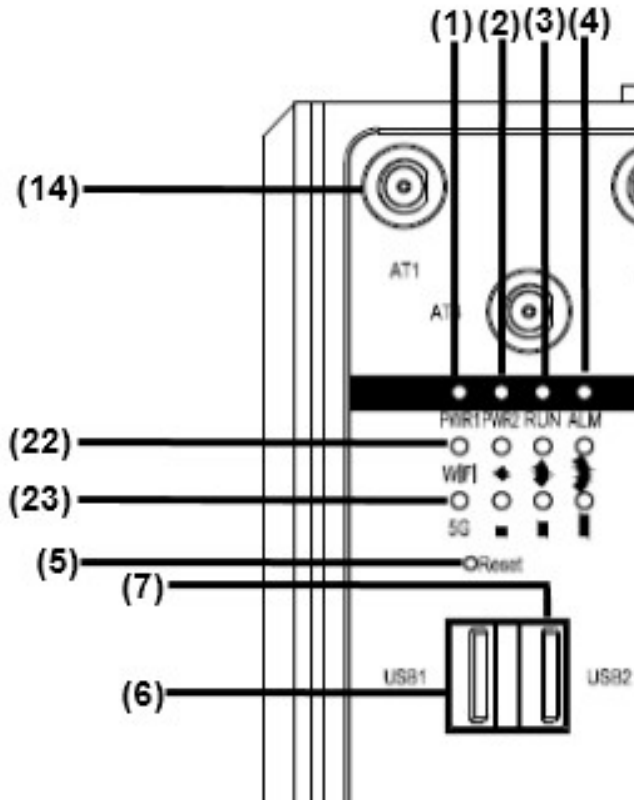

Figure 1 NewPre2100-P521-M1-D0-W3 front panel labeling diagram

Table 2 NewPre2100-P521-M1-D0-W3 front panel labeling instructions

No.	Identification	Description
(1)	PWR1	24V power input 1 indicator
(2)	PWR2	24V power input 2 indicator
(3)	RUN	Operation indicator
(4)	ALM	Alarm indicator
(5)	Reset	Reset button

(6)	USB1	USB3.0 communication interface 1
(7)	USB2	USB3.0 communication interface 2
(8)~(13)	1~6	10/100/1000Base-T(X) Ethernet communication interfaces 1 to 6
(14)	AT1~AT4	5G antenna installation interface
(15)	AT5	WIFI antenna installation interface
(16)	CAN1	CAN communication interface 1
(17)	CAN2	CAN communication interface 2
(18)	S1~S2	RS-232/485/422 communication interface
(19)	I/O	DI/DO communication interface
(20)	--	10/100/1000Base-T(X) Ethernet communication interface rate indicator (yellow)
(21)	--	10/100/1000Base-T(X) Ethernet communication interface connection state indicator (green)
(22)	WIFI	WIFI intensity indicator
(23)	5G	5G intensity indicator

- 5G Edge General-Purpose Controller NewPre2100-P521-M1-D0-W0 front panel

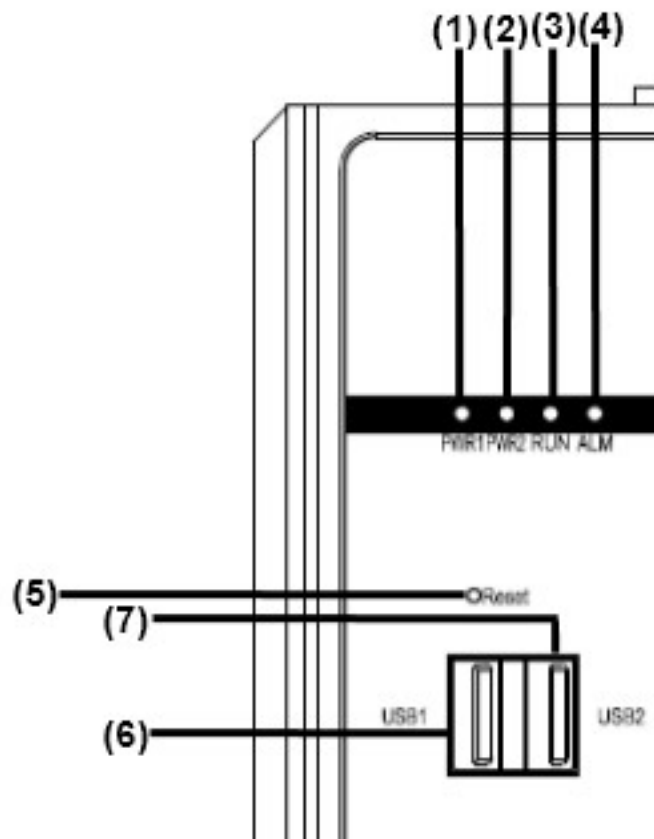

Figure 2 NewPre2100-P521-M1-D0-W0 front panel labeling diagram

Table 3 NewPre2100-P521-M1-D0-W0 front panel labeling instructions

No.	Identification	Description
(1)	PWR1	24V power input 1 indicator
(2)	PWR2	24V power input 2 indicator
(3)	RUN	Operation indicator
(4)	ALM	Alarm indicator
(5)	Reset	Reset button
(6)	USB1	USB3.0 communication interface 1
(7)	USB2	USB3.0 communication interface 2
(8)~(11)	1~4	10/100/1000Base-T(X) Ethernet communication interfaces 1 to 4
(14)	--	10/100/1000Base-T(X) Ethernet communication interface rate indicator (yellow)
(15)	--	10/100/1000Base-T(X) Ethernet communication interface connection state indicator (green)
(16)	CAN1	CAN communication interface 1
(17)	CAN2	CAN communication interface 2
(18)	S1~S2	RS-232/485/422 communication interface

## 2.2 Side panel

- 5G Edge General-Purpose Controller NewPre2100-P521-M1-D0-W3 /  
NewPre2100-P521-M1-D0-W0 side panel

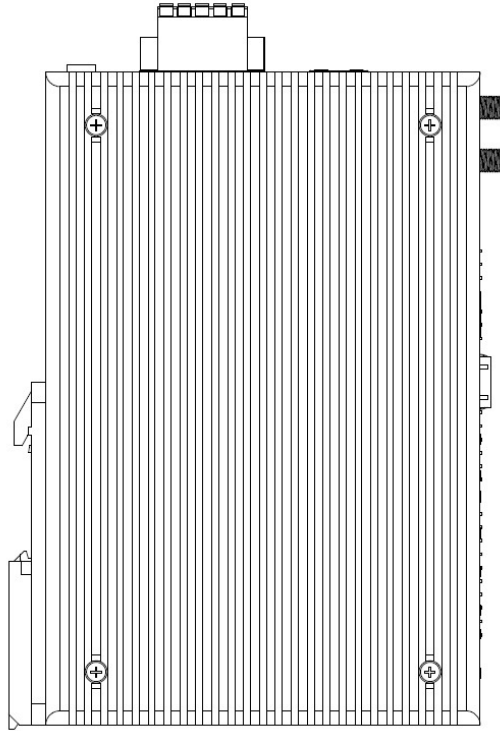

Figure 3 NewPre2100-P521-M1-D0-W3 / NewPre2100-P521-M1-D0-W0 side panel labeling diagram

## 2.3 Top panel

- 5G Edge General-Purpose Controller NewPre2100-P521-M1-D0-W3 / NewPre2100-P521-M1-D0-W0 Top panel

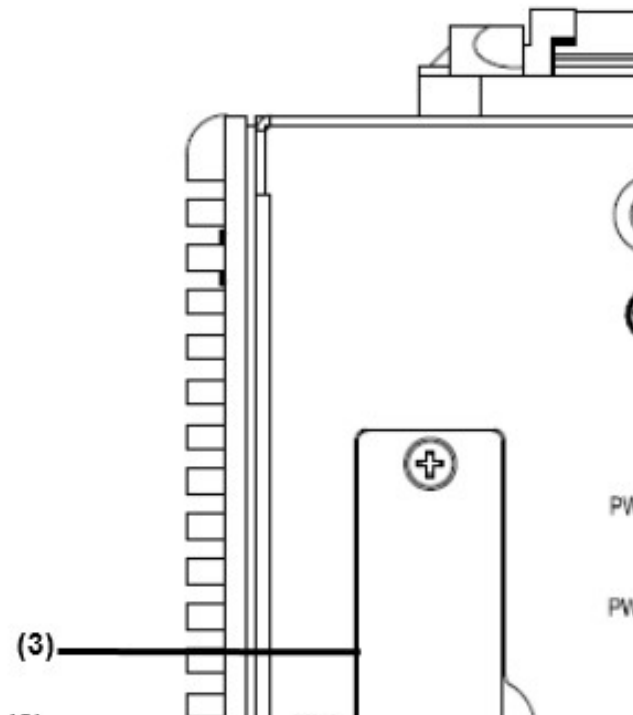

Figure 4 NewPre2100-P521-M1-D0-W3 / NewPre2100-P521-M1-D0-W0 top panel labeling diagram

Table 4 NewPre2100-P521-M1-D0-W3 / NewPre2100-P521-M1-D0-W0 top panel labeling instructions

<b>No.</b>	<b>Identification</b>	<b>Description</b>
(1)	SIM1	SIM card slot 1
(2)	SIM2	SIM card slot 2
(3)	--	Card cover
(4)	CONSOLE	CPU debugging serial interface
(5)	--	Power interface 24V
(6)	--	Grounding screw

### 3 Installation

#### 3.1 Dimension drawing

- 5G Edge General-Purpose Controller NewPre2100-P521-M1-D0-W3 / NewPre2100-P521-M1-D0-W0 (The panel takes NewPre2100-P521-M1-D0-W3 as an example, the same as later)

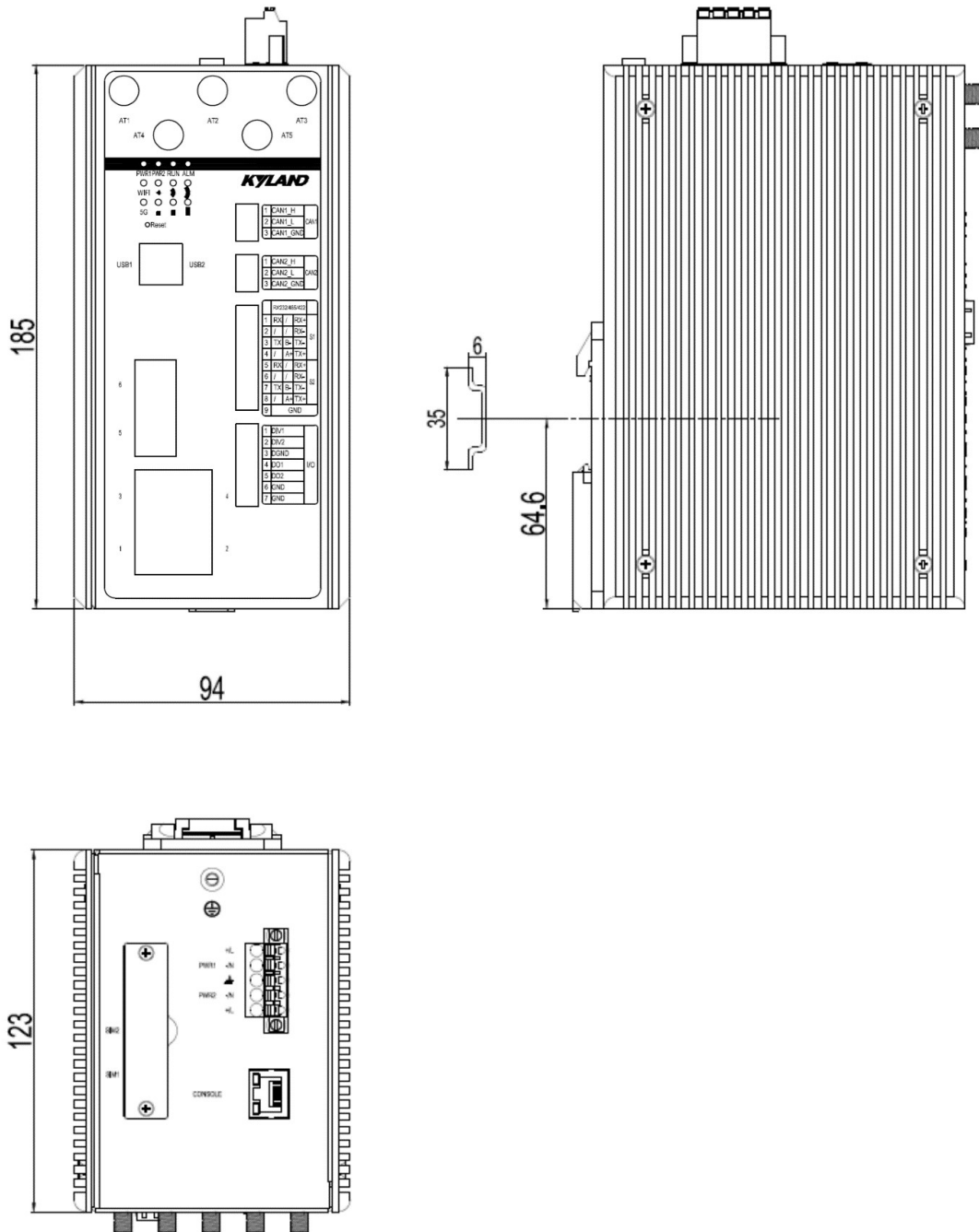

Figure 5 NewPre2100-P521-M1-D0-W3 / NewPre2100-P521-M1-D0-W0 installation dimension drawing (Unit: mm)





**Note:**

- The device casing is part of the whole machine cooling system, the casing will be hot during normal operation, please do not cover the casing when the device is working.
  - The pictures in this manual are schematic drawings. For details, refer to the actual objects.
- 

## **3.2 Installation methods and procedures**

The device can be mounted on rails or walls. Before installing the device, confirm the following installation requirements:

- 1) Environment requirements: Operating temperature  $-40^{\circ}\text{C}$  to  $+75^{\circ}\text{C}$ , storage temperature  $-40^{\circ}\text{C}$  to  $+85^{\circ}\text{C}$ , relative humidity 5% to 95% (no condensation).
- 2) Power requirements: Confirm that the operating voltage matches the voltage range identified on the device.
- 3) Ground resistance requirements:  $<5\Omega$ .
- 4) Avoid direct sunlight, away from heat sources or areas with strong electromagnetic interference.
- 5) The installation environment should meet the requirements of the authority. Do not touch the device directly with your hands to avoid personal injury.
- 6) Only professionals or trained and qualified personnel can install, replace and maintain the device.

### **3.2.1 Clamping rail installation**

- Clamping rail installation

Step 1. Determine the installation position of the device and ensure that the installation space is sufficient and the heat dissipation is smooth.

Step 2: Snap the upper part of the clamping rail base onto the DIN rail, apply slight pressure upward on the lower end of the device, and turn the device according to the arrow 2 pointing in the figure below until the device is reliably mounted onto the DIN rail to complete the installation.

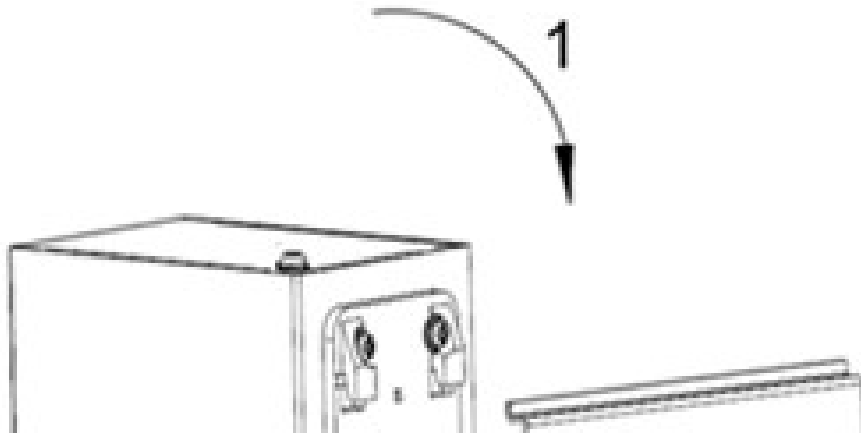

Figure 6 Clamping rail installation diagram

- Clamping rail removal

Step 1. As shown on the left of the following figure, insert the screwdriver head into the hole at the lower part of the spring lock piece, lift the screw handle upward, and open the spring lock piece of the DIN clamping rail base.

Step 2. Turn the device in the direction of arrow 2 in the figure below, turn and lift the device upward in the direction of arrow 3 after the lower end of the device is free from the DIN rail, until the upper end of the DIN clamping rail base is free from the DIN rail to complete the disassembly.

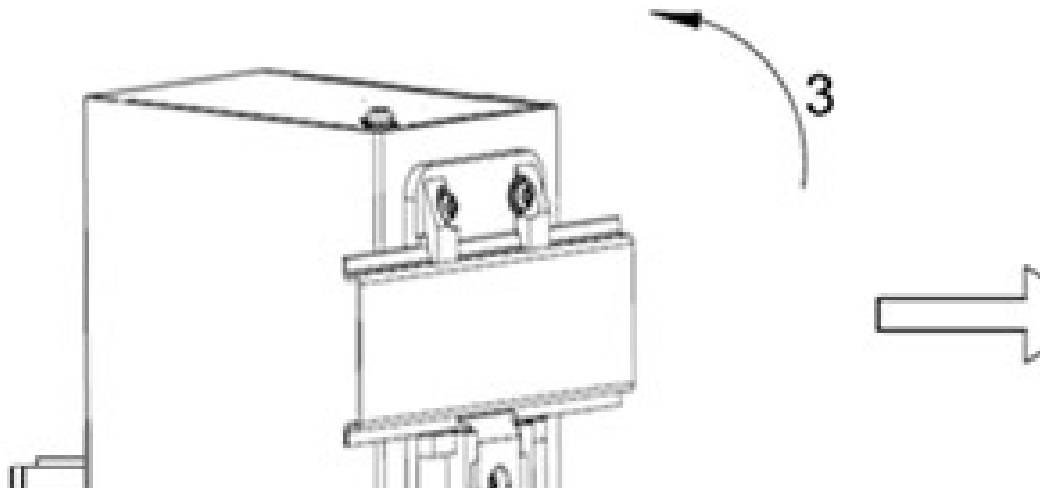

Figure 7 Clamping rail removal diagram

### 3.2.2 Wall-mounted



#### Description:

If wall-mounted installation is required, the user needs to order a wall-mounted plate (optional).

- Wall-mounted

Step 1. Secure the wall-mounted plate to the rear panel of the device using screws according to the screw holes on the rear panel of the device.

Step 2. Determine the installation position of the device (for example, a vertical wall or the inner wall of the cabinet) and ensure that the installation space is sufficient and the heat dissipation is smooth.

Step 3. In the selected location in accordance with the wall-mounted installation size chart to punch four holes, using a Phillips screwdriver to install four screws to the selected location of the four holes, the screws do not completely tighten, retaining a distance of about 5 mm.

Step 4. Align the 4  $\Phi 6.5$  parts on the wall-mounted holes of the appliance with and through the 4 screws already in place and move the appliance as shown below with the arrow 1 pointing to the appliance until the screws enter the  $\Phi 4$  parts of the wall-mounted holes. Finally, fasten the four screws to complete the installation.

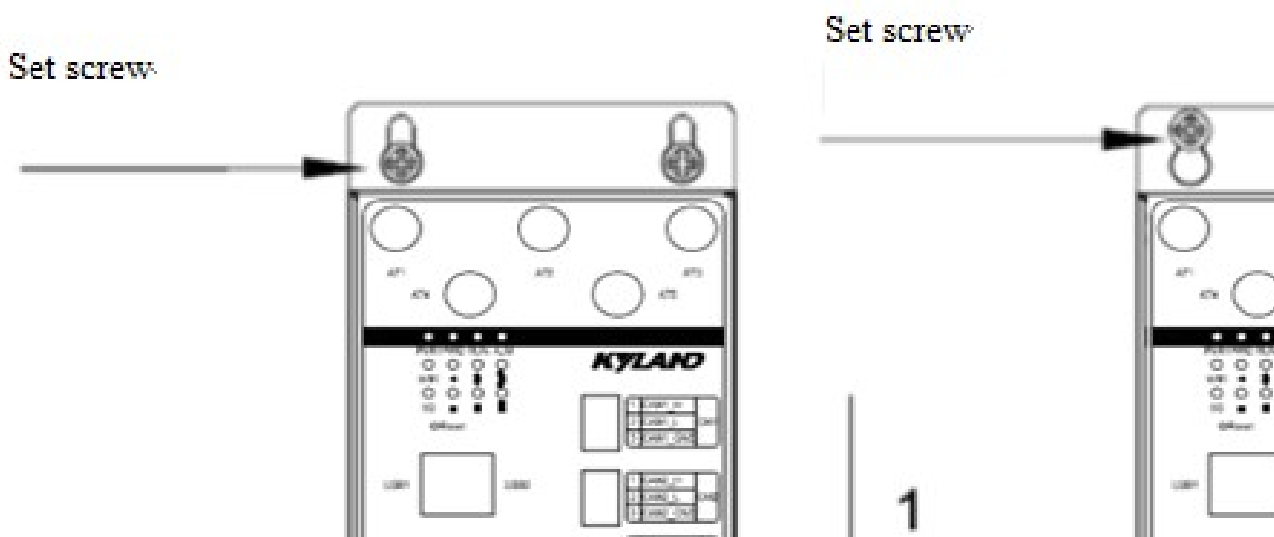

Figure 8 Wall-mounted installation diagram

- Wall-mounted removal

Step 1. Use a screwdriver to loosen the four screws fixed, move the device according to the

arrow 2 pointing to the following figure, until the screws into the  $\Phi 6.5$  part of the device wall-mounted plate hole, and then the wall-mounted hole through the loosened four screws, the device can be detached from the wall or cabinet wall.

Step 2. Remove the screw from the wall or cabinet using a screwdriver, and remove the wall-mounted plate from the rear panel of the device.

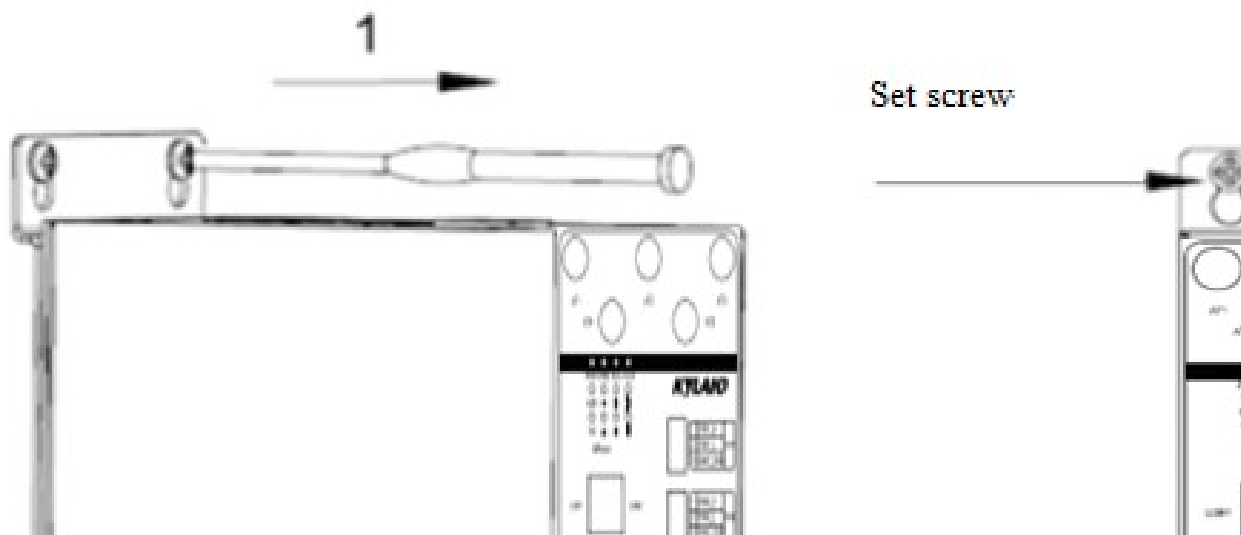

Figure 9 Wall-mounted removal diagram



**Note:**

Before installing, removing, or moving a device, disconnect the power supply and remove all cables.

### 3.2.3 Antenna installation and SIM card installation

- Antenna installation (available only when selecting NewPre2100-P521-M1-D0-W3)

Step 1. Obtain the antenna of the corresponding module.

Step 2. Screw the corresponding module antenna to the corresponding antenna installation interface by rotating clockwise.



**Description:**

ANT1 to ANT4 are the antenna installation interfaces of 5G module; ANT5 is the installation interface for the WIFI module.

- SIM card installation

Step 1. Obtain the SIM card for installation.

Step 2. Remove the screws from the top panel card cover with a screwdriver to expose the SIM card slot.

Step 3. Insert the metal IC part of the SIM card upward into the SIM card slot.

Step 4. Cover the card cover and use a screwdriver to tighten the set screws of the top panel card cover.



**Note:**

Before installing, removing, or moving a device, disconnect the power supply and remove all cables.

---

## 4 Wire

### 4.1 10/100/1000Base-T(X) Ethernet interface

The 10/100/1000Base-T(X) Ethernet interface adopts standard RJ45 connector with adaptive function, which can be automatically configured to 10M/100M/1000M state and full-duplex/half-duplex operation mode, and supports MDI/MDI-X self-identification function of the cable, i.e. it can be connected with terminal device and network device using either direct network cable or crossover network cable.

- Interface definition

RJ45 interface pin numbers are shown in the following figure.

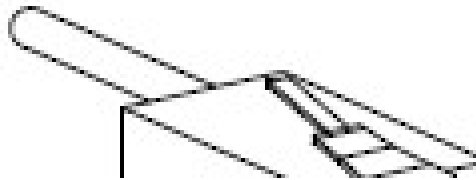

Figure 10 RJ45 interface pin numbers

Table 5 10/100/1000Base-T(X) RJ45 interface pins definition

Pin	MDI-X	MDI
1	Send/receive data (TRD1+)	Send/receive data (TRD0+)
2	Send/receive data (TRD1-)	Send/receive data (TRD0-)
3	Send/receive data (TRD0+)	Send/receive data (TRD1+)
4	Send/receive data (TRD3+)	Send/receive data (TRD2+)
5	Send/receive data (TRD3-)	Send/receive data (TRD2-)
6	Send/receive data (TRD0-)	Send/receive data (TRD1-)
7	Send/receive data (TRD2+)	Send/receive data (TRD3+)
8	Send/receive data (TRD2-)	Send/receive data (TRD3-)

Description:  
 "+" "-" indicate the level polarity.

- Connector line sequence

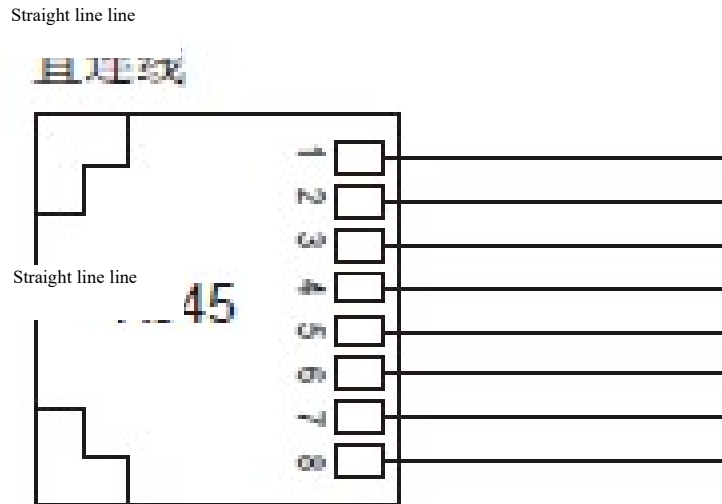

Figure 11 10/100/1000Base-T(X) RJ45 connector direct and cross cable interconnection



**Description:**

RJ45 connectors are wired as standard 568B (1-orange white, 2-orange, 3-green white, 4-blue, 5-blue white, 6-green, 7-brown white, 8-brown).

## 4.2 RS-232/RS-485/RS-422 interface

RS-232/RS-422/RS-485 interface pins are defined as shown in the following figure.

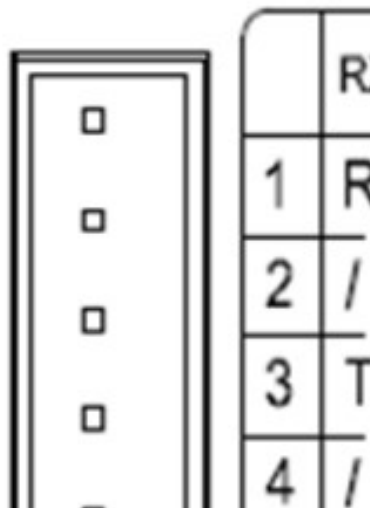

Figure 12 Interface pin definition

Table 6 serial interface pin definition

Pin	RS-232	RS-485	RS-422
1	RX	NA	RX+
2	NA	NA	RX-

3	TX	B-	TX-
4	NA	A+	TX+
5	RX	NA	RX+
6	NA	NA	RX-
7	TX	B-	TX-
8	NA	A+	TX+
9	GND	GND	GND



Description:

Pins 1-4 are way 1, and pins 5-8 are way 2.

### 4.3 USB connector

The USB interface is located on the front panel of the device and contains two USB3.0 interfaces, both of which use standard A female ports. USB interface pins are defined as shown in the figure below.

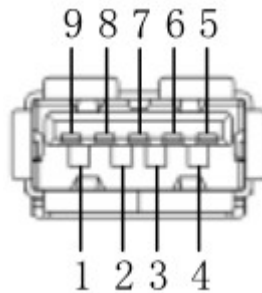

Figure 13 USB3.0 interface pin numbers

Table 7 USB3.0 interface pin definitions

USB pin	Definition	USB pin	Definition
1	VBUS	2	D-
3	D+	4	GND
5	SSRX-	6	SSRX+
7	GND	8	SSTX-
9	SSTX+		

### 4.4 CAN interface

2-way CAN interfaces (CAN1 and CAN2) pins are defined as shown in the figure below.



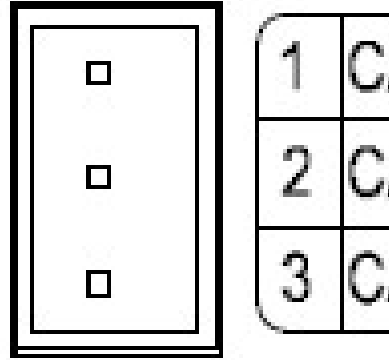

Figure 14 CAN interface diagram

Table 8 CAN pin definition

CAN1	Definition	CAN2	Definition
1	CAN1_H	1	CAN2_H
2	CAN1_L	2	CAN2_L
3	CAN1_GND	4	CAN2_GND

## 4.5 DI/DO interface

The following figure shows the pin definition of 4-way DI/DO interfaces (2-way DI/DO interfaces).

(available only when selecting NewPre2100-P521-M1-D0-W3)

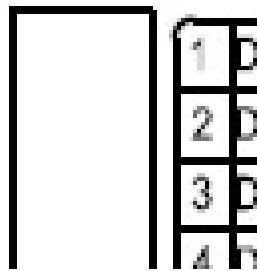

Figure 15 AI/DI/DO wiring terminal interface diagram

Table 9 DI/DO pin definitions

DI/DO pin	Definition	DI/DO pin	Definition
1	DIV1	2	DIV2
3	DGND	4	DO1
5	DO2	6	GND
7	GND		

## 4.6 Console interface

- RJ45 Management interface

Connect the 9-pin serial interface of the PC to the Console interface of the device using a DB9-RJ45 network cable. Run the HyperTerminal software of WINDOWS system to call the console software of the device to realize the configuration, maintenance, and management functions of the device.

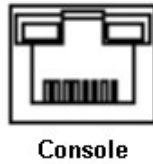

Figure 16 Console interface

- DB9-RJ45 network pipeline

One end of the DB9-RJ45 network pipeline is a DB9 plug, which needs to be plugged into the 9-pin serial interface of the PC, and the other end is a crimped RJ45 connector, which needs to be plugged into the Console interface of the device.

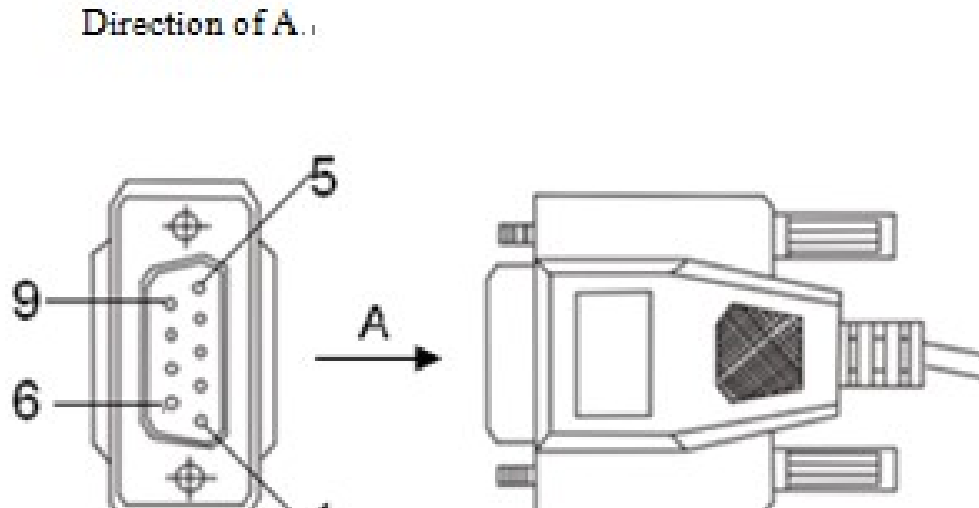

Figure 17 DB9-RJ45 network pipeline sequence

Table 10 DB9 interface (9-pin serial interface on PC) and RJ45 interface (Console interface) pin definitions

DB9 interface (9-pin serial interface on PC)		RJ45 interface (Console interface)	
Pin	Signal	Pin	Signal
2	RXD (Receive data)	2	TXD (Send data)

3	TXD (Send data)	3	RXD (Receive data)
5	GND (Grounding)	5	GND (Grounding)

## 4.7 Grounding

The device is properly grounded to protect the device from lightning and interference. Therefore, you must properly connect the grounding screw. Ground the device before powering on, and disconnect the grounding screw after powering off the device.

There is a ground screw on the cover plate of the device, that is, the grounding screw of the housing, which is called the "casing ground". One end of the grounding screw is crimped to the cold crimp terminal and fixed with grounding screw at the "casing ground", and the other end of the grounding screw is reliably connected to the earth.



### Description:

Grounding screw cross-sectional area of 2.5mm<sup>2</sup> or more; grounding resistance requirements: <5.

## 4.8 Power supply terminal

The power supply terminal is located on the upper cover of the device and connects to the power cable to supply power to the device. This series of device supports redundant power input, using 5-core 5.08mm spacing plug out wiring terminals, when any of the power supply fails, the device can operate normally without interruption, improving the reliability of network operation.



### Description:

- Power cord cross-sectional area of 0.75 mm<sup>2</sup> or more (wiring maximum cross-sectional area of 2.5 mm<sup>2</sup>); grounding resistance requirements: <5Ω.
- Copper conductors must be used for onsite cable connections, and the temperature must meet 75 ° C.

- 5-core 5.08mm spacing plug out wiring terminals

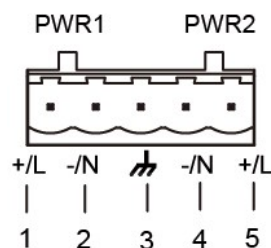



Figure 18 5-core 5.08mm spacing plug out wiring terminals (socket)

Table 11 5-core 5.08mm spacing plug out wiring terminals definition

Terminal number	Signal name	DC wire definition	AC wire definition
1	+/L	PWR1: +	PWR1: L
2	-/N	PWR1: -	PWR1: N
3		PGND protected ground	PGND protected ground
4	-/N	PWR2: -	PWR2: N
5	+/L	PWR2: +	PWR2: L

● Wire and installation

Step 1. Properly ground the device according to the grounding procedure.

Step 2. Remove the power supply terminal plug from the device.

Step 3. Insert one end of the power cord into the power supply terminal plug and secure the power cord according to Table 11.

Step 4. Plug the connected power cord back into the corresponding power supply terminal socket of the device.

Step 5. Connect the other end of the power cable to the corresponding external power supply system according to the power supply requirements marked on the device. Check whether the corresponding power indicator of the device is on.

Wire and installation should meet the following specifications.

Table 12 Wire and installation specifications

Classification of terminal	Torque requirements	Wire cross-sectional area (AWG)
Plug out terminals	4.5-5.0 lb-in	12-24



**Note:**

Before connecting to the power supply, please confirm that the power supply matches the power supply requirements marked on the device to avoid damage to the device.

---



**Warning:**

- Do not touch any exposed wires, terminals and dangerous voltage marks marked on the product to avoid injury to human body.
  - Do not disassemble components or plug and unplug connectors during the powering on process
-

## 5 Reset

The Reset button is located on the front panel of the device and has the function of rebooting and restoring the default configuration. Press the reset button for 0.5~3 seconds and then release it to complete the device restart. Keep pressing the reset button for more than 3 seconds and release it to restore the default configuration and restart.

---



**Note:**

If you want to reboot the device, be careful not to press the reset button for more than 3 seconds to prevent the device from reverting to its default configuration.

---

## 6 LED Indicator State

Table 13 Description of indicators on the front panel

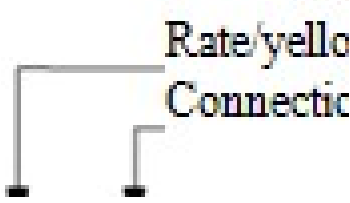
LED	State	Description
Power indicator 1 (green)	On	The input power supply 1 is connected and running properly
	Off	The input power supply 1 is disconnected or runs abnormally
Power indicator 2 (green)	On	The input power supply 2 is connected and running properly
	Off	The input power supply 2 is disconnected or runs abnormally
Running indicator (green)	Sparkle bright	The motherboard CPU is running normally
	Steady on	The device is being powered on and started. Procedure
	Off	The motherboard CPU does not start or runs in an abnormal state
Alarm indicator (green)	On	System alarm display
	Off	No system alarm display
		
10/100/1000Base-T(X) Ethernet interface rate indicator (yellow)	On	1000M working state (1000Base-TX)
	Off	10/100M working state (10/100Base-T(X) or no connection)
10/100/1000Base-T(X) Ethernet interface connection state indicator (green)	On	The interface has a valid network connection
	Sparkle bright	The interface has network activity
	Off	The interface doesn't have a valid network connection
WIFI intensity indicator (green) (available only when selecting NewPre2100-P521-M1-D0-W3)	On	The <b>WIFI</b> signal reaches the intensity
	Off	The <b>WIFI</b> signal does not reach the intensity
5G intensity indicator (green) (available only when selecting NewPre2100-P521-M1-D0-W3)	On	The <b>5G</b> signal reaches the intensity
	Off	The <b>5G</b> signal does not reach the intensity

## 7 Basic Performance and Specifications

<b>Power supply</b>		
Power supply identification	Input rated voltage range	Input maximum voltage range
L2	24VDC	18-72VDC
Access terminal	5-core 5.08mm spacing plug out wiring terminals	
<b>Nominal power</b>		
Nominal power	<25W	
<b>Mechanical structure</b>		
Casing	All-metal unibody, fanless	
Degree of protection	IP40	
Installation method	DIN clamping rail installation, wall-mounted installation	
Dimension (W×H×D)	94mm x 185mm x 123mm (excluding connector protruding, DIN clamping rail and wall-mounted assembly dimensions)	
Weight	2.23KG	
<b>Environment</b>		
Operating temperature	-40°C~+75°C	
Storage temperature	-40°C~+85°C	
Relative Humidity:	5% to 95% condensation free	
<b>Warranty period</b>		
Warranty period	2 years	