

# Table of Contents

---

Disclaimers.....	ii
Safety Precautions.....	iii
Classifications.....	iv
General Cleaning Tips .....	v
Scrap Computer Recycling.....	vi
<b>SECTION 1 INTRODUCTION.....</b>	<b>1</b>
1.1    General Descriptions .....	1
1.2    System Specifications .....	2
1.2.1    CPU .....	2
1.2.2    I/O System .....	2
1.2.3    System Specifications.....	3
1.2.4    Driver CD Contents.....	4
1.3    Dimensions .....	5
1.3.1    System Dimensions.....	5
1.3.2    Wall-mount Bracket Dimensions .....	6
1.3.3    Din-Rail Bracket Dimensions.....	8
1.3.4    VESA Mount Bracket Dimensions .....	10
1.4    I/O Outlets.....	12
1.5    Packing List.....	14
1.6    Model List .....	14
<b>SECTION 2 HARDWARE INSTALLATION .....</b>	<b>15</b>
2.1    Installation of 2.5" SATA Device.....	15
2.2    Installation of Memory Module.....	16
2.3    Installation of M.2 Mini PCIe Module (CN18) .....	18
2.4    Installation of Mini PCIe Module (Full-size)(CN16).....	19
<b>SECTION 3 JUMPER &amp; CONNECTOR SETTINGS.....</b>	<b>21</b>
3.1    Locations of Jumpers & Connectors.....	21
3.2    Summary of Jumper Settings.....	23
3.2.1    Restore BIOS Optimal Defaults (JP1) .....	23
3.3    Connectors.....	24
3.3.1    DC-in Phoenix Power Connector (CN1).....	25
3.3.2    HDMI Connector (CN22) .....	25
3.3.3    VGA Connector (CN28) .....	26
3.3.4    Serial Port Connector (CN27, CN13, CN15).....	26
3.3.5    USB 3.2 Connector (CN24, CN25) .....	27
3.3.6    Ethernet Connector (CN29, CN21) .....	28
3.3.7    ATX Power On/Off (SW1) .....	29
3.3.8    Remote Power Switch Connector (PWRBT1) .....	29
3.3.9    ATX/AT Quick Switch (SSW1).....	29
3.3.10    SATA Power Connector (CN7) .....	29
3.3.11    SATA Connector (CN10) .....	30
3.3.12    Nano SIM Card Slot (CN14) .....	30
3.3.13    Full-Size PCI Express Mini Card Slot (CN16) .....	31
3.3.14    M.2 2230 Key E slot (CN18) .....	32
3.3.15    Intel® HD Audio Digital Header (CN26).....	33
<b>SECTION 4 BIOS SETUP UTILITY .....</b>	<b>35</b>
4.1    Starting .....	35

<b>4.2</b>	<b>Navigation Keys.....</b>	<b>35</b>
<b>4.3</b>	<b>Main Menu.....</b>	<b>36</b>
<b>4.4</b>	<b>Advanced Menu .....</b>	<b>37</b>
<b>4.5</b>	<b>Chipset Menu .....</b>	<b>49</b>
<b>4.6</b>	<b>Boot Menu.....</b>	<b>55</b>
<b>4.7</b>	<b>Save &amp; Exit Menu.....</b>	<b>56</b>

# SECTION 1 INTRODUCTION



This section contains general information and detailed specifications of the .Section 1 consist of the following sub-sections:

- General Descriptions
- System Specifications
- Dimensions
- I/O Outlets
- Packing List
- Model List

## 1.1 General Descriptions

The is a compact embedded system that featuring Intel® Celeron® Processor J6412 (Elkhart Lake) onboard for High performance/low power consumption. It features fan-less design with multiple I/O including 6 USB ports, 3 COM ports, dual Intel® LAN ports and two independent displays. Suitable for the most IoT Gateway, Control system, Edge Computing, and intelligent factory applications.

### Features

- Intel® Elkhart Lake Celeron® J6412 quad-core SoC onboard
- 1 HDMI and 1 VGA for dual view
- Trusted Platform Module (TPM) 2.0 onboard
- Rugged -10 °C to +60°C wide range operation temperature
- Wide range power input 9-36VDC
- M.2 Key E for WiFi/WiFi 6 connection

### Reliable and Stable Design

The embedded system supports Intel® Celeron® Processor J6412 (Elkhart Lake), along with high flexibility and multi-functional design that makes it the best solution for smart factory, AIOT, Edge Computing, Factory automation applications.

### Flexible Connectivity

The comes with rich I/O interfaces including one RS-232/422/485 ports, two RS-232, four USB 3.1 ports, two USB 2.0 ports, one GbE port, one 2.5GbE port, one HDMI(lockable), one VGA, one mPCIe expansion slot and one M.2 key E.

### Embedded O.S. Supported

The supports Windows® 10, Windows® 10 IoT and various Linux versions.

### Various Storage Supported

In terms of storage, the supports one 2.5" SATA storage drive bay and one mSATA devices.

## 1.2 System Specifications

### 1.2.1 CPU

- **CPU**
  - Intel® Celeron® J6412 (Elkhart Lake), up to 10W
- **BIOS**
  - American Megatrends Inc. UEFI (Unified Extensible Firmware Interface) BIOS.
- **System Memory**
  - 1 x 260-pin DDR4-3200 SO-DIMM, up to 32GB

### 1.2.2 I/O System

- **Display**
  - 1 x VGA (Resolution: 1920x1080@60Hz)
  - 1 x HDMI 1.4b (Resolution: 3840x2160@30Hz)
- **Ethernet**
  - 1 x 10/100/1000/2500 Mbps Ethernet supports Wake-on-LAN, UEFI PXE with i226-LM
  - 1 x 10/100/1000 Mbps Ethernet supports Wake-on-LAN, UEFI PXE with Intel i210-AT
- **USB Ports**
  - 4 x USB 3.1 Gen2
  - 2 x USB 2.0
- **Serial Ports**
  - 2 x RS-232 (COM 2, COM3)
  - 1 x RS-232/422/485 (COM1)
- **Digital IO**
  - 1 x optional 8-CH DIO by MOQ50 (default : 4in/4out)  
*\*must remove COM 3 to add 8-CH DIO\**

- **Mini PCIe Interface**
  - 1 x full size internal PCI Express Mini Card slot (mSATA/SIM) (USB + PCIE + SATA)
  - 1 x M.2 2230 E Key (PCIE + USB signal)
- **Storage**
  - 1 x 2.5" SATA HDD/SSD drive bay, up to 9.5mm height
  - 1 x mSATA for mPCIe slot (enable in BIOS setting)
- **Indicator**
  - 1 x Green LED as indicator for PWR status
  - 1 x Orange LED as indicator for HDD active
- **Switch**
  - 1 x ATX PWR switch
  - 1 x Remote power switch
  - 1 x ATX/AT Quick switch
- **Antenna & SIM**
  - 4 x SMA type connector openings for antenna
  - 1 x SIM slot
- **TPM 2.0**
  - 1 x ST33HTPH2E32AHA6
- **Audio**
  - 1 x Line-out

### 1.2.3 System Specifications

- **Watchdog Timer**
  - 1~255 seconds or minutes; up to 255 levels.
- **Power Supply**
  - 9-36V DC input (Typical : 12V/24VDC)
- **Operation Temperature**
  - -10°C to +60°C (+14°F to +140°F) (with W.T. DRAM & SSD)
- **Storage Temperature**
  - -40°C ~+80°C (-40 °F ~ 176°F)
- **Humidity**
  - 10% ~ 95% (non-condensation)
- **Shock**
  - IEC 60068-2-27 (w/SSD: 50G@wall mount, half sine,11 ms duration)
- **Vibration Endurance**
  - IEC 60068-2-64 (w/SSD: 3Grms STD, random, 5 - 500 Hz,1 hr/axis)
- **Weight**
  - 1.2 kg (1.43 lb) without package
  - 1.8 kg (3.97 lb) with package
- **Dimension**
  - 200 mm (7.87") (W) x 120 mm (4.72") (D) x 46 mm (1.81") (H)



## 1.3 Dimensions

The following diagrams show dimensions and outlines of the .

### 1.3.1 System Dimensions

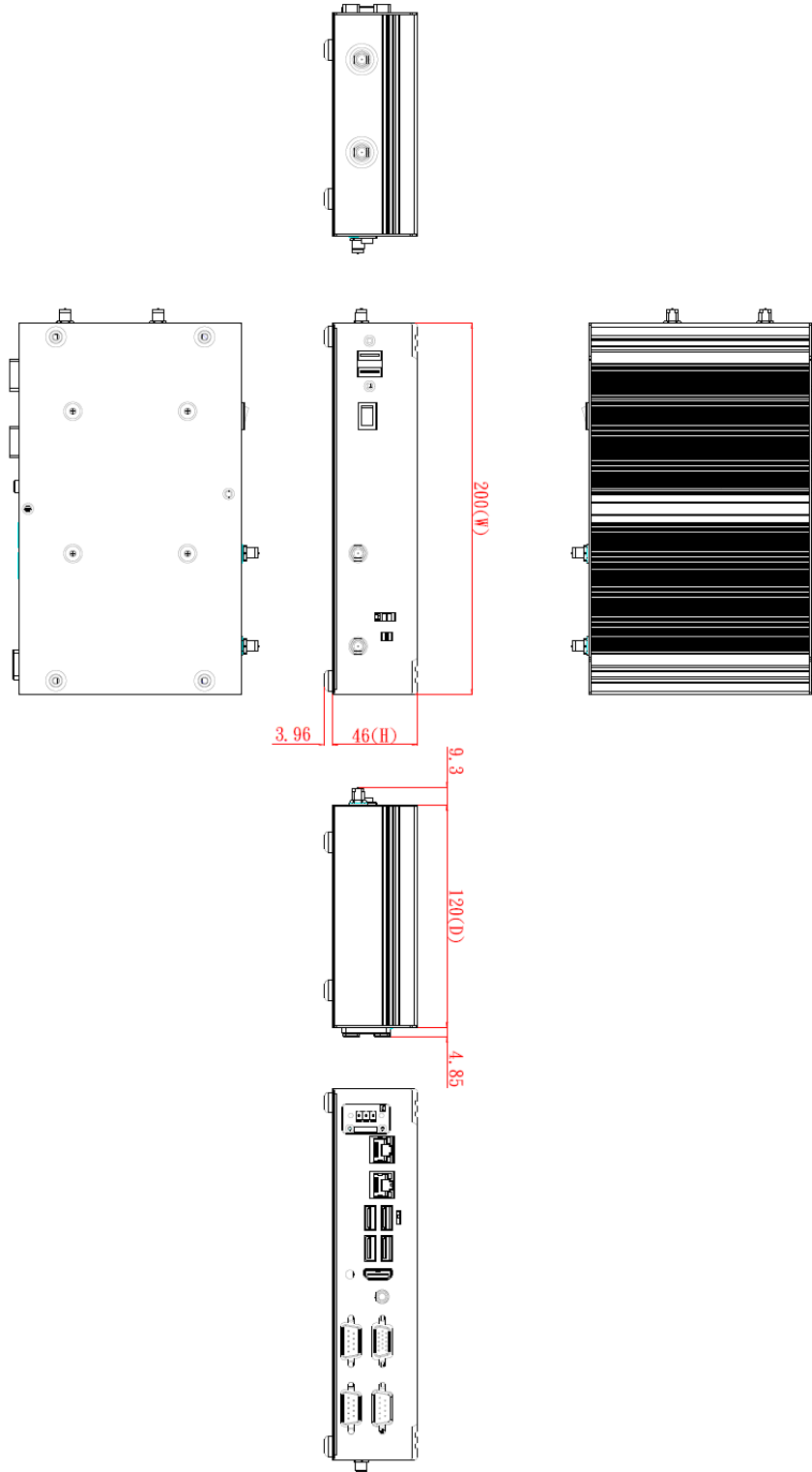

### 1.3.2 Wall-mount Bracket Dimensions

Users can get 4pcs truss head M3\*6L screws for fixing the wall mount kit from the accessories box.

Note: When users install wall mount kit, please turn the LAN ports outlet side towards the floor.

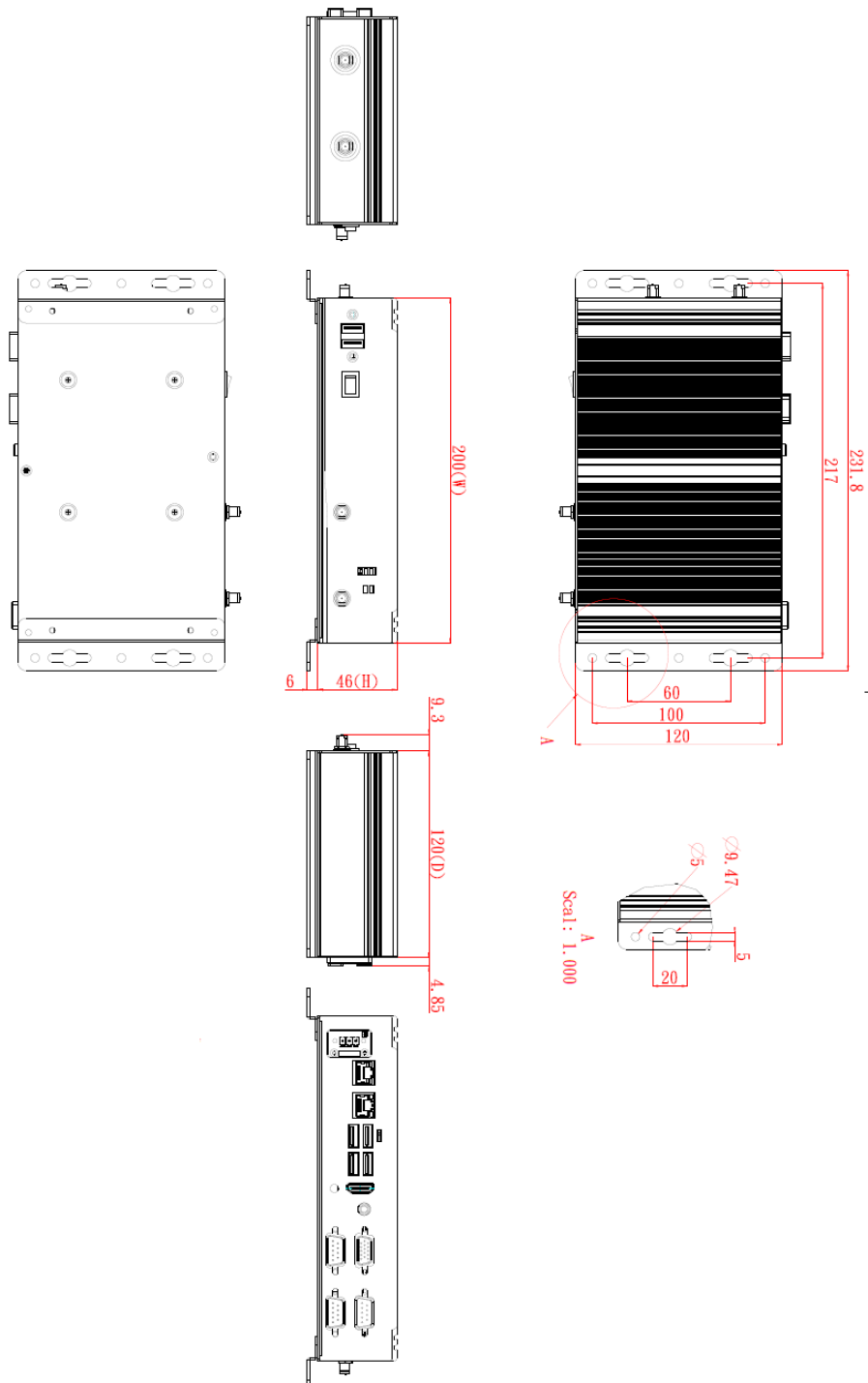



## Wall-mount Bracket Assembly Drawing

Users can get 4pcs truss head M3\*6L screws for fixing the wall mount kit from the accessories box.

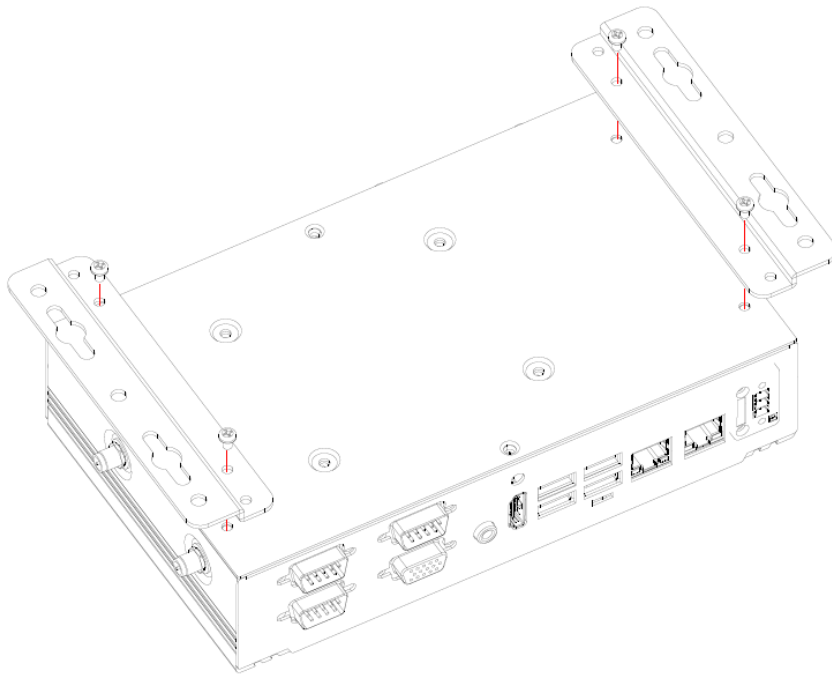

**【Note】** : *If users tighten the screws in drywall, use the hollow wall anchors to ensure that unit does not pull away from the wall due to prolonged strain between the cable and power connector.*

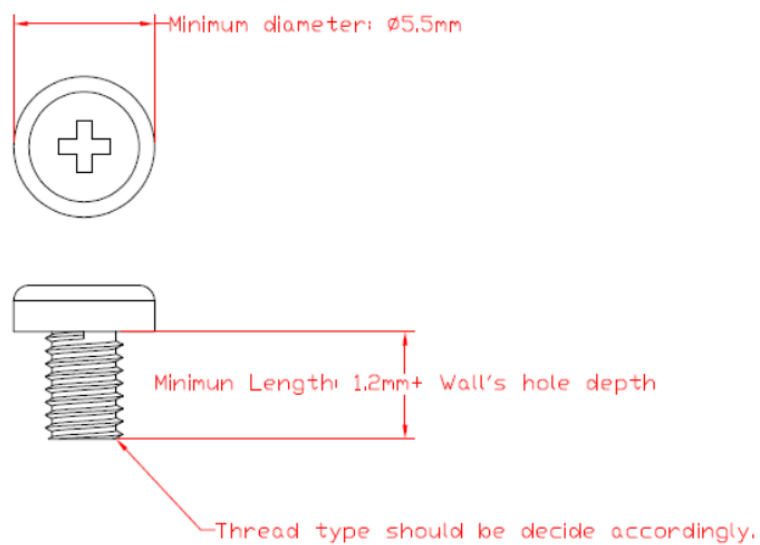

### 1.3.3 Din-Rail Bracket Dimensions

Users can get 8pcs truss head M3\*4L screws for fixing the wall mount kit from the accessory box.

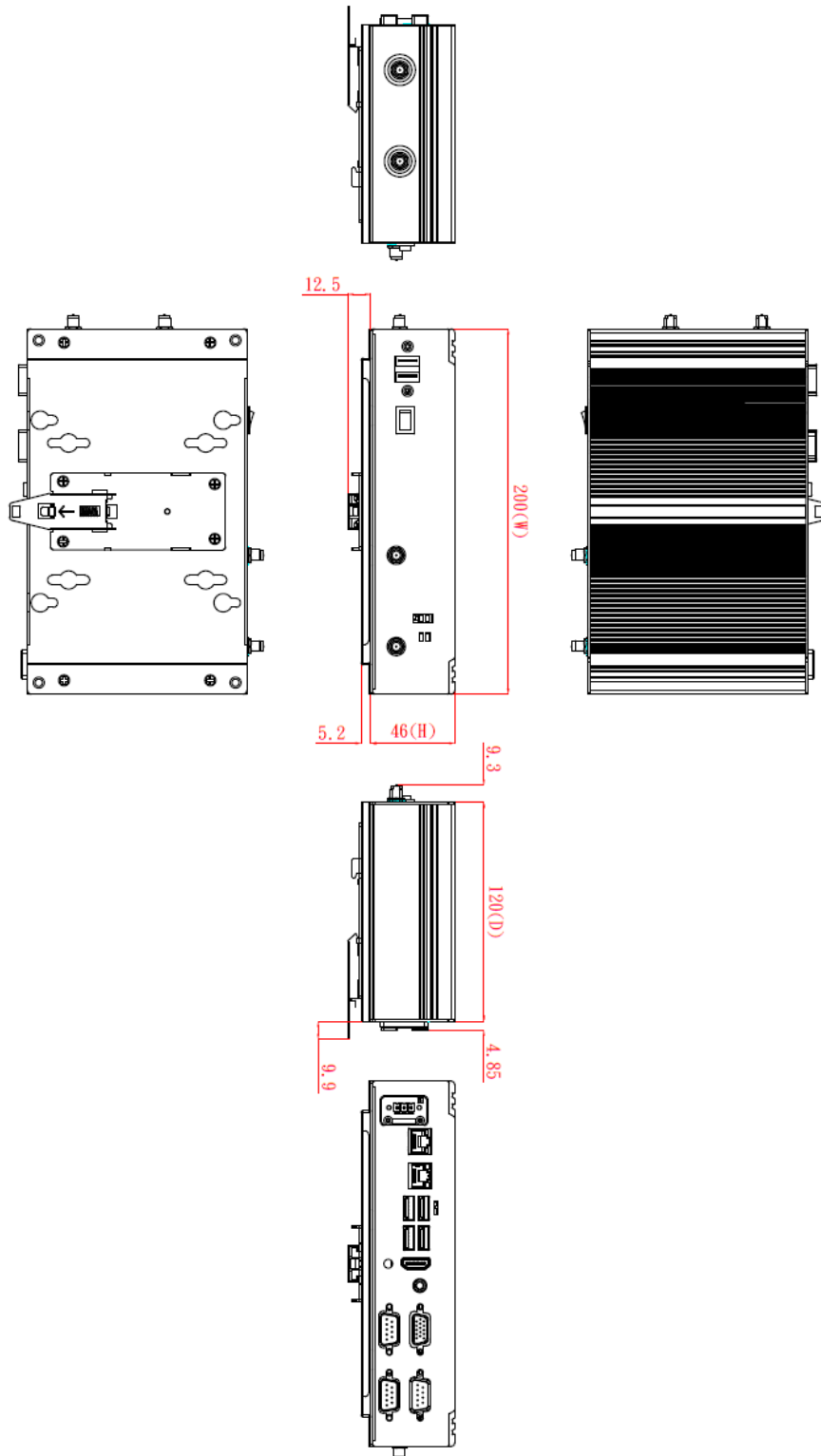

## Din-Rail Bracket Assembly Drawing

Users can get 8pcs truss head M3\*4L screws for fixing the wall mount kit from the accessory box.

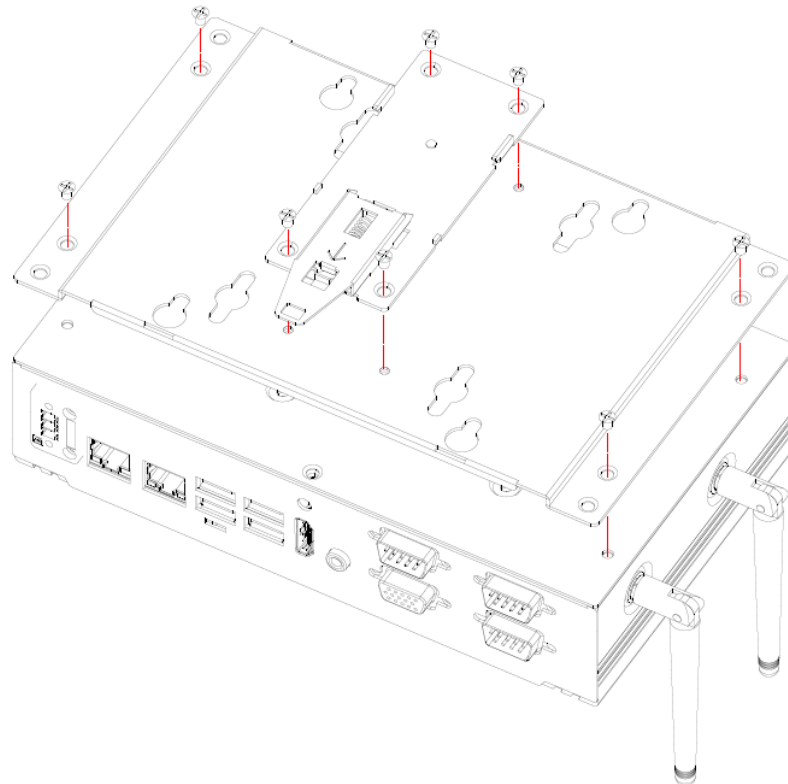

### 1.3.4 VESA Mount Bracket Dimensions

Users can get 4pcs truss head M3\*6L screws for fixing the wall mount kit from the accessory box.

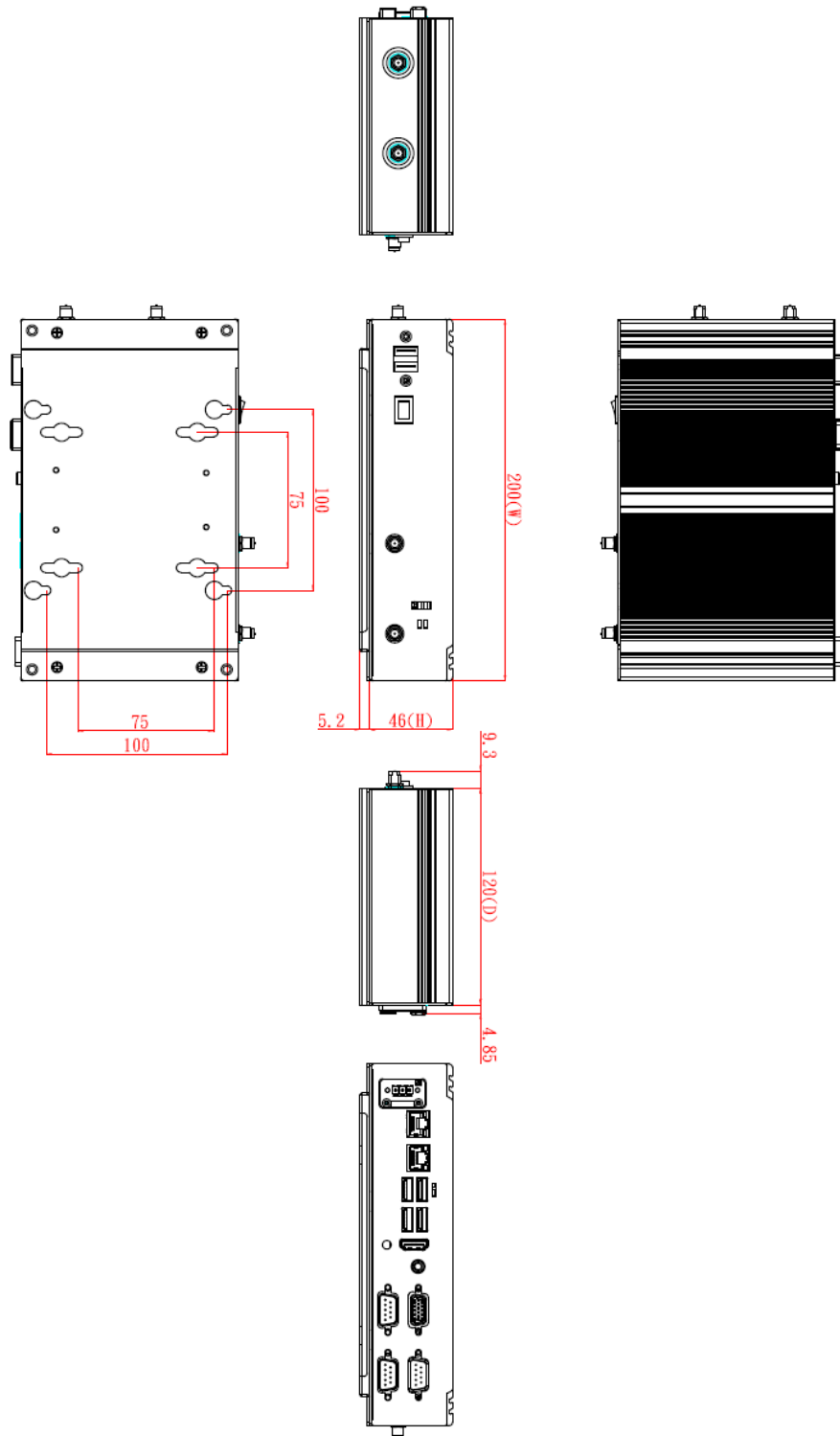

## VESA Mount Bracket Assembly Drawing

Users can get 4pcs truss head M3\*6L screws for fixing the wall mount kit from the accessory box.

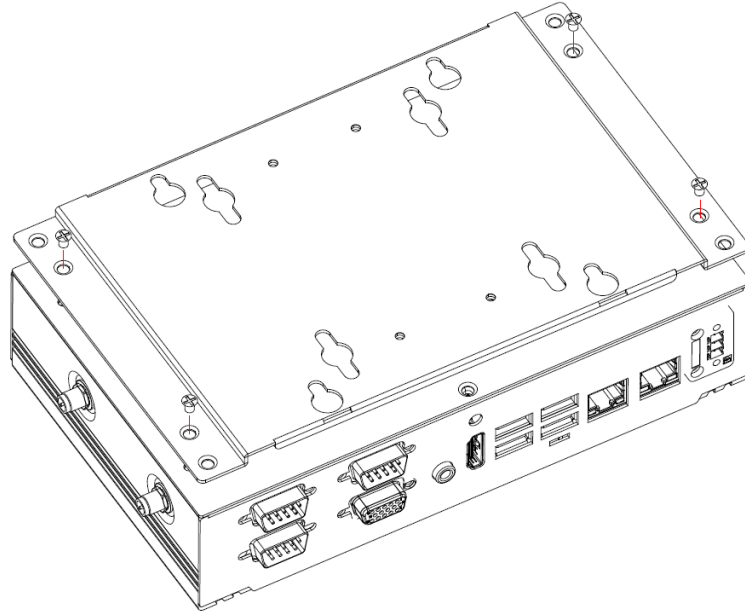

## 1.4 I/O Outlets

The following figures show I/O outlets on the .

### Front View

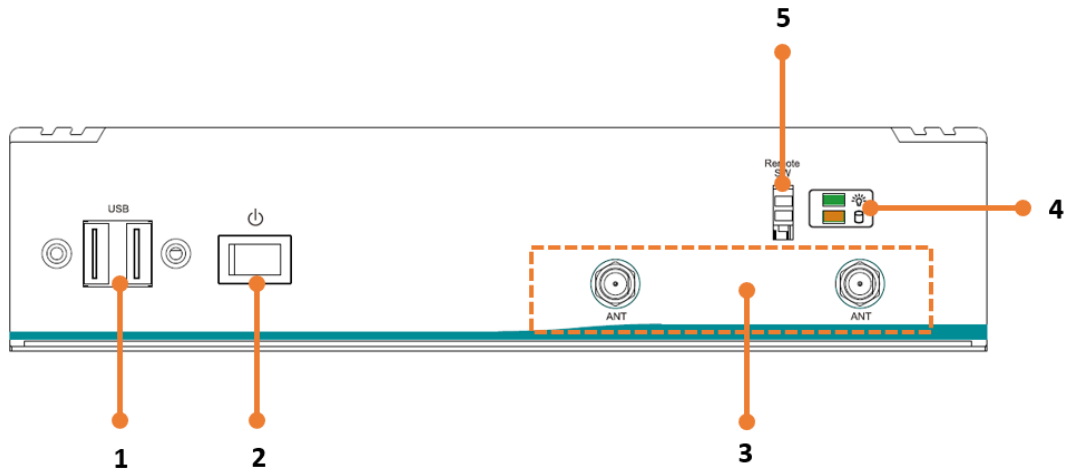

1	2 x USB 2.0	2	1 x Power button
3	2 x Antenna opening	4	LEDs
5	1 x Remote power switch		

## Rear View

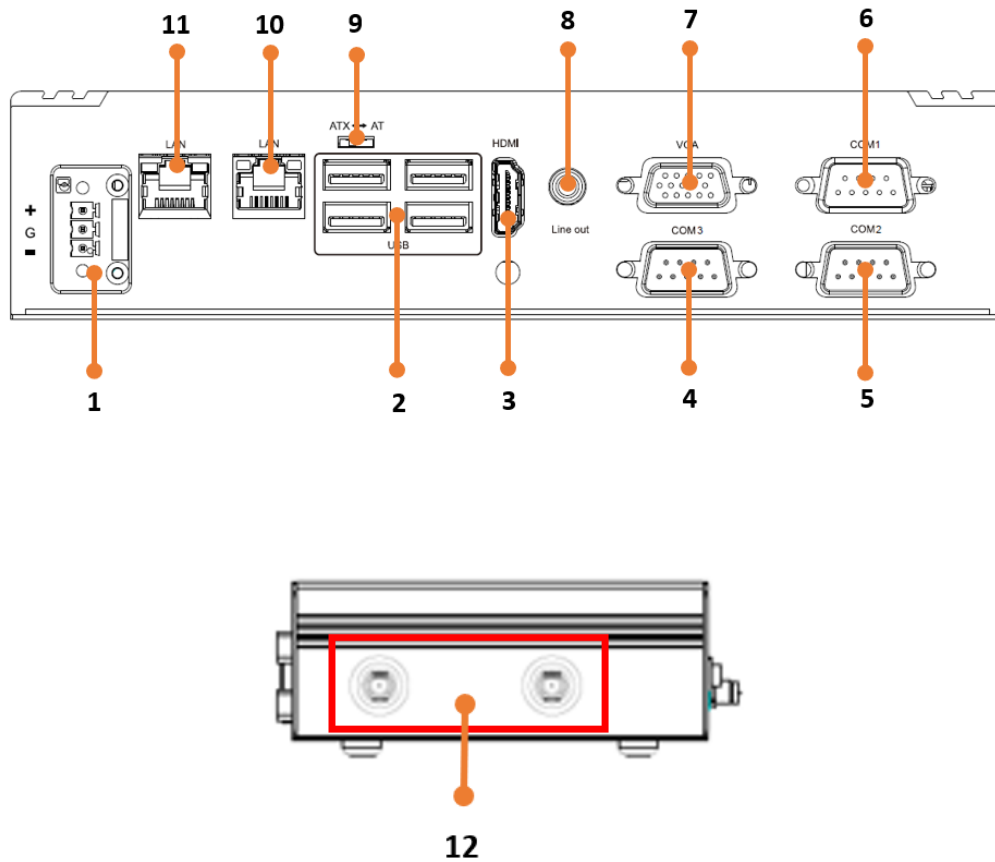

1	1 x Phoenix type power connector(9-36VDC)	7	1 x VGA
2	4 x USB 3.1 Gen 2	8	1 x Audio (Line-out)
3	1 x HDMI 1.4b (lockable)	9	1 x ATX/AT quick switch
4	1 x RS232 (COM3)	10	1 x 2.5G LAN (LAN 1, i226-LM)
5	1 x RS232 (COM2)	11	1 x GbE LAN (LAN 2, i210-AT)
6	1 x RS232/422-485 (COM1)	12	2 x Antenna opening

## 1.5 Packing List

The \_\_\_\_\_ comes with the following bundle package:

- **System Unit x 1**
- **3-pin Terminal Block connector x 1**
- **Remote Switch Cable x 1**
- **Pre-installed Foot Pad x 4**
- **DRAM thermal pad x 3**
- **DRAM thermal pad bracket x1**

## 1.6 Model List

	Fanless Embedded System with Intel® Elkhart Lake J6412 2.0 GHz, HDMI/VGA, 6 USB, 2 LAN, 3 COM, and 9 to 36 VDC
--	--



---

## SECTION 2 HARDWARE INSTALLATION

The is convenient for various hardware configurations, such as DRAM, HDD (Hard Disk Drive), SSD (Solid State Drive), PCI Express Mini card, M.2 module. Section 2 contains guidelines for hardware installation.

### 2.1 Installation of 2.5" SATA Device

**Step 1** Turn off the system and unplug the power cord.

**Step 2** Turn the system upside down to locate screws at the side of the system, and then loosen two screws and four foot pads.

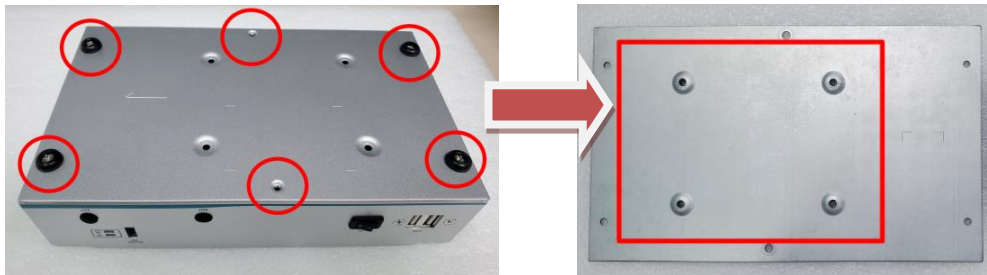

**Step 3** Assemble SSD/HDD with the bottom cover with 4 screws.

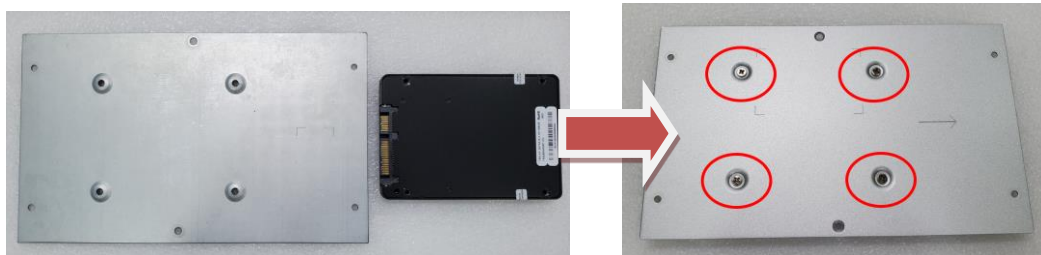

**Step 4** Connect the power and SATA cable directly and then make sure the insertion is complete.

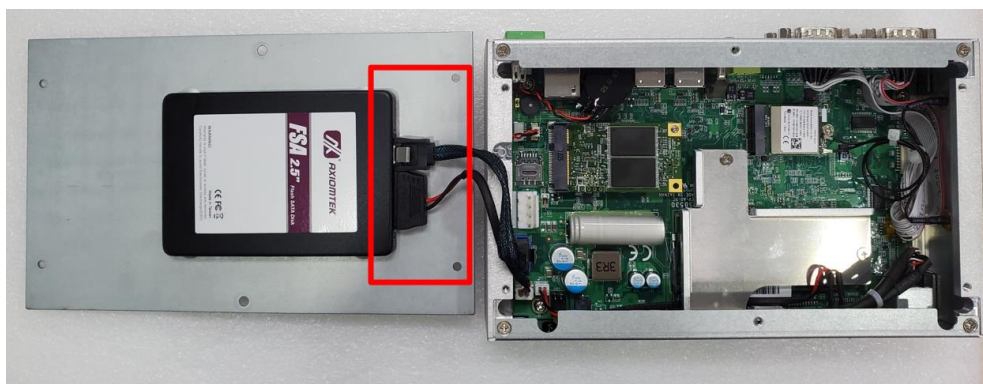

**Step 5** Put the bottom cover back.

## 2.2 Installation of Memory Module

**Step 1** Turn off the system and unplug the power cord.

**Step 2** Turn the system upside down to locate screws at the side of the system, and then loosen two screws and four-foot pads.

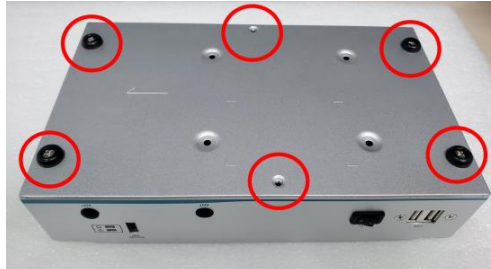

**Step 3** prepare the DRAM bracket, thermal pads, screws, and locate the DDR4 SO-DIMM slot as red marked and put the thermal pad on the DRAM module and DRAM socket.

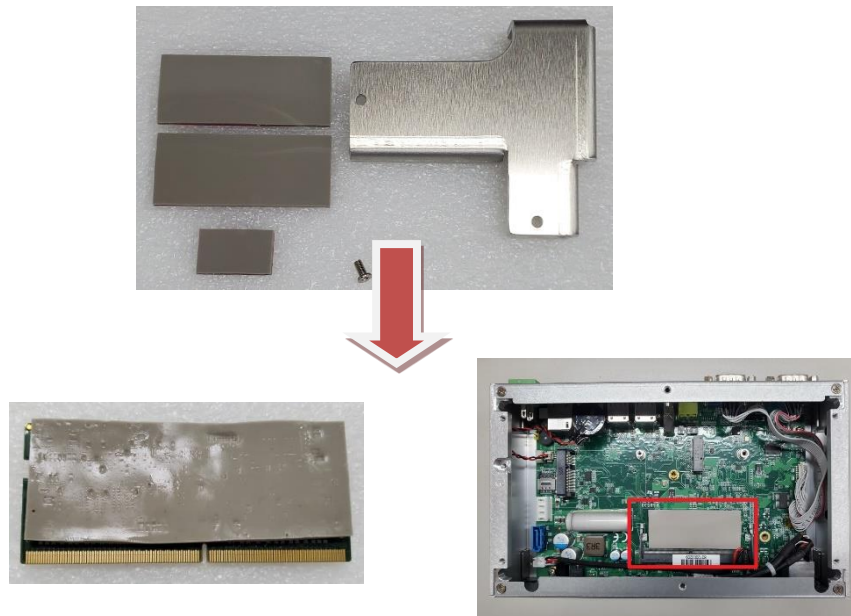

**Step 4** Insert the SO-DIMM into the socket and push the module down until it is locked in place by the two end latches.



**Step 5** Secure the DRAM bracket on top of the DRAM module with two screws. Please note screw 1 first then screw 2.

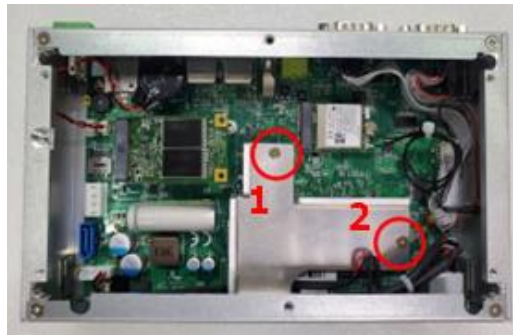

## 2.3 Installation of M.2 Mini PCIe Module (CN18)

**Step 1** Turn off the system and unplug the power cord.

**Step 2** Turn the system upside down to locate screws at the side of the system, and then loosen two screws and four foot pads.

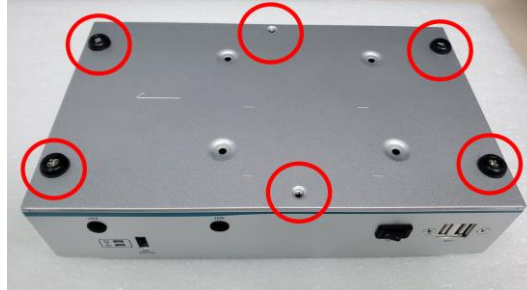

**Step 3** Located the M.2 bracket as red marked, insert the M.2 mini card and tighten the screw.

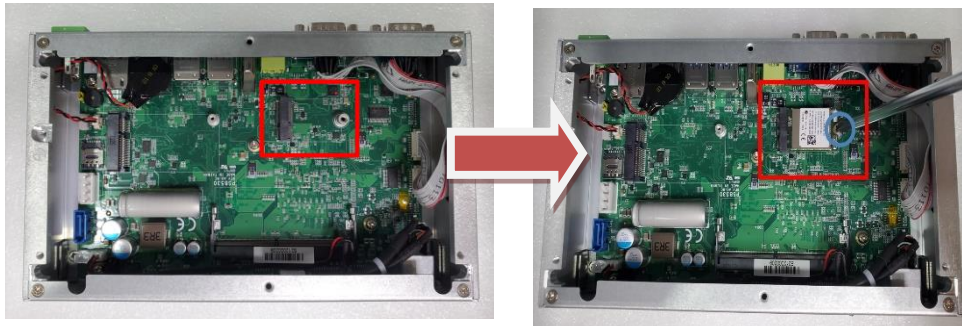

**Step 4** Put the bottom cover and tighten all screws back onto the system.

## 2.4 Installation of Mini PCIe Module (Full-size)(CN16)

※ *Note: Please choose Mini card module or mSATA module either one to install.*

**Step 1** Turn off the system and unplug the power cord.

**Step 2** Turn the system upside down to locate screws at the side of the system, and then loosen two screws and four foot pads.

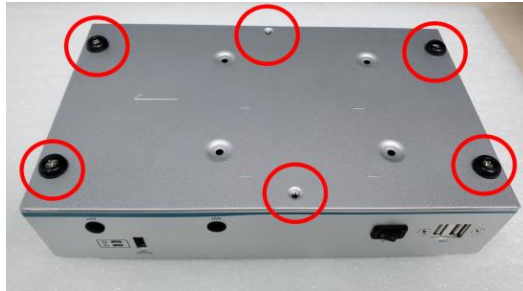

**Step 3** Insert a mini PCIe module into the sockets and then tighten the screw.



**Step 4** Put the bottom cover and tighten all screws back onto the system.

**This page is intentionally left blank.**

# SECTION 3 JUMPER & CONNECTOR SETTINGS

Proper jumper settings configure the \_\_\_\_\_ to meet various application needs. Hereby all jumpers settings along with their default settings are listed for devices onboard.

## 3.1 Locations of Jumpers & Connectors

PSB530 Top View

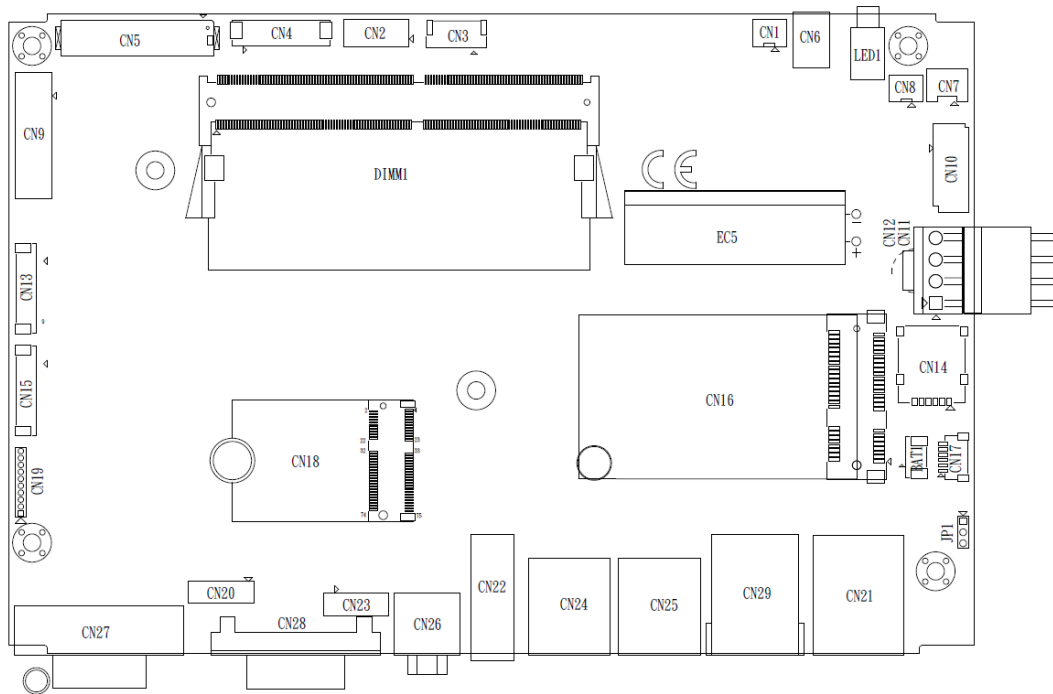

**PSB530 Bottom View**

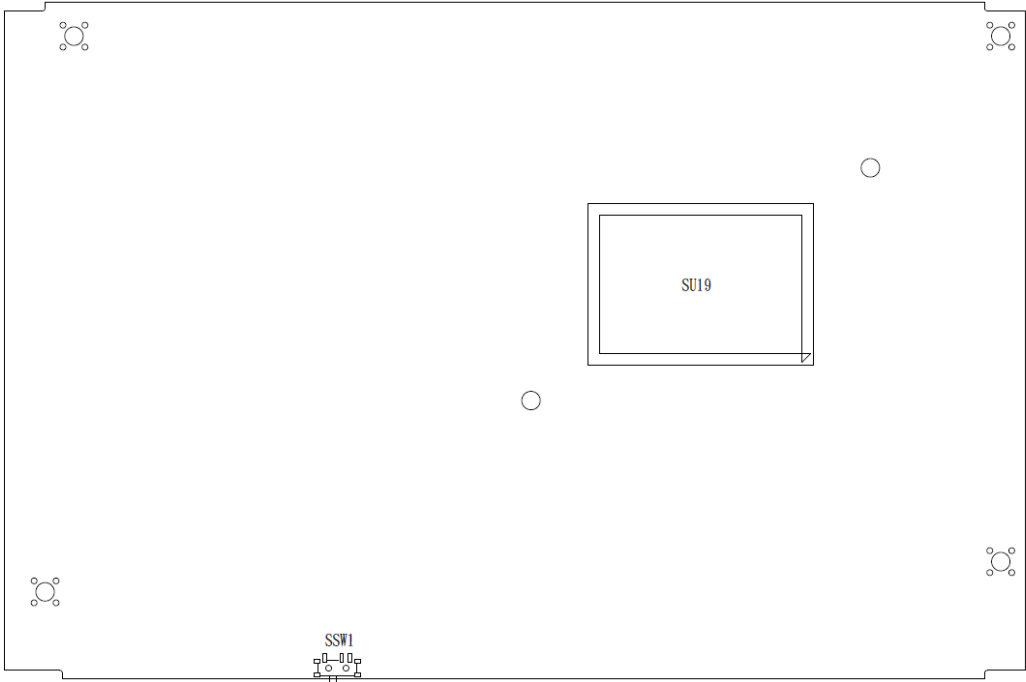



## 3.2 Summary of Jumper Settings

Proper jumper settings configure the to meet various application purposes. A table of all jumpers and their default settings is listed below.

Jumpers	Descriptions	Settings
JP1	Restore BIOS Optimal Defaults Default: Normal Operation	Short 1-2



### 【Note】 : How to setup Jumpers

That a cap on a jumper is to “close” the jumper, whereas that offs a jumper is to “open” the jumper.



[Open]



[Closed]



[Pin1-2 Closed]

### 3.2.1 Restore BIOS Optimal Defaults (JP1)

Put jumper clip to pin 2-3 for a few seconds then move it back to pin 1-2. This procedure is to restore BIOS optimal defaults.

Functions	Settings
Normal (Default)	1-2 closed
Clear RTC	2-3 closed



### 3.3 Connectors

Please refer to below connector table to get their pin assignments.

<b>External Connectors</b>	<b>Sections</b>
DC-in Phoenix Power Connector (CN1)	3.3.1
HDMI Connector (CN22)	3.3.2
VGA Connector (CN28)	3.3.3
Serial Port Connector (CN27, CN13, CN15)	3.3.4
USB 3.2 Connector (CN24, CN25)	3.3.5
Ethernet Connector (CN29, CN21)	3.3.6
ATX Power On/Off Button (SW1)	3.3.7
Remote Power Switch Connector (PWRBT1)	3.3.8
AT/ATX Quick Switch (SSW1)	3.3.9
<b>Internal Connectors</b>	<b>Sections</b>
SATA Power Connector (CN7)	3.3.10
SATA Signal Connector (CN10)	3.3.11
SIM Slot (CN14)	3.3.12
Full-Size Express Mini Card slot (CN16)	3.3.13
M.2 Key E (CN18)	3.3.14
Audio (CN26)	3.3.15

### 3.3.1 DC-in Phoenix Power Connector (CN1)

The system supports 9~36V Phoenix DC-in connector for system power input.

Pins	Signals
1	DC+
2	GND
3	DC-

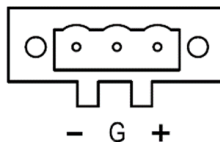

### 3.3.2 HDMI Connector (CN22)

The HDMI (High-Definition Multimedia Interface) is a compact digital interface which is capable of transmitting high-definition video and high-resolution audio over a single cable.

Pin	Signals	Pin	Signals
1	HDMI OUT_DATA2+	11	GND
2	GND	12	HDMI OUT Clock-
3	HDMI OUT_DATA2-	13	N.C.
4	HDMI OUT_DATA1+	14	N.C.
5	GND	15	HDMI OUT_SCL
6	HDMI OUT_DATA1-	16	HDMI OUT_SDA
7	HDMI OUT_DATA0+	17	GND
8	GND	18	+5V
9	HDMI OUT_DATA0-	19	HDMI_HTPLG
10	HDMI OUT Clock+		

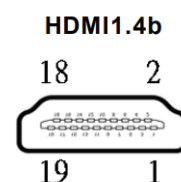

### 3.3.3 VGA Connector (CN28)

supports one VGA (DB15) output.

Pins	Signals	Pins	Signals
1	RED	2	GREEN
3	BLUE	4	N.C
5	GND	6	GND
7	CRT_VCC	8	GND
9	CRT_VCC	10	GND
11	N.C	12	DDC_DATA
13	Hsync	14	Vsync
15	DDC_CLK		

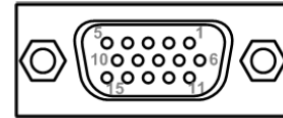

### 3.3.4 Serial Port Connector (CN27, CN13, CN15)

The system has three serial ports. COM1 is RS-232/422/485 ports. COM2~COM3 are RS-232. Please refer to Chapter 4 for the detail of BIOS setting.

CN27: RS-232/422/485 (COM1)

CN13, CN15: RS-232 (COM2, COM3)

Pin	RS-232	RS-422	RS-485
1	DCD	TX-	Data-
2	RXD	TX+	Data+
3	TXD	RX+	N/C
4	DTR	RX-	N/C
5	GND	GND	GND
6	DSR	N/C	N/C
7	RTS	N/C	N/C
8	CTS	N/C	N/C
9	RI	N/C	N/C

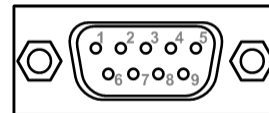

### 3.3.5 USB 3.2 Connector (CN24, CN25)

The system has six USB port, four port compliant with USB 3.2 gen1 (5GB/s), two port compliant with USB 2.0 (480MB/s), and ideally for installing USB peripherals such as scanner, camera, and USB devices, etc.

USB 3.0 (CN24, CN25)

Pins	Signal USB Port 0	Pins	Signal USB Port 1
1	USB_VCC (+5V level standby power)	10	USB_VCC (+5V level standby power)
2	USB_Data-	11	USB_Data-
3	USB_Data+	12	USB_Data+
4	GND	13	GND
5	SSRX-	14	SSRX-
6	SSRX+	15	SSRX+
7	GND	16	GND
8	SSTX-	17	SSTX-
9	SSTX+	18	SSTX+

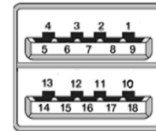
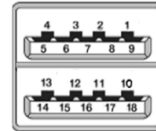

USB 2.0 (CN2, wafer, dual port)

Pins	Signal USB Port 0	Pins	Signal USB Port 1
1	USB_VCC (+5V level standby power)	3	USB_Data+
2	USB_Data-	4	GND

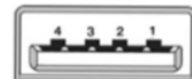

### 3.3.6 Ethernet Connector (CN29, CN21)

The  has two RJ-45 connectors: LAN1 (CN29) and LAN2 (CN21).

LAN1 is designed by Intel i226-LM and LAN2 is Intel i210-AT.

#### Pin assignment for LAN1 (i226-LM, CN29)

Pins	2500/1000 Base-T	100/10 Base-T	Description
L1	BI_DA+	TX+	Bidirectional or Transmit Data+
L2	BI_DA-	TX-	Bidirectional or Transmit Data-
L3	BI_DB+	RX+	Bidirectional or Receive Data+
L4	BI_DC+	N.C.	Bidirectional or Not Connected
L5	BI_DC-	N.C.	Bidirectional or Not Connected
L6	BI_DB-	RX-	Bidirectional or Receive Data-
L7	BI_DD+	N.C.	Bidirectional or Not Connected
L8	BI_DD-	N.C.	Bidirectional or Not Connected
A	Active Link LED (Yellow) Off: No link Blinking: Data activity detected		
B	Speed LED 2500: Green 1000: Orange 100/10: OFF		

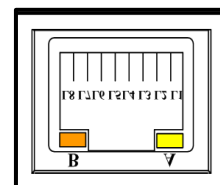

**2.5G  
LAN 1**

#### Pin assignment for LAN2 (i210-AT, CN21)

Pins	1000 Base-T	100/10 Base-T	Description
L1	BI_DA+	TX+	Bidirectional or Transmit Data+
L2	BI_DA-	TX-	Bidirectional or Transmit Data-
L3	BI_DB+	RX+	Bidirectional or Receive Data+
L4	BI_DC+	N.C.	Bidirectional or Not Connected
L5	BI_DC-	N.C.	Bidirectional or Not Connected
L6	BI_DB-	RX-	Bidirectional or Receive Data-
L7	BI_DD+	N.C.	Bidirectional or Not Connected
L8	BI_DD-	N.C.	Bidirectional or Not Connected
A	Active Link LED (Yellow) Off: No link Blinking: Data activity detected		
B	Speed LED 1000: Orange 100/10: Green/OFF		

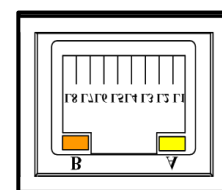

**1G  
LAN 2**

### 3.3.7 ATX Power On/Off (SW1)

The ATX power button is on the I/O side. It can allow users to control power on/off.

Functions	Descriptions
On	Turn on/off system
Off	Keep system status

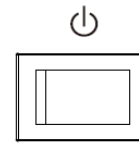

### 3.3.8 Remote Power Switch Connector (PWRBT1)

One 2-pin connector output for remote power on/off switch.

Functions	Descriptions
Short (1-2)	Turn on/off system
Open	Keep system status

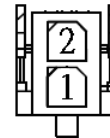

### 3.3.9 ATX/AT Quick Switch (SSW1)

If you set ATX /AT switch to AT mode, the system will be automatically power on without pressing soft power button during power input; we can use this switch to achieve auto power on demand.

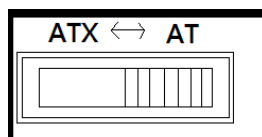

### 3.3.10 SATA Power Connector (CN7)

Based on CN7 to offer the SATA power for SATA 2.5" HDD/SSD.

Pins	Signals
1	+5V level
2	GND

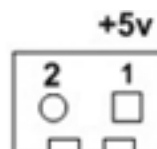

### 3.3.11 SATA Connector (CN10)

The Serial Advanced Technology Attachment (Serial ATA or SATA) connector is for high-speed SATA interfaces. It is computer bus interfaces for connecting to devices such as hard disk drives. This board has one SATA 3.0 ports with 6Gb/s performance.

Pins	Signals
1	GND
2	SATA_TX+
3	SATA_TX-
4	GND
5	SATA_RX-
6	SATA_RX+
7	GND

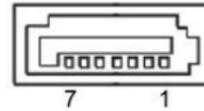

### 3.3.12 Nano SIM Card Slot (CN14)

The board has one SIM slots: CN14 on top side that support mini PCIe slot (for CN18). It is mainly used in wireless network application.

Pin	Signal
C1	PWR
C2	RST
C3	CLK
C4	NC
C5	GND
C6	VPP
C7	I/O





### 3.3.13 Full-Size PCI Express Mini Card Slot (CN16)

The                      supports one full-size PCI-Express Mini Card slot.

CN16 is applying for PCI-Express or SATA (mSATA) via BIOS selection and USB signals; PCI-Express complies with PCI-Express Mini Card Spec. V1.2. Thus, users can install mSATA or WLAN/WWAN cards into this slot. Please refer to the SATA of BIOS setting to enable or disable mSATA supported. CN14 support SIM slot.

Pins	Signals	Pins	Signals
1	WAKE#	2	+3.3VSB
3	No use	4	GND
5	No use	6	+1.5V
7	CLKREQ# 8 No use	8	No use
9	GND	10	No use
11	REFCLK-	12	No use
13	REFCLK+	14	No use
15	GND	16	No use
17	No use	18	GND
19	No use	20	W_DISABLE#
21	GND	22	PERST#
23	PE_RXN3/	24	+3.3VSB
25	PE_RXP3/	26	GND
27	GND	28	+1.5V
29	GND	30	SMB_CLK
31	PE_TXN3/	32	SMB_DATA
33	SATA_TXN	34	GND
35	GND	36	USB_D8-
37	GND	38	USB_D8+
39	+3.3VSB	40	GND
41	+3.3VSB	42	No use
43	GND	44	No use
45	No use	46	No use
47	No use	48	+1.5V
49	No use	50	GND
51	No use	52	+3.3VSB

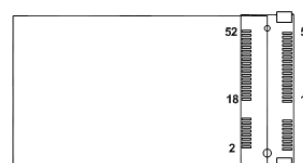

### 3.3.14 M.2 2230 Key E slot (CN18)

The M.2 2230 Key E for WIFI Module.

Pins	Signals	Pins	Signals	Pins	Signals	Pins	Signals
1	GND	2	+3.3V	3	USB_D+	4	+3.3V
5	USB_D-	6	NC	7	GND	8	NC
9	NC	10	NC	11	NC	12	NC
13	NC	14	NC	15	NC	16	NC
17	NC	18	GND	19	NC	20	NC
21	NC	22	NC	23	NC	24	CONNECTOR KEY E
25	CONNECTOR KEY E	26	CONNECTOR KEY E	27	CONNECTOR KEY E	28	CONNECTOR KEY E
29	CONNECTOR KEY E	30	CONNECTOR KEY E	31	CONNECTOR KEY E	32	NC
33	GND	34	NC	35	PETp0	36	NC
37	PETn0	38	NC	39	GND	40	NC
41	PERp0	42	NC	43	PERn0	44	NC
45	GND	46	NC	47	REFCLKp0	48	NC
49	REFCLKn0	50	SUSCLK	51	GND	52	PERST0#
53	CLKREQ0#	54	W_DISABLE2#	55	PEWAKE0#	56	W_DISABLE1#
57	GND	58	NC	59	NC	60	NC
61	NC	62	NC	63	GND	64	NC
65	NC	66	NC	67	NC	68	NC
69	GND	70	NC	71	NC	72	+3.3V
73	NC	74	+3.3V	75	GND		

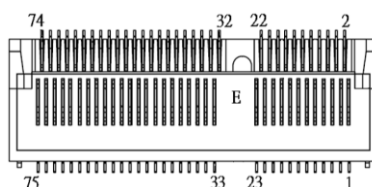

### 3.3.15 Intel® HD Audio Digital Header (CN26)

The audio jack is ideal for Audio Line-out.

Pin	Signal
1	Line Out



Line out

**This page is intentionally left blank.**

## SECTION 4 BIOS SETUP UTILITY

This section provides users with detailed descriptions in terms of how to set up basic system configurations through the BIOS setup utility.

### 4.1 Starting

To enter the setup screens, follow the steps below:

1. Turn on the computer and press the <Del> key immediately.
2. After pressing the <Del> key, the main BIOS setup menu displays. Users can access other setup screens, such as the Advanced and Chipset menus, from the main BIOS setup menu.

It is strongly recommended that users should avoid changing the chipset's defaults. Both AMI and system manufacturer have carefully set up these defaults that provide the best performance and reliability.

### 4.2 Navigation Keys

The BIOS setup/utility uses a key-based navigation system called hot keys. Most of the BIOS setup utility hot keys can be used at any time during the setup navigation process. These keys include <F1>, <F2>, <Enter>, <ESC>, <Arrow> keys, and so on.



**【Note】** : *Some of the navigation keys differ from one screen to another.*

Hot Keys	Descriptions
←→ Left/Right	The Left and Right <Arrow> keys allow users to select a setup screen.
↑↓ Up/Down	The Up and Down <Arrow> keys allow users to select a setup screen or sub-screen.
+– Plus/Minus	The Plus and Minus <Arrow> keys allow users to change the field value of a particular setup item.
Tab	The <Tab> key allows users to select setup fields.
F1	The <F1> key allows users to display the General Help screen.
F2	The <F2> key allows users to Load Previous Values.
F3	The <F3> key allows users to Load Optimized Defaults.
F4	The <F4> key allows users to save any changes they made and exit the Setup. Press the <F4> key to save any changes.
Esc	The <Esc> key allows users to discard any changes they made and exit the Setup. Press the <Esc> key to exit the setup without saving any changes.
Enter	The <Enter> key allows users to display or change the setup option listed for a particular setup item. The <Enter> key can also allow users to display the setup sub- screens.

## 4.3 Main Menu

The Main Menu screen is the first screen users see when entering the setup utility. Users can always return to the Main setup screen by selecting the Main tab. System Time/Date can be set up as described below. The Main BIOS setup screen is also shown below.



### BIOS Information

Display the auto-detected BIOS information.

### System Date/Time

Use this option to change the system time and date. Highlight System Time or System Date using the <Arrow> keys. Enter new values through the keyboard. Press the <Tab> key or the <Arrow> keys to move between fields. The date must be entered in MM/DD/YY format. The time is entered in HH:MM:SS format.

### Access Level

Display the access level of current user.

## 4.4 Advanced Menu

The Advanced menu also allows users to set configuration of the CPU and other system devices. Users can select any items in the left frame of the screen to go to sub menus:

- ▶ Trusted Computing
- ▶ CPU Configurations
- ▶ Storage Configuration
- ▶ USB Configuration
- ▶ F81966 Super IO Configuration
- ▶ Hardware monitor
- ▶ DIO Configuration (optional)

For items marked with “▶”, please press <Enter> for more options.



## Trust Computing

If users install a security device, such as TPM, users will see the following information for the TPM device and status.

The screenshot displays the 'Advanced' menu in the Aptio Setup - AMI BIOS. The menu is divided into two columns. The left column lists TPM-related information, and the right column provides a detailed description of the TPM 2.0 Device Found status and navigation instructions.

Advanced		Aptio Setup - AMI
TPM 2.0 Device Found		Enables or Disables BIOS support for security device. O.S. will not show Security Device. TCG EFI protocol and INT1A interface will not be available.
Firmware Version:	1.258	
Vendor:	STM	
Security Device Support	[Enable]	
Active PCR banks	SHA256	
Available PCR banks	SHA256	
Pending operation	[None]	
		⇧⇧: Select Screen ⇧↓: Select Item Enter: Select +/-: Change Opt. F1: General Help F2: Previous Values F3: Optimized Defaults F4: Save & Exit ESC: Exit
Version 2.22.1282 Copyright (C) 2022 AMI		



## CPU Configuration

This screen shows the CPU version and its detailed information.

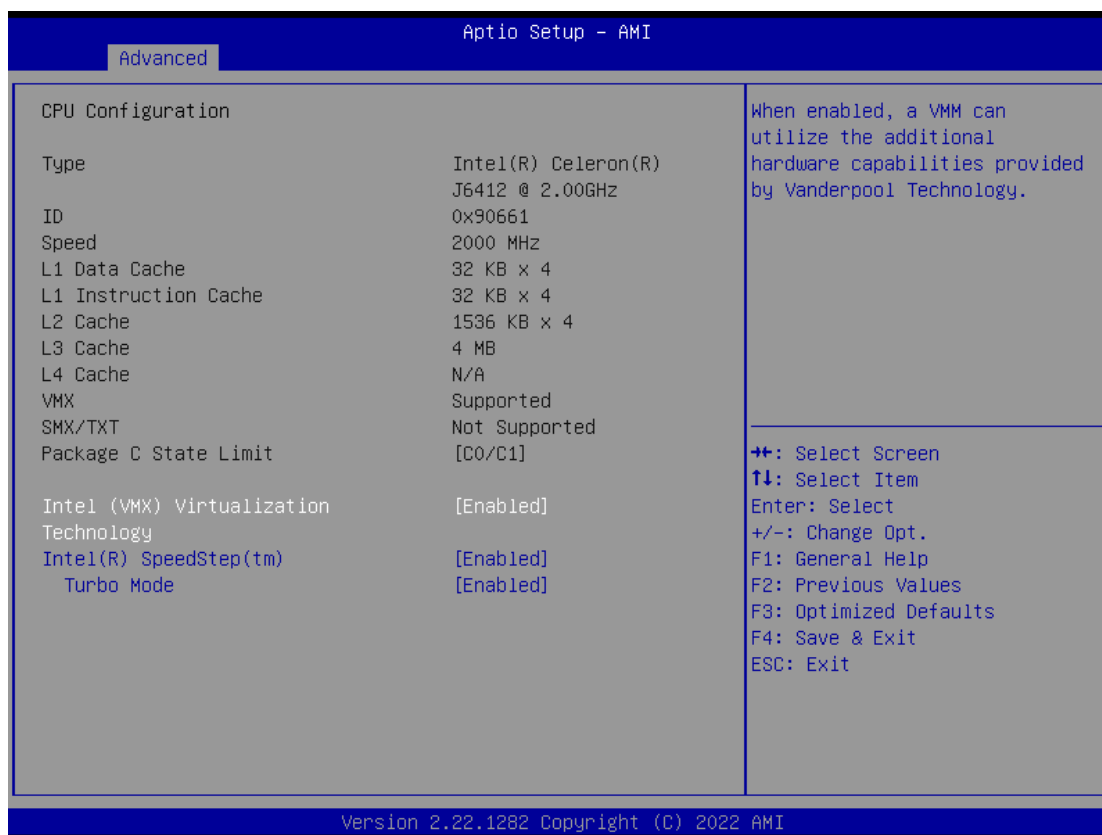

### Intel Virtualization Technology

Enable or disable Intel Virtualization Technology. When enabled, a VMM (Virtual Machine Mode) can utilize the additional hardware capabilities. It allows a platform to run multiple operating systems and applications independently, hence enabling a single computer system to work as several virtual systems.

### Intel (R) SpeedStep(tm)

Allows more than two frequency ranges to be supported.

### Turbo Mode

Enable/Disable processor Turbo Mode (requires EMTTM enabled too).

## Storage Configuration

This screen allows users to select options for SATA Configuration, and change the value of the selected option.

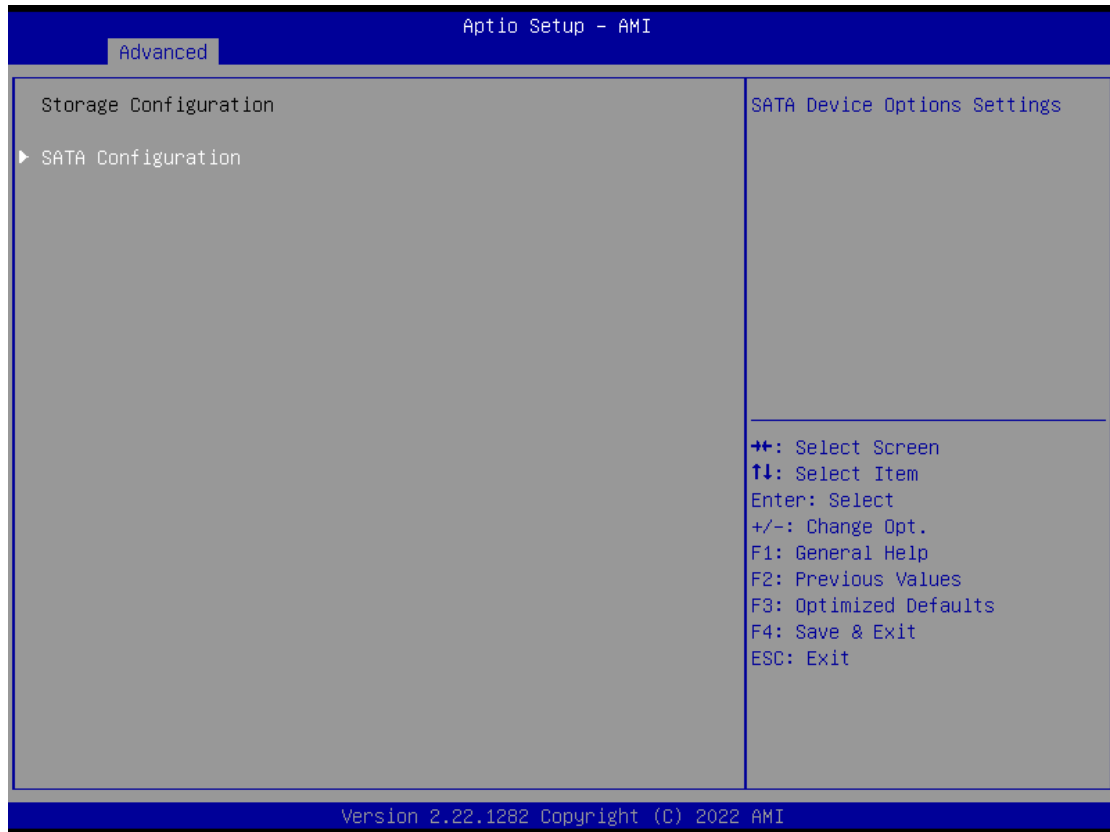

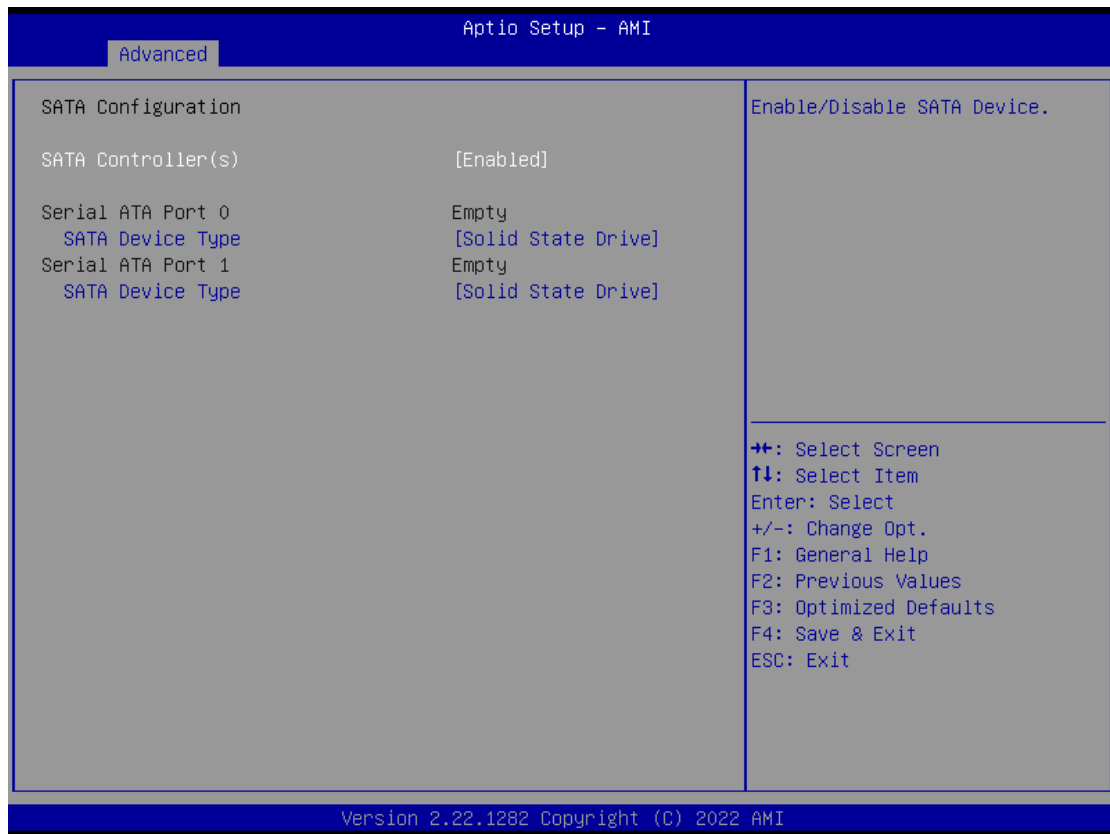

### SATA Controller

Highlight this item to enable or disable SATA Controller.

## USB Configurations

Display all detected USB devices.

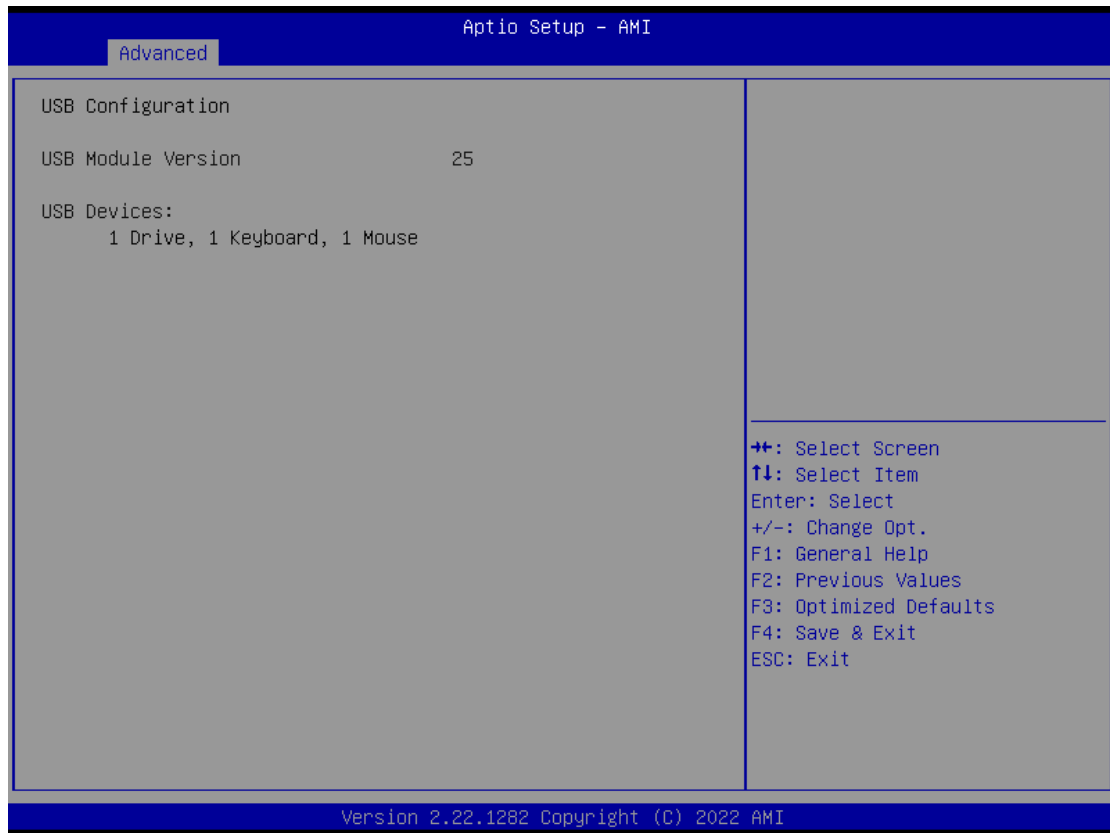

## F81966 Super IO Configurations

Use this screen to select options for the F81966 Super IO Configurations and change the value of the selected option. A description of the selected item appears on the right side of the screen. For items marked with “▶”, please press <Enter> for more options



## Serial Port 1~3 (COM1~3) Configurations

Use these items to set parameters related to serial ports COM1 (RS232/422/485)  
Use these items to set parameters related to serial ports COM2~3 (RS232 only)

## Serial Port 1

Use this to set parameters of COM 1 (RS232/422/485).

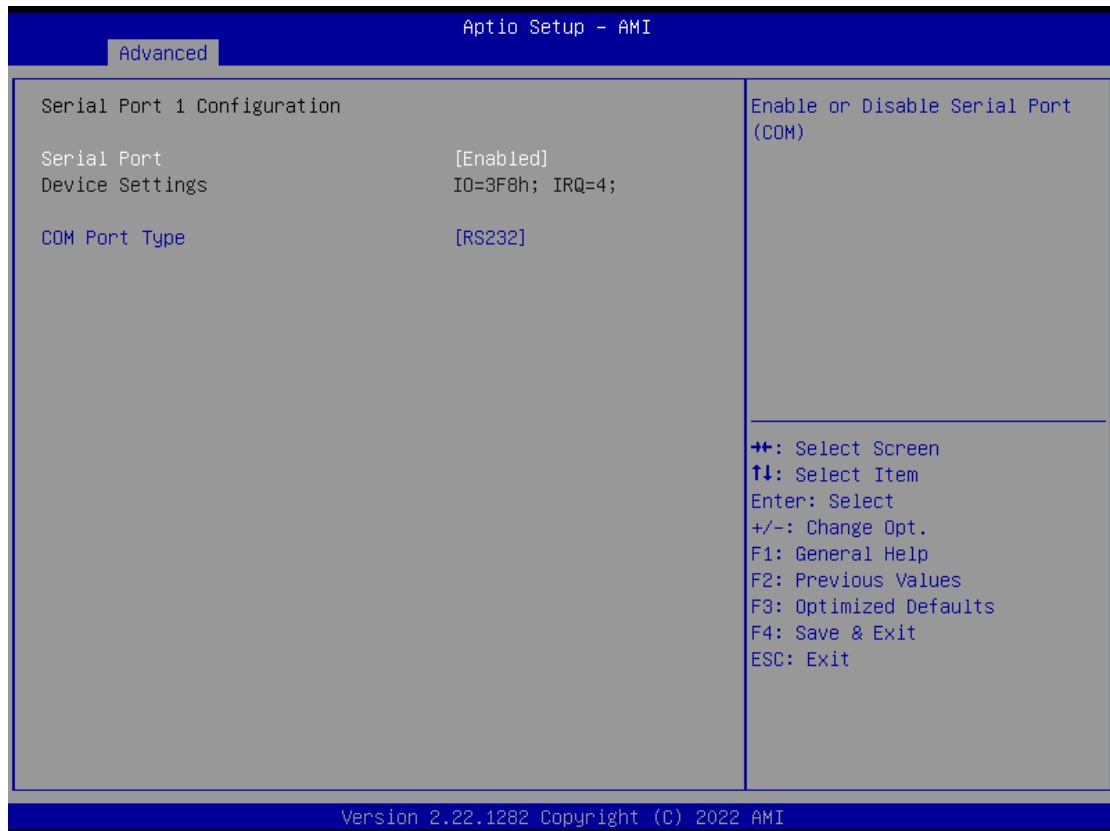

## Serial Port

Enable or disable serial port 1. The optimal setting for base I/O address is 3F8h and for interrupt request address is IRQ4.

## COM Port Type

Use this item to set RS-232/422/485 communication mode.

## Serial Port 2

Use this to set parameters of COM 2 (RS-232).

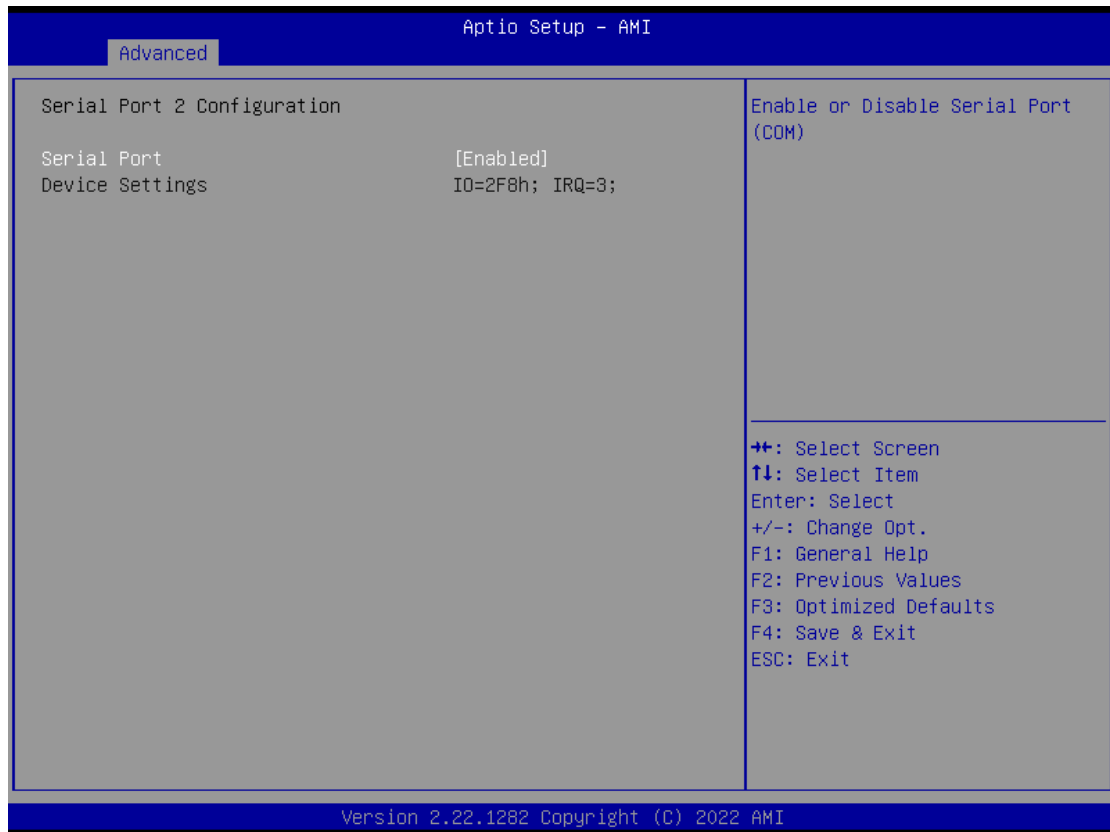

## Serial port

Enable or disable serial port 2. The optimal setting for base I/O address is 2F8h and for interrupt request address is IRQ3.

### Serial Port 3

Use this to set parameters of COM 3 (RS232).



### Serial port

Enable or disable serial port 3. The optimal setting for base I/O address is 3E8h and for interrupt request address is IRQ7.



## Hardware Monitor

This screen monitors hardware health status.

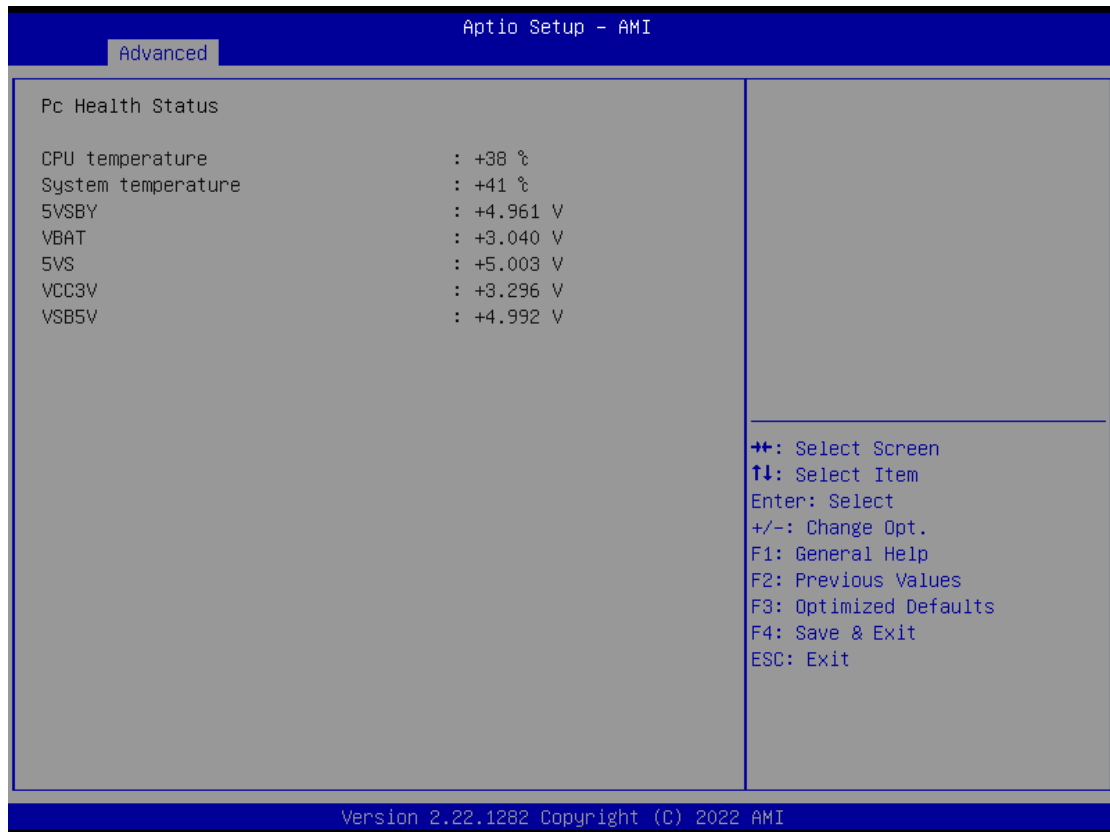

This screen displays the temperature of system and CPU as well as system voltages (VBAT, 5VSBY, 5VS, VCC3V and VSB5V).

## DIO Configuration

Users can adjust the option 8-CH DIO default setting via this page. doesn't  
support 8-CH DIO for standard version, users can order the DIO cable kit then change the  
option port (COM 3) to support 8-CH TTL DIO.

The screenshot displays the 'Advanced' menu of the Aptio Setup - AMI BIOS. The main area is divided into two columns. The left column lists DIO configurations for DI00 through DI07. Each configuration shows 'Input/Output' and 'High/Low' settings, both currently set to '[Output]' and '[High]' respectively. The right column is titled 'DIO Input/Output setting' and contains a list of navigation and function keys: ←→: Select Screen, ↑↓: Select Item, Enter: Select, +/-: Change Opt., F1: General Help, F2: Previous Values, F3: Optimized Defaults, F4: Save & Exit, and ESC: Exit. At the bottom of the screen, the version '2.22.1282' and copyright '© 2022 AMI' are displayed.

Configuration	Input/Output	High/Low
DI00 Configuration	[Output]	[High]
DI01 Configuration	[Output]	[High]
DI02 Configuration	[Output]	[High]
DI03 Configuration	[Output]	[High]
DI04 Configuration	[Output]	[High]
DI05 Configuration	[Output]	[High]
DI06 Configuration	[Output]	[High]
DI07 Configuration	[Output]	[High]

Navigation and Function Keys:

- ←→: Select Screen
- ↑↓: Select Item
- Enter: Select
- +/-: Change Opt.
- F1: General Help
- F2: Previous Values
- F3: Optimized Defaults
- F4: Save & Exit
- ESC: Exit

Version 2.22.1282 Copyright (C) 2022 AMI

## 4.5 Chipset Menu

The Chipset menu allows users to change the advanced chipset settings. Users can select any of the items in the left frame of the screen to go to the sub menus:

- ▶ System Agent (SA) Configurations
- ▶ PCH-IO Configurations

For items marked with “▶”, please press <Enter> for more options.

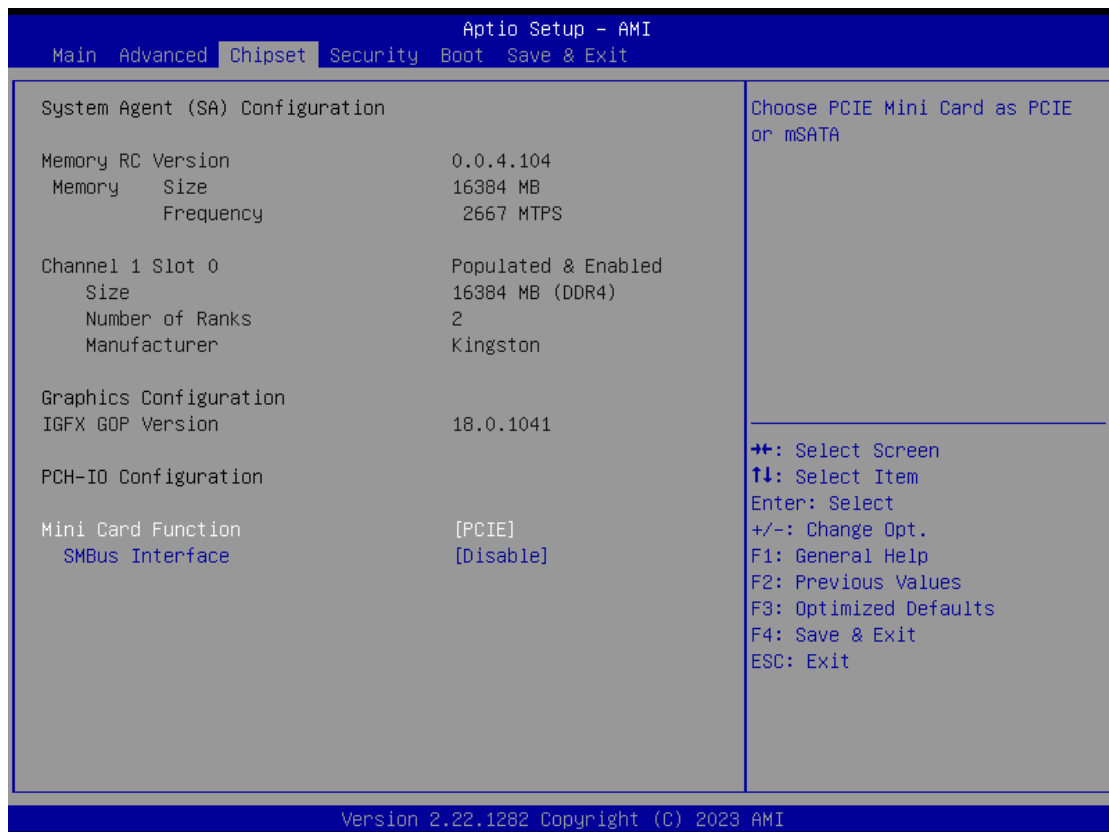

## Mini Card Function

Choose PCIE Mini Card as PCIE or mSATA

The screenshot displays the BIOS configuration utility with the following details:

- Title Bar:** Aptio Setup - AMI
- Navigation Menu:** Main | Advanced | **Chipset** | Security | Boot | Save & Exit
- Main Content Area:**
  - System Agent (SA) Configuration:** Memory RC Version (0.0.4.104), Memory Size (16384 MB), Memory Frequency (2667 MTSPS).
  - Channel 1 Slot 0:** Populated & Enabled, Size (16384 MB (DDR4)), Number of Ranks (2), Manufacturer (Kingston).
  - Graphics Configuration:** IGFX GOP Version.
  - PCH-I/O Configuration:** Mini Card Function ([mSATA]), SMBus Interface ([Disable]).
- Mini Card Function Sub-menu:** A blue box highlights the options: Mini Card Function, PCIE, and mSATA.
- Right Panel:** Choose PCIE Mini Card as PCIE or mSATA. Below this is a legend: **⇐**: Select Screen, **↑↓**: Select Item, **Enter**: Select, **+/-**: Change Opt., **F1**: General Help, **F2**: Previous Values, **F3**: Optimized Defaults, **F4**: Save & Exit, **ESC**: Exit.
- Footer:** Version 2.22.1282 Copyright (C) 2023 AMI

## SMBus Interface

Choose PCIE Mini Card support SMBus Interface only for AX module

The screenshot displays the Aptio Setup - AMI BIOS interface. The 'Chipset' tab is selected, and the 'SMBus Interface' option is highlighted. A sub-menu is open, showing 'Disable' and 'Enable' options. The 'Mini Card Function' is set to '[mSATA]' and the 'SMBus Interface' is currently set to '[Disable]'. The right side of the screen shows the 'Choose PCIE Mini Card Support SMBus Interface' option and a list of navigation keys.

Section	Item	Value
System Agent (SA) Configuration	Memory RC Version	0.0.4.104
Memory	Size	16384 MB
	Frequency	2667 MTPS
Channel 1 Slot 0	Size	16384 MB (DDR4)
	Number of Ranks	2
	Manufacturer	Kingston
Graphics Configuration	IGFX GOP Version	[mSATA]
PCH-IO Configuration	Mini Card Function	[mSATA]
	SMBus Interface	[Disable]

Choose PCIE Mini Card Support SMBus Interface

Disable  
Enable

++: Select Screen  
↑↓: Select Item  
Enter: Select  
+/-: Change Opt.  
F1: General Help  
F2: Previous Values  
F3: Optimize Defaults  
F4: Save & Exit  
ESC: Exit

Version 2.22.1282 Copyright (C) 2023 AMI

## Security Menu

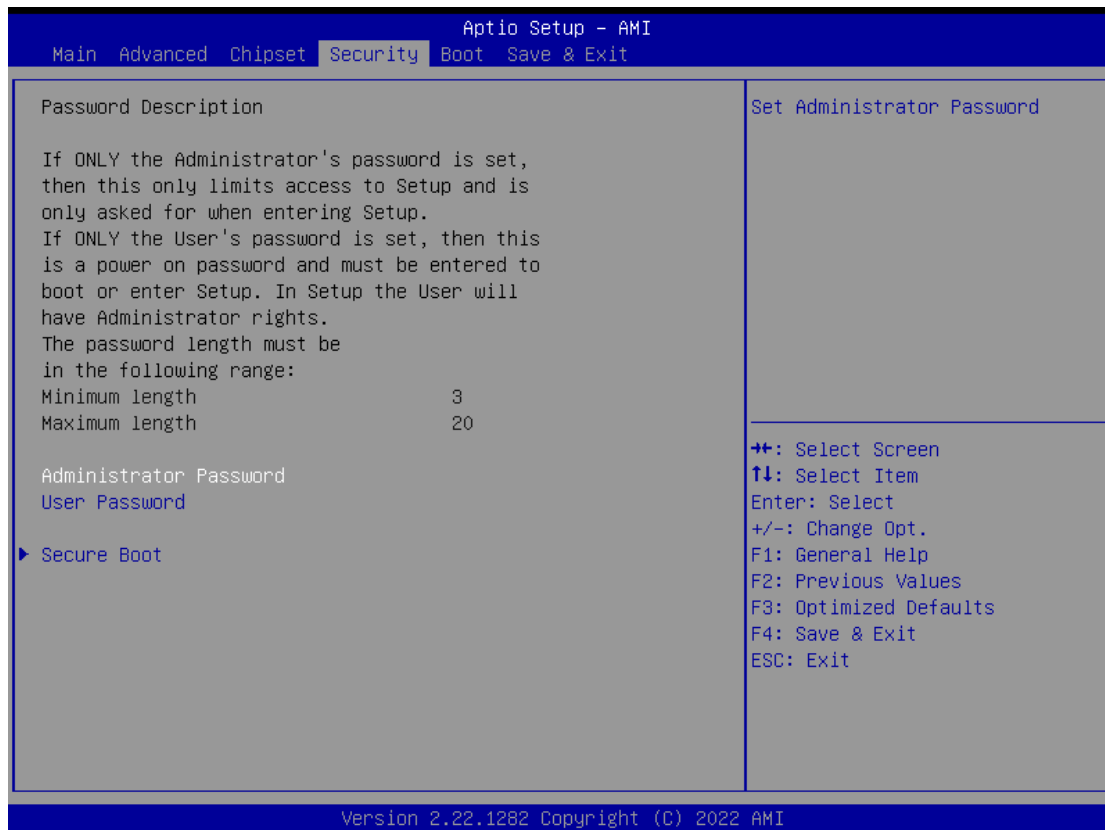

### Administrator Password

This item indicates whether an administrator password has been set (installed or uninstalled).

### User Password

This item indicates whether a user password has been set (installed or uninstalled).

### Secure Boot

Secure Boot feature is Active if Secure Boot is Enabled or Disable.

## Secure Boot

Use this item to enable or disable support for Secure Boot.



### Secure Boot Mode

Secure Boot mode options: Standard or Custom.

In Custom mode, Secure Boot Policy variables can be configured by a physically present user without full authentication

### Restore Factory Keys

Force System to User Mode. Install factory default Secure Boot key databases.

### Reset to Setup Mode

Delete all Secure Boot key databases from NVRAM.

### Key Management

Secure Boot feature is Active if Secure Boot is Enabled or Disable .

## Key management

Install factory default Secure Boot key the platform rest and while the System is in Setup mode.

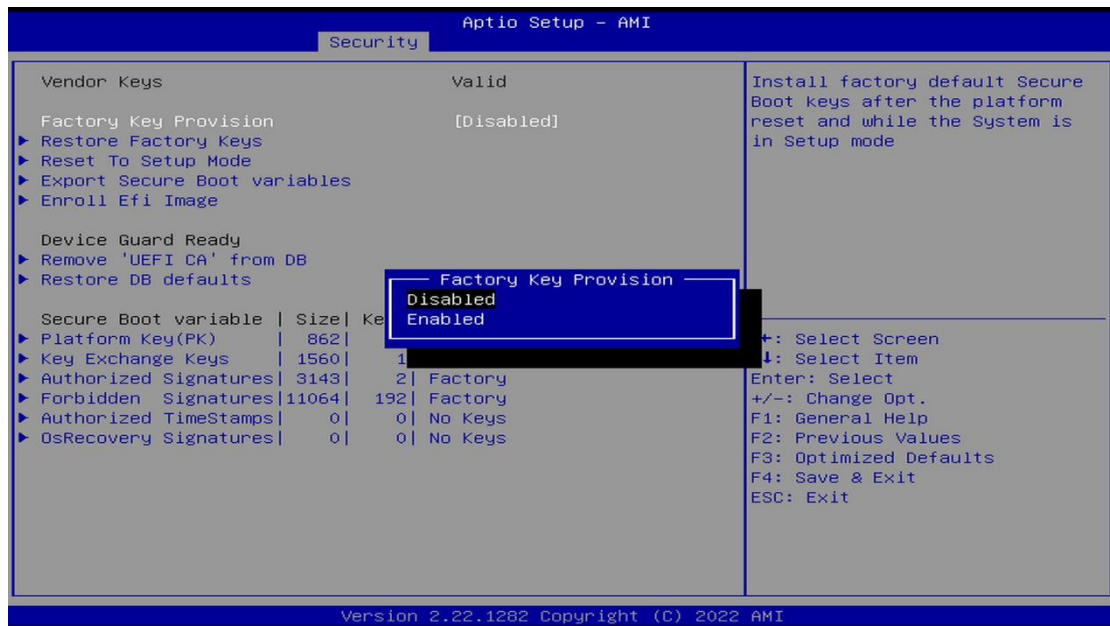
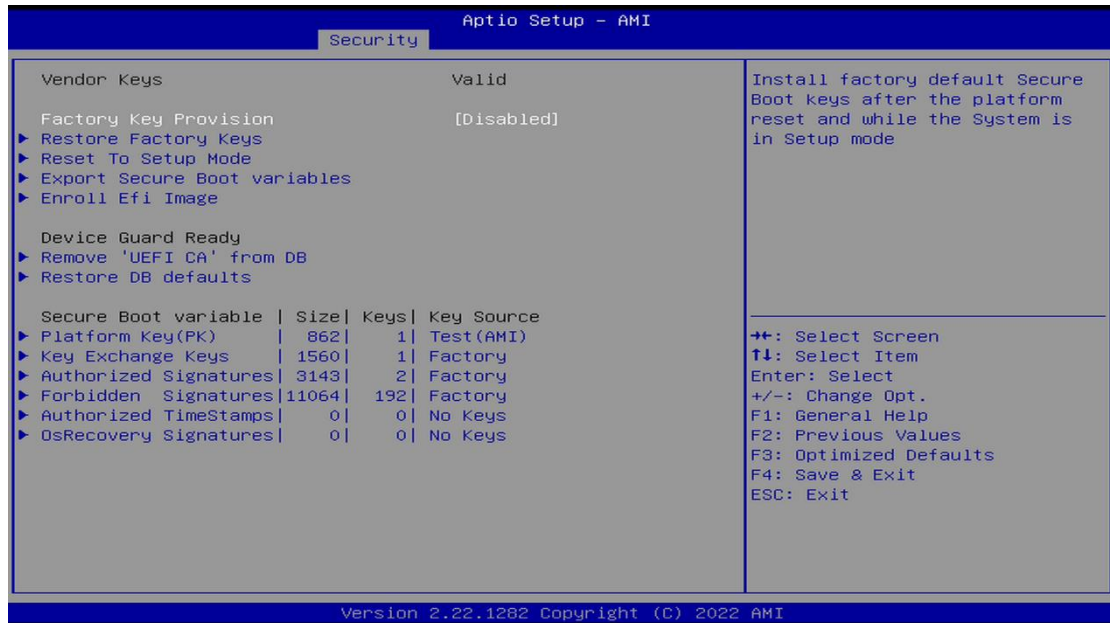



## 4.6 Boot Menu

The Boot menu allows users to change boot options of the system.

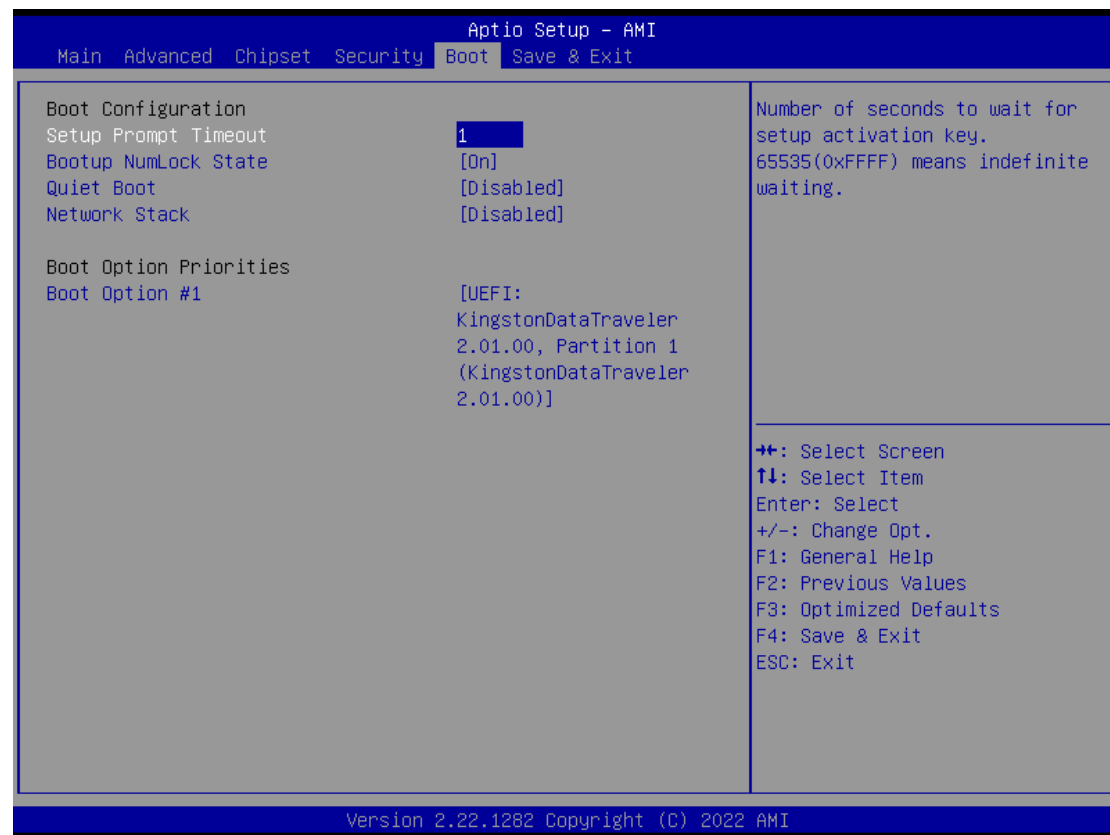

### Setup Prompt Timeout

Use this item to set up number of seconds to wait for setup activation key where 65535(0xFFFF) means indefinite waiting.

### Bootup NumLock State

Use this item to select the power-on state for the keyboard NumLock.

### Quiet Boot

Select to display either POST output messages or a splash screen during boot-up.

### Network Stack

Enable/Disable UEFI Network Stack. Default setting is Enabled

### Launch PXE OpROM policy

Enables UEFI to run those devices that support UEFI option ROM only. Selecting Legacy enables only devices that support legacy option ROM only.

### Boot Option Priorities

These are settings for boot priority. Specify the boot device priority sequence from the available devices.

## 4.7 Save & Exit Menu

The Save & Exit menu allows users to load system configurations with optimal or fail-safe default values.

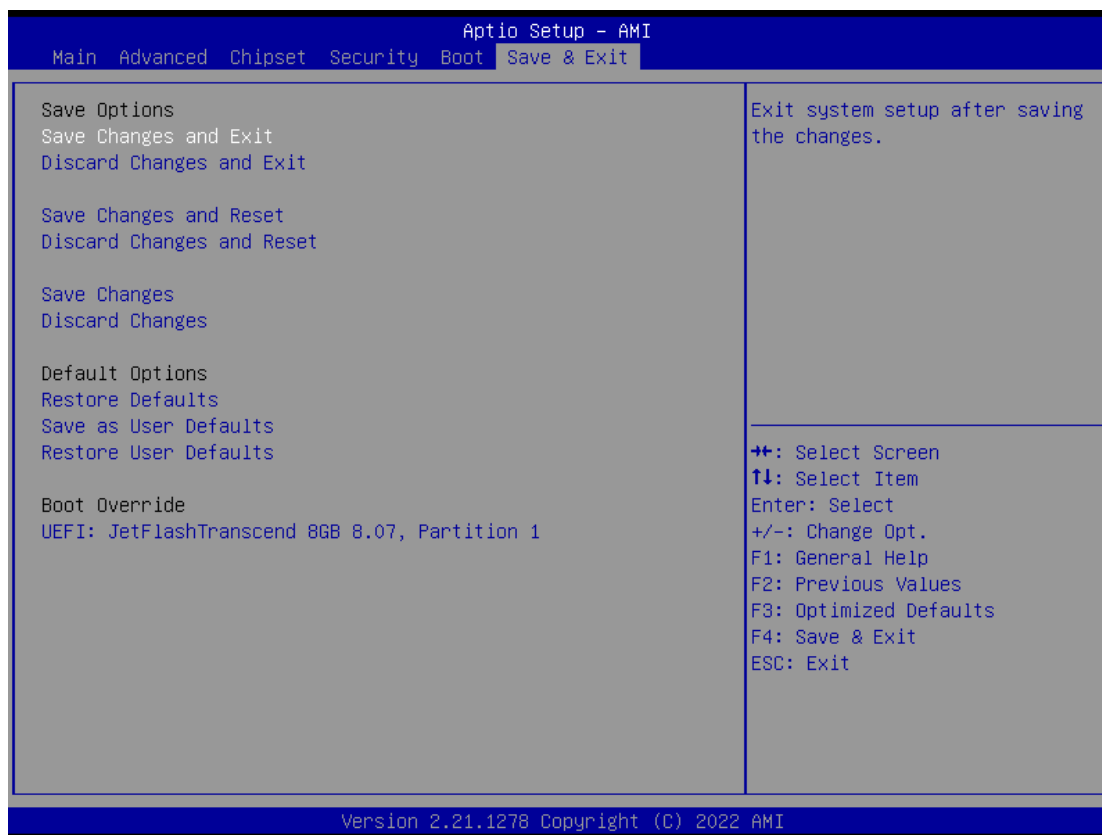

### Save Changes and Exit

When users have completed the system configuration changes, select this option to leave Setup and return to Main Menu. Select Save Changes and Exit from the Save & Exit menu and press <Enter>. Select Yes to save changes and exit.

### Discard Changes and Exit

Select this option to quit Setup without making any permanent changes to the system configurations and return to Main Menu. Select Discard Changes and Exit from the Save & Exit menu and press <Enter>. Select Yes to discard changes and exit.

### Save Changes and Reset

Having completed the system configuration changes, select this option to leave Setup and reboot the computer so the new system configurations take effect. Select Save Changes and Reset from the Save & Exit menu and press <Enter>. Select Yes to save changes and reset.

### Discard Changes and Reset

Select this option to quit Setup without making any permanent changes to the system configuration and reboot the computer. Select Discard Changes and Reset from the Save & Exit menu and press <Enter>. Select Yes to discard changes and reset.

**Save Changes**

Having completed the system configuration changes, select this option to save changes. Select Save Changes from the Save & Exit menu and press <Enter>. Select Yes to save changes.

**Discard Changes**

Select this option to quit Setup without making any permanent changes to the system configurations. Select Discard Changes from the Save & Exit menu and press <Enter>. Select Yes to discard changes.

**Restore Defaults**

It automatically sets all Setup options to a complete set of default settings when users select this option. Select Restore Defaults from the Save & Exit menu and press <Enter>.

**Save as User Defaults**

Select this option to save system configuration changes done so far as User Defaults. Select Save as User Defaults from the Save & Exit menu and press <Enter>.

**Restore User Defaults**

It automatically sets all Setup options to a complete set of User Defaults when users select this option. Select Restore User Defaults from the Save & Exit menu and press <Enter>.

**Boot Override**

Select a drive to immediately boot that device regardless of the current boot order.

**This page is intentionally left blank.**