

8B32

Current Input Modules

Description

8B modules are an optimal solution for monitoring real-world process signals and providing high-level signals to a data acquisition system. Each 8B32 module isolates, filters, and amplifies a process current input signal and provides an analog voltage output.

Current to voltage conversion is accomplished internal to the module to ensure high accuracy.

Signal filtering is accomplished with a 3-pole filter optimized for time and frequency response which provides 70dB of normal-mode rejection at 60Hz. One pole of this filter is on the field side of the isolation barrier for anti-aliasing, and the other two are on the system side.

A special input circuit on the 8B32 module provides protection against accidental connection of power-line voltages up to 40VAC. Clamp circuits on the I/O and power terminals protect against harmful transients.

Isolation is provided by optical coupling to suppress transmission of common mode spikes or surges. The module is powered from +5VDC, ±5%.

The modules are designed for installation in Class I, Division 2 hazardous locations and have a high level of immunity to environmental noise.

► Features

- Accepts Milliamp Level Signals
- High-Level Voltage Outputs
- 1500Vrms Isolation
- ANSI/IEEE C37.90.1 Transient Protection
- Input Protection to 40VAC Continuous
- 120dB CMR
- 70dB NMR at 60Hz
- ±0.05% Accuracy
- ±0.02% Linearity
- Low Drift with Ambient Temperature
- CE Compliant
- C-UL-US Listed
- ATEX Compliance Pending
- Mix and Match Module Types on Backpanel

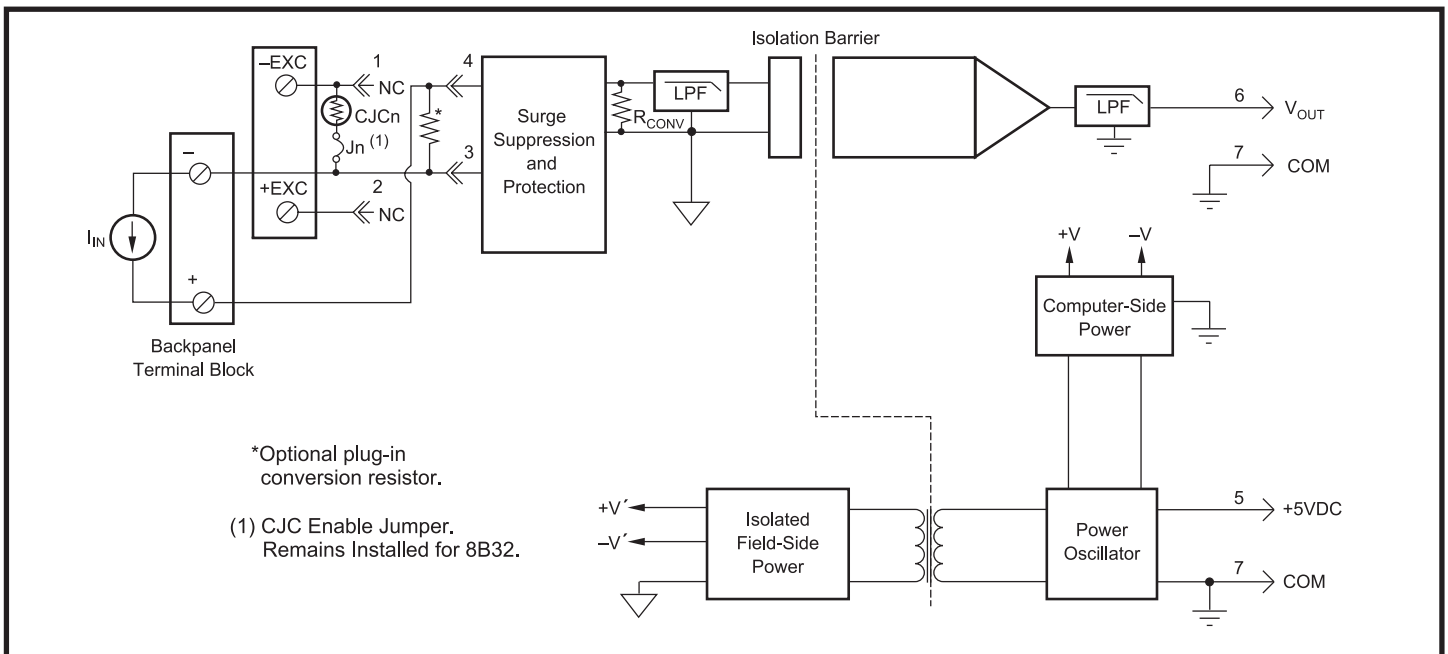

Figure 1: 8B32 Block Diagram

Specifications Typical at $T_A = +25^\circ\text{C}$ and +5V power

Module	8B32
Input Range	0mA to 20mA or 4mA to 20mA
Input Resistance	
Normal	<50 Ω
Power Off	<50 Ω
Input Protection	
Continuous	40VAC
Transient	ANSI/IEEE C37.90.1
CMV, Input to Output	1500Vrms max
Transient, Input to Output	ANSI/IEEE C37.90.1
CMR (50Hz or 60Hz)	120dB
NMR	70dB at 60Hz
Accuracy ⁽¹⁾	$\pm 0.05\%$ Span
Linearity	$\pm 0.02\%$ Span
Stability	
Offset	$\pm 25\text{ppm}/^\circ\text{C}$
Gain	$\pm 50\text{ppm}/^\circ\text{C}$
Noise	
Output, 100kHz	250 μVrms
Bandwidth, -3dB	3Hz
Response Time, 90% Span	150ms
Output Range	0V to +5V
Output Protection	Continuous Short to Ground
Transient	ANSI/IEEE C37.90.1
Power Supply Voltage	+5VDC $\pm 5\%$
Power Supply Current	30mA
Power Supply Sensitivity	$\pm 75\text{ppm}/\%$
Mechanical Dimensions (h)(w)(d)	1.11" x 1.65" x 0.40" (28.1mm x 41.9mm x 10.2mm)
Environmental	
Operating Temperature Range	-40°C to +85°C
Storage Temperature Range	-40°C to +85°C
Relative Humidity	0 to 95% Noncondensing
Emissions EN61000-6-4	ISM, Group 1
Radiated, Conducted	Class A
Immunity EN61000-6-2	ISM, Group 1
RF	Performance A $\pm 0.5\%$ Span Error
ESD, EFT	Performance B

NOTES:

(1) Includes linearity, hysteresis and repeatability.

Ordering Information

Model	Input Range	Output Range
8B32-01	4mA to 20mA	0V to +5V
8B32-02	0mA to 20mA	0V to +5V