



# 8B39

## Current Output Modules

### Description

8B modules are an optimal solution for monitoring real-world process signals and providing high-level signals to a data acquisition system. Each 8B39 module accepts an input signal from a non-isolated source, then isolates, filters, and converts the signal to an analog process current output.

Signal filtering is accomplished with a 3-pole filter optimized for time and frequency response which provides 60dB per decade of normal-mode rejection above 100Hz. One pole of this filter is on the system side and the other two are on the isolated field side.

A special output circuit in the 8B39 module provides protection against accidental connection of power-line voltages up to 40VAC continuous. Clamp circuits on the I/O and power terminals protect against harmful transients.

The modules are designed for installation in Class I, Division 2 hazardous locations and have a high level of immunity to environmental noise.

### ► Features

- Accepts High-Level Voltage or Process Current Input
- Process Current Output
- 1500Vrms Isolation
- ANSI/IEEE C37.90.1 Transient Protection
- Output Protection to 40VAC Continuous
- 110dB CMR
- 100Hz Signal Bandwidth
- ±0.05% Accuracy
- ±0.02% Linearity
- Low Drift with Ambient Temperature
- CE Compliant
- C-UL-US Listed
- ATEX Compliance Pending
- Mix and Match Module Types on Backpanel

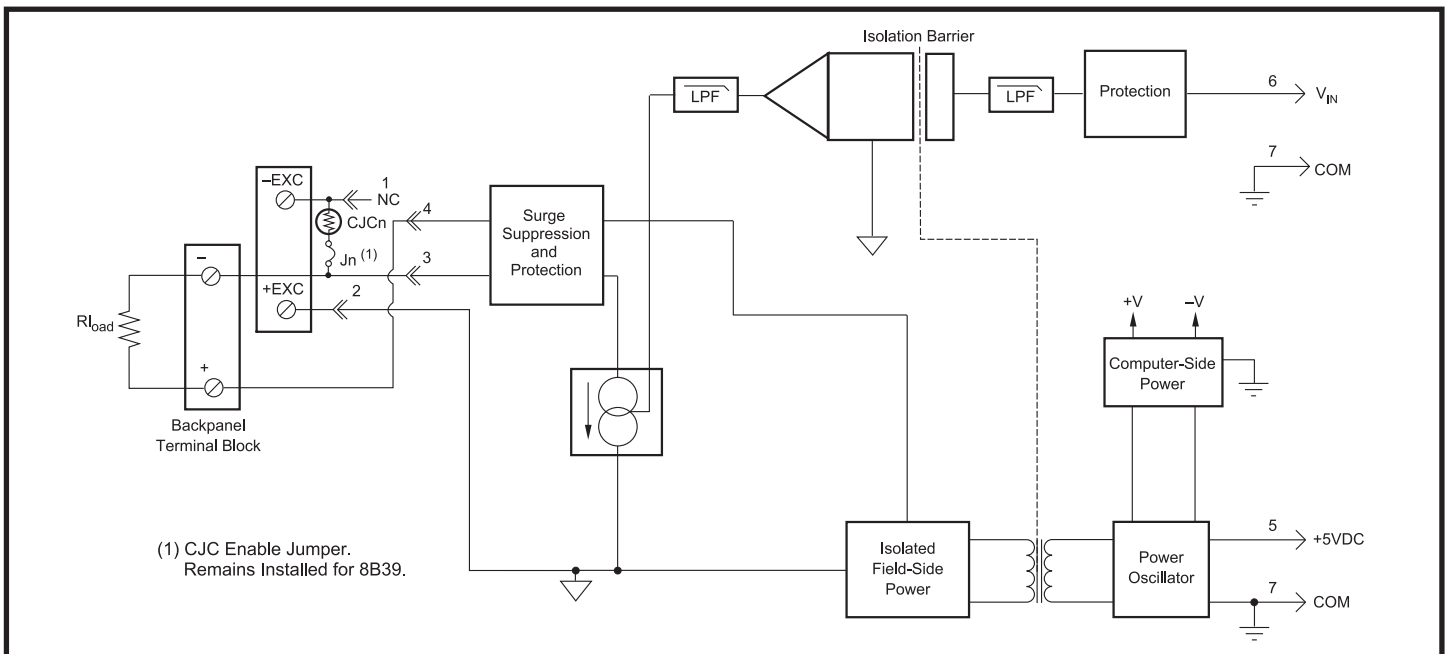

Figure 1: 8B39 Block Diagram

**Specifications** Typical at  $T_A=+25^{\circ}\text{C}$  and +5V power

Module	8B39-01,-02,-03,-04	8B39-07
Input Voltage Range	$\pm 5\text{V}$ or $0\text{V}$ to $+5\text{V}$	$\pm 5\text{V}$
Input Voltage Maximum	$\pm 20\text{V}$ (no damage)	*
Input Resistance	$50\text{M}\Omega$	*
Output Current Range	0 to $20\text{mA}$ or 4 to $20\text{mA}$	$\pm 20\text{mA}$
Over Range Capability	10%	*
Output Compliance Voltage (Open Circuit)	15VDC	$\pm 12\text{VDC}$
Load Resistance Range	0 to $500\Omega$	0 to $400\Omega$
Output I Under Fault, max	$26\text{mA}$	$\pm 26\text{mA}$
Output Protection		
Continuous	40VAC	*
Transient	ANSI/IEEE C37.90.1	*
CMV, Output to Input	1500Vrms max	*
Transient, Output to Input	ANSI/IEEE C37.90.1	*
CMR (50Hz or 60Hz)	110dB	*
NMR (-3dB at 100Hz)	60dB per decade above 100Hz	*
Accuracy <sup>(1)</sup>	$\pm 0.05\%$ Span	*
Linearity	$\pm 0.02\%$ Span	*
Stability		
Offset	$\pm 10\text{ppm}/^{\circ}\text{C}$	*
Gain	$\pm 50\text{ppm}/^{\circ}\text{C}$	$\pm 100\text{ppm}/^{\circ}\text{C}$
Noise		
Output, 100kHz	$2\mu\text{Arms}$	*
Bandwidth, -3dB	100Hz	*
Rise Time, 10 to 90% Span	5ms	*
Power Supply Voltage	+5VDC $\pm 5\%$	*
Power Supply Current	100mA	*
Power Supply Sensitivity	$\pm 100\text{ppm}/\%$	*
Mechanical Dimensions (h)(w)(d)	1.11" x 1.65" x 0.40" (28.1mm x 41.9mm x 10.2mm)	*
Environmental		
Operating Temperature Range	$-40^{\circ}\text{C}$ to $+85^{\circ}\text{C}$	*
Storage Temperature Range	$-40^{\circ}\text{C}$ to $+85^{\circ}\text{C}$	*
Relative Humidity	0 to 95% Noncondensing	*
Emissions EN61000-6-4	ISM, Group 1	*
Radiated, Conducted	Class A	*
Immunity EN61000-6-2	ISM, Group 1	*
RF	Performance A $\pm 0.5\%$ Span Error	*
ESD, EFT	Performance B	*

**NOTES:**

\* Same specification as -01, -02, -03, -04 models.

(1) Includes linearity, hysteresis and repeatability.

**Ordering Information**

Model	Input Range	Output Range
8B39-01	0V to +5V	4mA to 20mA
8B39-02	-5V to +5V	4mA to 20mA
8B39-03	0V to +5V	0mA to 20mA
8B39-04	-5V to +5V	0mA to 20mA
8B39-07	-5V to +5V	-20mA to +20mA