



Main Features

- 15" 4:3 XGA (1024 x 768) TFT LCD panel
- 15" projected capacitive true flat touch screen
- Fanless POS terminal
- Intel® Atom™ D525 Dual-Core processor, 1.8GHz
- Support DDR3 SO-DIMM memory
- 2.5" removable SATA HDD
- Powered COM(4), USB(4), printer port(1), VGA(1), GbE LAN(1), cash drawer(1)
- Front bezel complies with IP-65 protection standard
- Optional kits for MSR/ fingerprint/ VFD
- Optional VESA 100x 100mm mounting for wall-mount application

Product Overview

The NPT 1552 is a high value Point-of-Sale (POS) hardware solution to fulfill your POS hardware requirement. The stylish zero bezel design makes it easy for your POS terminal to fit the modern store design. Projected capacitive touch screen is the best reliable solution, and minimizes service efforts on touch screen.

The fanless design is noise-free, features low power consumption, and requires minimal maintenance. Removable HDD, MSR, fingerprint and VFD kit design provides an easy maintenance method, which saves your service cost. The +12VDC output provides sufficient power for your 2nd display from POS terminal, which offers better cable routing and high-integration for 2nd display. Small footprint is ideal for installations where space is compact in stores. The VESA mounting design of display head, 100x 100mm, provides an option for wall-mounting application when detaching the stand of terminal. The design offers a spill resistant and high integration for POS peripherals, which provides restaurant and retail conditions with continuous operation.

Specifications

Panel

- LCD Size: 15", 4:3
- Resolution: XGA 1024 x 768
- Luminance: 250cd/m²
- Contrast ratio: 700
- LCD color: 16.2M
- Viewing angle: 80 (upper), 80 (lower), 85 (left), 85 (right)
- Backlight: CCFL
- Touch screen: projected capacitive true flat (zero bezel)
- Touch light transmission: 91%
- Touch interface: USB

System

- CPU: Intel® Atom™ D525, 1.8GHz
- BIOS: AMI BIOS
- System chipset: Intel® ICH8M
- System memory: 1x 204-pin DDR3 SO-DIMM socket, 2GB DDR3 (default), optional support up to 4GB DDR3 800, Non-ECC and Un-buffered
- Hard disk drive: one 2.5" 160GB SATA HDD, removable type
- Expansion: 1 x Mini-card socket for Mini-PCIe and USB interface

Rear I/O

- USB: 4x USB2.0 port
- COM: 4x DB-9 powered RS-232 port, adjust RI/ 5V/ 12V by BIOS setting
- Ethernet: 1x RJ-45, 10/100/1000 Mbps
- VGA: 1x DB-15 2nd VGA port
- Cash drawer: 1x RJ-11 port, support two cash drawers (24V, Max 1.1A)
- Parallel: 1x DB-25 printer port
- Audio: 1x Line-out jack
- DC-IN: 1x +12VDC input, Mini-DIN 4 pin lock type
- DC-OUT: 1x +12VDC output for 2nd display power (12V, Max 3.0A)

Audio

- High Definition audio codec: Realtek ALC886-GR
- Internal audio: one 3W speaker
- External audio: Line-out audio jack

Ethernet

- LAN chip: Realtek® RTL8111C-VC-GR Gigabit LAN
- Ethernet interface: 10/100/1000 Based-TX Ethernet compatible

Dimension Drawing

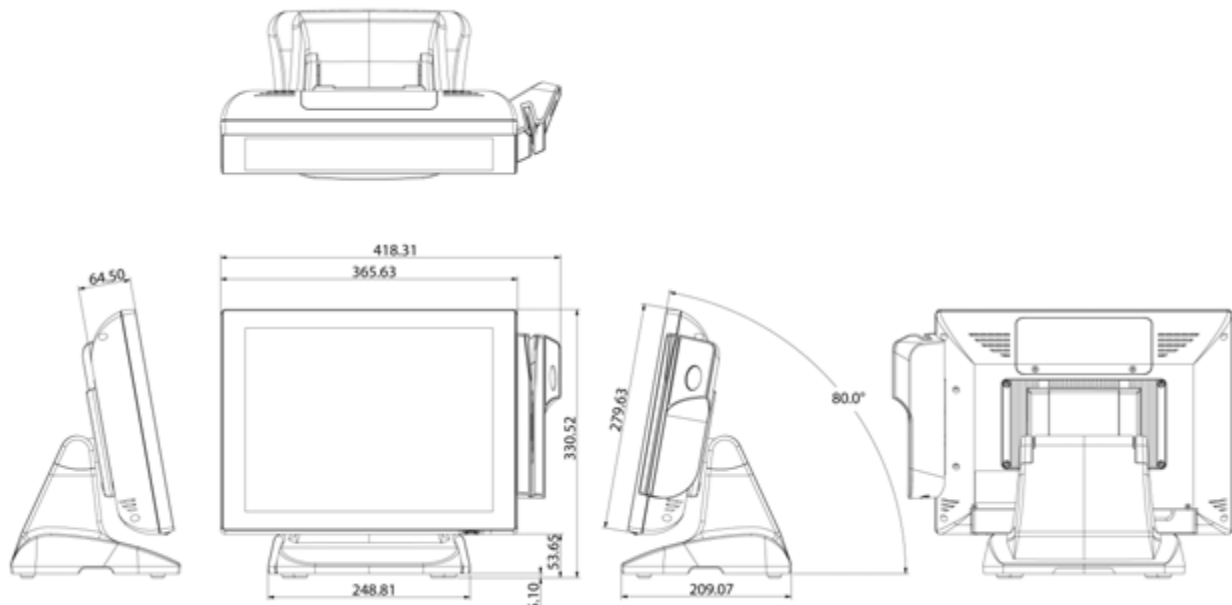

Mechanical & Environment

- Color: Beige
- Mounting: desktop type, optional VESA 100 x 100mm wall-mount when detaching stand
- IP protection: front bezel complies with IP-65 protection standard
- Power input: +12VDC
- Power adapter: AC to DC power brick (+12VDC/ 8.33A, 100W)
- Operating temperature: 0°C to 40°C
- Storage temperature: -20°C to 60°C
- Operating humidity: 20%~80% relative humidity, non-condensing
- Dimension: 366mm (W) x 331mm (H) x 210mm (D) (no MSR), 419mm (W) x 331mm (H) x 210mm (D) (with MSR)
- Weight: 8.5kg
- Tilt angle: 0° ~ 80°

Certifications

- CE approval
- FCC Class A

Ordering Information

◆ NPT 1552-110 (P/N: A0Y00155205X0)

- CPU: Intel® Atom™ D525, Dual-Core 1.8GHz L2 1MB;
- LCD/ Touch: 15" XGA 1024 x 768 250nits/ projected capacitive true flat touch;
- Memory: 2GB DDR3 SO-DIMM;
- HDD: 160GB 2.5" SATA 5,400rpm;
- Power: +12VDC/ 100W power brick