



NEXCOM International Co., Ltd.

Mobile Computing Solutions

Vehicle Mount Computer

VMC 100/1100 Series

User Manual

CONTENTS

Preface

Copyright	v
Disclaimer	v
Acknowledgements	v
Regulatory Compliance Statements	v
Declaration of Conformity.....	v
RoHS Compliance	vi
Warranty and RMA	vii
Safety Information	viii
Installation Recommendations.....	viii
Safety Precautions.....	ix
Technical Support and Assistance.....	x
Conventions Used in this Manual.....	x
Global Service Contact Information.....	xi
Headquarters.....	xi
Package Contents.....	xiii
Ordering Information	xiv

Chapter 1: Product Introduction

Overview	1
VMC 100 Key Features	1
VMC 1100 Key Features	2
Hardware Specifications.....	4
VMC 100	4

VMC 1100	6
Mechanical Dimensions.....	8
VMC 100 Series.....	8
VMC 1100 Series.....	9
Getting to Know VMC 100/1000 Series	10
VMC 100/1100 Series Front & Side View	10
VMC 100/1100 Series Rear View	11

Chapter 2: Using the GPS Feature

Setup and Using GPS Information	16
Setup Window Screenshot	17
GPS Info Window Screenshot.....	18
GPS Information Instructions	19

Chapter 3: Jumpers and Connectors

Before You Begin	20
Precautions	20
Jumper	21
Locations of the Jumpers and Connectors.....	22
Mainboard	22
Internal Connectors and DIP Switch Settings	23
VGA Connector	23
Flash/Debug Connector	23
MCU Debug COM Header	24
MCU Flash Connector	24

- EC Debug COM Connector25
- Port 80 Debug Connector25
- Serial-ATA26
- SATA DOM Power Connector26
- ME/RTC Clear Switch27
- Input Voltage Control Switch.....27
- GPIO Pull High Switch28
- LED Indicators28
- External Connectors.....29
 - RS232 Connector.....29
 - RS485/CAN Connector.....29
 - GPIO and Sensor Connector.....30

Chapter 4: Function Key Code Constants

- Visual Basic Reference.....31
- Extended ASCII Keyboard Codes32

Chapter 5: Touchscreen Installation Guide

- 5.1 Install PenMount Windows Universal Driver
(for 2000/XP/XPT/XPE/2003/VISTA/7/WES7/2008/8).....34
 - 5.1.1 Install PenMount Mouse Driver in Windows
2000/XP/XPT/XPE/2003/VISTA/7/WES7/2008/8.....36
 - 5.1.2 Install PenMount Digitizer Driver in Windows
XPT/VISTA/7/WES7/2008/8.....37
 - 5.1.3 Configure Touchscreen In PenMount mouse driver.....37
 - 5.1.4 PenMount Control Panel38
 - 5.1.5 PenMount Monitor Menu Icon42
 - 5.1.6 PenMount Rotating Function.....42
 - 5.1.7 The Touchscreen Configure of PenMount Digitizer Driver.....43
 - 5.1.7.1 PenMount Control Panel44
 - 5.1.8 Uninstall PenMount Windows Universal Driver.....47

- 5.2 Install PenMount Linux X Window USB Driver48
 - 5.2.1 Install PenMount Linux X Window USB Driver.....48
 - 5.2.2 Calibration Utilities48
- 5.3 Install PenMount WinCE Driver49
 - 5.3.1 Install PenMount WinCE Driver.....49

Chapter 6: Touchscreen Driver Software Functions

- 6.1 Standard Calibration52
- 6.2 Advanced Calibration.....52
- 6.3 Rotation.....52
- 6.4 Draw52
- 6.5 Mouse Operation Mode.....54
- 6.6 Beep Sound54
- 6.7 Beep Sound Adjustable54
- 6.8 Wake Up Function54
- 6.9 Plot Calibration Data.....54
- 6.10 Right Button54
- 6.11 Hide Cursor54
- 6.12 Cursor Offset.....55
- 6.13 Double Click Area and Speed.....55
- 6.14 About.....55
- 6.15 Edge Compensation.....55
- 6.16 Refresh55

Chapter 7: PenMount Gesture AP for Windows

- 7.1 Invoke PenMount Gesture AP57
- 7.2 Configure PenMount Gesture AP.....58
- 7.3 PenMount Gestures' Default Values in Windows XP.....60

Chapter 8: Enable a Hibernate Once/Resume Many

- Environment by Using EWF61

Chapter 9:	
How to Install the WWAN or Wi-Fi Module.....	62
Chapter 10: How to Install a SATA DOM Module	63
Chapter 11: Installing the OBD Module	66
Appendix A: I/O Address Function	69
Appendix B: Vehicle Power Management Setup.....	86
Appendix C: SMS and Dial Wake-up Setting	93
Appendix D: RTC Wake-up Setting	94
Appendix E: Auto Backlight Setting	96
Appendix F: BIOS Update	97

PREFACE

Copyright

This publication, including all photographs, illustrations and software, is protected under international copyright laws, with all rights reserved. No part of this manual may be reproduced, copied, translated or transmitted in any form or by any means without the prior written consent from NEXCOM International Co., Ltd.

Disclaimer

The information in this document is subject to change without prior notice and does not represent commitment from NEXCOM International Co., Ltd. However, users may update their knowledge of any product in use by constantly checking its manual posted on our website: <http://www.nexcom.com>. NEXCOM shall not be liable for direct, indirect, special, incidental, or consequential damages arising out of the use of any product, nor for any infringements upon the rights of third parties, which may result from such use. Any implied warranties of merchantability or fitness for any particular purpose is also disclaimed.

Acknowledgements

VMC 100 and VMC 1100 are trademarks of NEXCOM International Co., Ltd. All other product names mentioned herein are registered trademarks of their respective owners.

Regulatory Compliance Statements

This section provides the FCC compliance statement for Class A devices and describes how to keep the system CE compliant.

Declaration of Conformity

FCC

This equipment has been tested and verified to comply with the limits for a Class A digital device, pursuant to Part 15 of FCC Rules. These limits are designed to provide reasonable protection against harmful interference when the equipment is operated in a commercial environment. This equipment generates, uses, and can radiate radio frequency energy and, if not installed and used in accordance with the instructions, may cause harmful interference to radio communications. Operation of this equipment in a residential area (domestic environment) is likely to cause harmful interference, in which case the user will be required to correct the interference (take adequate measures) at their own expense.

CE

The product(s) described in this manual complies with all applicable European Union (CE) directives if it has a CE marking. For computer systems to remain CE compliant, only CE-compliant parts may be used. Maintaining CE compliance also requires proper cable and cabling techniques.

RoHS Compliance

NEXCOM RoHS Environmental Policy and Status Update



NEXCOM is a global citizen for building the digital infrastructure. We are committed to providing green products and services, which are compliant with European Union RoHS (Restriction on Use of Hazardous Substance in Electronic Equipment) directive 2011/65/EU, to be your trusted green partner and to protect our environment.

RoHS restricts the use of Lead (Pb) < 0.1% or 1,000ppm, Mercury (Hg) < 0.1% or 1,000ppm, Cadmium (Cd) < 0.01% or 100ppm, Hexavalent Chromium (Cr6+) < 0.1% or 1,000ppm, Polybrominated biphenyls (PBB) < 0.1% or 1,000ppm, and Polybrominated diphenyl Ethers (PBDE) < 0.1% or 1,000ppm.

In order to meet the RoHS compliant directives, NEXCOM has established an engineering and manufacturing task force in to implement the introduction of green products. The task force will ensure that we follow the standard NEXCOM development procedure and that all the new RoHS components and new manufacturing processes maintain the highest industry quality levels for which NEXCOM are renowned.

The model selection criteria will be based on market demand. Vendors and suppliers will ensure that all designed components will be RoHS compliant.

How to recognize NEXCOM RoHS Products?

For existing products where there are non-RoHS and RoHS versions, the suffix "(LF)" will be added to the compliant product name.

All new product models launched after January 2013 will be RoHS compliant. They will use the usual NEXCOM naming convention.

Warranty and RMA

NEXCOM Warranty Period

NEXCOM manufactures products that are new or equivalent to new in accordance with industry standard. NEXCOM warrants that products will be free from defect in material and workmanship for 2 years, beginning on the date of invoice by NEXCOM. HCP series products (Blade Server) which are manufactured by NEXCOM are covered by a three year warranty period.

NEXCOM Return Merchandise Authorization (RMA)

- ❌ Customers shall enclose the “NEXCOM RMA Service Form” with the returned packages.
- ❌ Customers must collect all the information about the problems encountered and note anything abnormal or, print out any on-screen messages, and describe the problems on the “NEXCOM RMA Service Form” for the RMA number apply process.
- ❌ Customers can send back the faulty products with or without accessories (manuals, cable, etc.) and any components from the card, such as CPU and RAM. If the components were suspected as part of the problems, please note clearly which components are included. Otherwise, NEXCOM is not responsible for the devices/parts.
- ❌ Customers are responsible for the safe packaging of defective products,

making sure it is durable enough to be resistant against further damage and deterioration during transportation. In case of damages occurred during transportation, the repair is treated as “Out of Warranty.”

- ❌ Any products returned by NEXCOM to other locations besides the customers’ site will bear an extra charge and will be billed to the customer.

Repair Service Charges for Out-of-Warranty Products

NEXCOM will charge for out-of-warranty products in two categories, one is basic diagnostic fee and another is component (product) fee.

System Level

- ❌ Component fee: NEXCOM will only charge for main components such as SMD chip, BGA chip, etc. Passive components will be repaired for free, ex: resistor, capacitor.
- ❌ Items will be replaced with NEXCOM products if the original one cannot be repaired. Ex: motherboard, power supply, etc.
- ❌ Replace with 3rd party products if needed.
- ❌ If RMA goods can not be repaired, NEXCOM will return it to the customer without any charge.

Board Level

- ✘ Component fee: NEXCOM will only charge for main components, such as SMD chip, BGA chip, etc. Passive components will be repaired for free, ex: resistors, capacitors.

If RMA goods can not be repaired, NEXCOM will return it to the customer without any charge.

Warnings

Read and adhere to all warnings, cautions, and notices in this guide and the documentation supplied with the chassis, power supply, and accessory modules. If the instructions for the chassis and power supply are inconsistent with these instructions or the instructions for accessory modules, contact the supplier to find out how you can ensure that your computer meets safety and regulatory requirements.

Cautions

Electrostatic discharge (ESD) can damage system components. Do the described procedures only at an ESD workstation. If no such station is available, you can provide some ESD protection by wearing an antistatic wrist strap and attaching it to a metal part of the computer chassis.

Safety Information

Before installing and using the device, note the following precautions:

- Read all instructions carefully.
- Do not place the unit on an unstable surface, cart, or stand.
- Follow all warnings and cautions in this manual.

- When replacing parts, ensure that your service technician uses parts specified by the manufacturer.
- Avoid using the system near water, in direct sunlight, or near a heating device.
- The load of the system unit does not solely rely for support from the rackmounts located on the sides. Firm support from the bottom is highly necessary in order to provide balance stability.

The computer is provided with a battery-powered real-time clock circuit. There is a danger of explosion if battery is incorrectly replaced. Replace only with the same or equivalent type recommended by the manufacturer. Discard used batteries according to the manufacturer's instructions.

Installation Recommendations

Ensure you have a stable, clean working environment. Dust and dirt can get into components and cause a malfunction. Use containers to keep small components separated.

Adequate lighting and proper tools can prevent you from accidentally damaging the internal components. Most of the procedures that follow require only a few simple tools, including the following:

- A Philips screwdriver
- A flat-tipped screwdriver
- A grounding strap
- An anti-static pad

Using your fingers can disconnect most of the connections. It is recommended that you do not use needlenose pliers to disconnect connections as these can damage the soft metal or plastic parts of the connectors.

Safety Precautions

1. Read these safety instructions carefully.
2. Keep this User Manual for later reference.
3. Disconnect this equipment from any AC outlet before cleaning. Use a damp cloth. Do not use liquid or spray detergents for cleaning.
4. For plug-in equipment, the power outlet socket must be located near the equipment and must be easily accessible.
5. Keep this equipment away from humidity.
6. Put this equipment on a stable surface during installation. Dropping it or letting it fall may cause damage.
7. Do not leave this equipment in either an unconditioned environment or in a above 40°C storage temperature as this may damage the equipment.
8. The openings on the enclosure are for air convection to protect the equipment from overheating. DO NOT COVER THE OPENINGS.
9. Make sure the voltage of the power source is correct before connecting the equipment to the power outlet.
10. Place the power cord in a way so that people will not step on it. Do not place anything on top of the power cord. Use a power cord that has been approved for use with the product and that it matches the voltage and current marked on the product's electrical range label. The voltage and current rating of the cord must be greater than the voltage and current rating marked on the product.
11. All cautions and warnings on the equipment should be noted.
12. If the equipment is not used for a long time, disconnect it from the power source to avoid damage by transient overvoltage.
13. Never pour any liquid into an opening. This may cause fire or electrical shock.
14. Never open the equipment. For safety reasons, the equipment should be opened only by qualified service personnel.
15. If one of the following situations arises, get the equipment checked by service personnel:
 - a. The power cord or plug is damaged.
 - b. Liquid has penetrated into the equipment.
 - c. The equipment has been exposed to moisture.
 - d. The equipment does not work well, or you cannot get it to work according to the user's manual.
 - e. The equipment has been dropped and damaged.
 - f. The equipment has obvious signs of breakage.
16. Do not place heavy objects on the equipment.
17. The unit uses a three-wire ground cable which is equipped with a third pin to ground the unit and prevent electric shock. Do not defeat the purpose of this pin. If your outlet does not support this kind of plug, contact your electrician to replace your obsolete outlet.
18. **CAUTION:** DANGER OF EXPLOSION IF BATTERY IS INCORRECTLY REPLACED. REPLACE ONLY WITH THE SAME OR EQUIVALENT TYPE RECOMMENDED BY THE MANUFACTURER. DISCARD USED BATTERIES ACCORDING TO THE MANUFACTURER'S INSTRUCTIONS.
19. The computer is provided with CD drives that comply with the appropriate safety standards including IEC 60825.

Technical Support and Assistance

1. For the most updated information of NEXCOM products, visit NEXCOM's website at www.nexcom.com.
2. For technical issues that require contacting our technical support team or sales representative, please have the following information ready before calling:
 - Product name and serial number
 - Detailed information of the peripheral devices
 - Detailed information of the installed software (operating system, version, application software, etc.)
 - A complete description of the problem
 - The exact wordings of the error messages

Warning!

1. Handling the unit: carry the unit with both hands and handle it with care.
2. Maintenance: to keep the unit clean, use only approved cleaning products or clean with a dry cloth.
3. CompactFlash: Turn off the unit's power before inserting or removing a CompactFlash storage card.

Conventions Used in this Manual



Warning:

Information about certain situations, which if not observed, can cause personal injury. This will prevent injury to yourself when performing a task.



Caution:

Information to avoid damaging components or losing data.



Note:

Provides additional information to complete a task easily.

Battery - Safety Measures

Caution

- Risk of explosion if battery is replaced by an incorrect type.
- Dispose of used batteries according to the instructions.

Safety Warning



This equipment is intended for installation in a Restricted Access Location only.

Resetting the Date and Time



Note: Remember to reset the date and time upon receiving the product. You can set them in the AMI BIOS. Refer to chapter 4 for more information.

Global Service Contact Information

Headquarters

NEXCOM International Co., Ltd.

15F, No. 920, Chung-Cheng Rd.,
ZhongHe District, New Taipei City, 23586,
Taiwan, R.O.C.

Tel: +886-2-8226-7786

Fax: +886-2-8226-7782

www.nexcom.com

America

USA

NEXCOM USA

2883 Bayview Drive,
Fremont CA 94538, USA

Tel: +1-510-656-2248

Fax: +1-510-656-2158

Email: sales@nexcom.com

www.nexcom.com

Asia

Taiwan

NEXCOM Intelligent Systems

Taipei Office

13F, No.920, Chung-Cheng Rd.,
ZhongHe District,
New Taipei City, 23586, Taiwan, R.O.C.

Tel: +886-2-8226-7796

Fax: +886-2-8226-7792

Email: sales@nexcom.com.tw

www.nexcom.com.tw

NEXCOM Intelligent Systems

Taichung Office

16F, No.250, Sec. 2, Chongde Rd.,
Beitun Dist.,

Taichung City 406, R.O.C.

Tel: +886-4-2249-1179

Fax: +886-4-2249-1172

Email: sales@nexcom.com.tw

www.nexcom.com.tw

Japan

NEXCOM Japan

9F, Tamachi Hara Bldg.,
4-11-5, Shiba Minato-ku,
Tokyo, 108-0014, Japan

Tel: +81-3-5419-7830

Fax: +81-3-5419-7832

Email: sales@nexcom-jp.com

www.nexcom-jp.com

China

NEXCOM China

1F & 2F, Block A, No. 16 Yonyou Software Park,
No. 68 Beiqing Road, Haidian District,
Beijing, 100094, China

Tel: +86-010-5704-2680

Fax: +86-010-5704-2681

Email: sales@nexcom.cn

www.nexcom.cn

Chengdu Office

9F, Shuxiangxie, Xuefu Garden,
No.12 Section 1, South Yihuan Rd.,
Chengdu, 610061, China
Tel: +86-28-8523-0186
Fax: +86-28-8523-0186
Email: sales@nexcom.cn
www.nexcom.cn

Shanghai Office

Room 603/604, Huiyinmingzun Plaza Bldg., 1,
No.609, Yunlin East Rd.,
Shanghai, 200333, China
Tel: +86-21-5278-5868
Fax: +86-21-3251-6358
Email: sales@nexcom.cn
www.nexcom.cn

Shenzhen Office

Room1707, North Block, Pines Bldg.,
No.7 Tairan Rd., Futian Area,
Shenzhen, 518040, China
Tel: +86-755-8332-7203
Fax: +86-755-8332-7213
Email: sales@nexcom.cn
www.nexcom.cn

Wuhan Office

1-C1804/1805, Mingze Liwan, No. 519
South Luoshi Rd., Hongshan District,
Wuhan, 430070, China
Tel: +86-27-8722-7400
Fax: +86-27-8722-7400
Email: sales@nexcom.cn
www.nexcom.cn

Europe

United Kingdom

NEXCOM EUROPE

10 Vincent Avenue,
Crownhill Business Centre,
Milton Keynes, Buckinghamshire
MK8 0AB, United Kingdom
Tel: +44-1908-267121
Fax: +44-1908-262042
Email: sales.uk@nexcom.eu
www.nexcom.eu

Italy

NEXCOM ITALIA S.r.l

Via Lanino 42,
21047 Saronno (VA), Italia
Tel: +39 02 9628 0333
Fax: +39 02 9625570
Email: nexcomitalia@nexcom.eu
www.nexcomitalia.it

Package Contents

Before continuing, verify that the package that you received is complete. Your package should have all the items listed in the following table.

VMC 100

Item	P/N	Name	Specification	Qty
1	6030000084X00	DB15 Male to Open Cable	VGA 15P/M to Open L=150mm	1
2	50311F0495X00	P Head Screw w/Spring+Flat Washer	P5x14 ISO/SW10x1 NI	6
3	603POW0087X00	Waterproof Power Cable	Waterproof M10.5 5PIN Open L=130mm	1
4	603ANT0055X00	GPS/GLONASS Antenna	SMA Male L=5000mm	1
5		VMC Series DVD Driver		1

VMC 1100

Item	P/N	Name	Specification	Qty
1	6030000084X00	DB15 Male to Open Cable	VGA 15P/M TO Open L=150mm	1
2	50311F0495X00	P Head Screw w/Spring+Flat Washer	P5x14 ISO/SW10x1 NI	6
3	603POW0087X00	Waterproof Power Cable	Waterproof M10.5 5PIN OPEN L=130mm	1
4	603ANT0055X00	GPS/GLONASS Antenna	SMA Male L=5000mm	1
5	5060200193X00	Thermal Pad	40x20x3.5t mm S3S K=2.0w/mk	1
6	5061100057X00	VMC 1100 SATA DOM Sponge	30x7mm 3.65T EVA Black	1
7	603POW0086X00	SATA-DOM Power Cable	A1251 2P TO A1254 3P L=70mm	1
8		VMC Series DVD Driver		1

Ordering Information

The following provides ordering information.

- **VMC 100-A1U (P/N: 10VC0010000X0)**
 - VMC 100-A1U 7" vehicle mount computer w/ TI 3352, 256MB, 4w T/S, Linux
- **VMC 1100 (P/N: 10VC0110000X0)**
 - VMC 1100 7" vehicle mount computer w/ Intel® Atom™ E3825, 2GB, 4w T/S

CHAPTER 1: PRODUCT INTRODUCTION

Overview



VMC 100 Front View



VMC 100 Rear View

VMC 100 Key Features

- 7" WVGA TFT LCD monitor with resistor touch screen
- ARM® Cortex™-A8 Processor with 800MHz frequency
- Compact and fanless design
- On screen F1~F5 function key
- Support Linux and Android system
- Built-in GPS (Optional: Dead Reckoning Support)
- Variety of wireless communication options (Support LTE)
- Dual CAN bus support and optional OBDII (SAE J1939)
- Wide range DC input from 9~36V
- SAE J1113, ISO7637-2 and SAE J1455 compliance for power design



VMC 1100 Front View



VMC 1100 Rear View

VMC 1100 Key Features

- 7" WVGA TFT LCD monitor with resistor touch screen
- Built-in Intel® Atom™ Dual Core E3825 1.33GHz
- Compact and fanless design
- On screen F1~F5 function key
- Support GPS/GPRS/GSM tracker function
- Built-in GPS (Optional: Dead Reckoning Support)
- Variety of wireless communication options (Support LTE)
- Dual CAN bus support and optional OBDII (SAE J1939)
- Wide range DC input from 9~36V
- SAE J1113, ISO7637-2 and SAE J1455 compliance for power design

VMC 100, a 7-inch all in one vehicle computer, is designed for the cost-effective solution for transportation application. Same as all VMC series, the fanless and wide temperature support are reserved in VMC 100 design. VMC 100 adopts Linux and Android system with Cortex™-A8 processor, it integrates a high resolution LCD with a brightness of 400 nits and 4-wire resistive touch sensor. VMC 100 is equipped with Bluetooth, Wi-Fi and WWAN for optional connection capability for real-time communication. It provides RS-232/422/485, USB 2.0, GPIO and LAN signal to link with peripherals. Its mounting hole is compatible with VESA75 and can be installed in vehicles with limited space via RAM mount kits.

VMC 1100, a new generation 7-inch vehicle mount computer with dual core Intel® Atom™ processor, is designed for transportation applications requiring real-time vehicle tracking. Adopting the latest low power consumption processor and integrating a WVGA LCD with a brightness of 400nits and a 4-wire resistive touch sensor, VMC 1100 does not compromise with its space to sacrifice its functional features. It provides dual CANbus, RS-232, RS-485, USB 3.0, GPIO, analog input, PWM and LAN signal. For security, VMC 1100 supports real-time vehicle tracking through GPS and SMS/GSM/GPRS. VMC 1100 can also be upgraded to a different LCD resolution and include other features such as LTE, projected capacitive touch, CANbus protocol support and backup battery.

Hardware Specifications

VMC 100

General

- Cooling System: Fanless
- Enclosure: Plastic PC + ABS
- Mounting: Support VESA 75, stand mounting
- Four SMA type antenna connectors of BT/ Wi-Fi/ WWAN/ GPS
- Power Input: 9~36VDC input with ignition
- Power Consumption: 15W
- Ingress Protection: Front panel IP54
- Dimension: 213mm (W) x 145mm (H) x 50mm (D)
(8.3" x 5.7" x 1.9")

LCD Panel

- 7-inch TFT LCD panel with LED backlight
- 800 x 480 pixels (WVGA)
- Brightness: 400 cd/m² (typical)
- Contrast ratio: 600:1 (typical)

Touch Screen Sensor

- 4-wire resistant touch
- Anti-glare coating surface
- Transmission rate: 78 ± 3%

CPU & Chipset

- ARM® Cortex™-A8 Processor with 720MHz

Memory

- Onboard DDR3 512MB

Expandable Storage

- 1x Micro SDHC Slot (Bundle with 8GB)

Expansion

- 1x Pin Head for WLAN option
- 1x Mini-PCIe socket ((USB + UART) for WWAN option)
- OBD option and SAE J1939 protocol support
- Battery module option

I/O Interfaces - Front

- F1~ F5 functions key
- Light sensor
- Internal mic-in
- 2x Built-in 2W speakers
- 3x LED indicators (Power mode, Storage and WWAN status)

I/O Interfaces - Lateral

Right side

- 1x Micro SD card socket
- 1x SIM card socket
- 1x USB 2.0 host type A connector
- 1x Mic-in, Line-out

Left side

- 1x Power button
- 1x System reset button
- Volume up/down or Brightness up/down

I/O Interface-Rear

- 1x 5pin circular connector for Power/Ignition input
- 1x RJ45 for LAN
- 1x RJ45 for full RS-232 with 0V/5V/12V power supply (0.5A)
- 1x DB9 (Male) for RX/TX or RS-485
- 2x CAN Bus 2.0
- 1x DB15 (Female) for GPS dead reckoning interface (optional)
- 3x GPO, 3x GPI

Communication Module

- 1x Onboard GPS module
- 1x WLAN or Bluetooth module for optional
- 1x WWAN module for optional

Power Management

- Selectable boot-up & shut-down voltage for low power protection
- HW design ready for 8-level delay time on/off at user's self configuration
- Power on/off ignition, software detectable

Operating System

- Linux Ubuntu (kernel V3.2.0)

Operating System

- Operating temperatures: Ambient with air -20°C to 70°C
- Storage temperatures: -30°C to 80°C
- Relative humidity: 10% to 90% (non-condensing)

- Vibration (random) : 3g @5~500Hz
- Vibration:
 - Operating: MIL-STD-810G, 514.6 Procedure 1, Category 4
 - Storage: MIL-STD-810G, 514.6 Procedure 1, Category 24
- Shock:
 - Operating: MIL-STD-810G, Method 516.6, Procedure I, trucks and semi-trailers= 20g
 - Crash hazard: MIL-STD-810G, Method 516.6, Procedure V, ground equipment= 75g

Power Design & Protection

- Load dump and inductive load protection
- Cold cranking protection
- Transient voltage protection
- Electrostatic discharge protection

Standards/Certifications

- EMC
 - CE, FCC class B
- Power
 - SAE J1113
 - SAE J1455
 - ISO 7637-2
- Safety
 - EN 60950-1 LVD

VMC 1100

General

- Cooling System: Fanless
- Enclosure: Plastic PC + ABS
- Mounting: Support VESA 75, stand mounting
- Four SMA type antenna connectors of BT/ Wi-Fi/ WWAN/ GPS
- Power Input: 9~36VDC input with ignition
- Power Consumption: 26W
- Ingress Protection: Front panel IP54
- Dimension: 213mm (W) x 145mm (H) x 50mm (D)
(8.3" x 5.7" x 1.9")

LCD Panel

- 7-inch TFT LCD panel with LED backlight
- 800 x 480 pixels (WVGA)
- Brightness: 400 cd/m² (typical)
- Contrast ratio: 600:1 (typical)

Touch Screen Sensor

- 4-wire resistant touch
- Anti-glare coating surface
- Transmission rate: 78 ± 3%

CPU & Chipset

- Intel® Atom™ Dual Core E3825 1.33GHz

Memory

- 2GB 204-pin DDR3L 1600MHz SO-DIMM slot (up to 4GB)

Expandable Storage

- 1x SATAIII SATA DOM Slot (available option 16GB, 32GB, 64GB and 128GB)

Expansion

- 1x Half Mini-PCIe socket (PCIe + USB) for WLAN option
- 1x Mini-PCIe socket ((USB + UART) for WWAN option)
- 1x External module for OBD SAE J1939 protocols/Battery module option (UART + USB)

I/O Interfaces - Front

- F1~ F5 functions key
- Light sensor
- Internal mic-in
- 2x Built-in 2W speakers
- 3x LED indicators (Power mode, Storage and WWAN status)

I/O Interfaces - Lateral

Right side

- 1x Micro SD card socket
- 1x SIM card socket
- 1x USB 3.0 host type A connector
- 1x Mic-in, Line-out

Left side

- 1x Power button
- 1x System reset button
- Volume up/down or Brightness up/down

I/O Interface-Rear

- 1x 5pin circular connector for Power/Ignition input
- 1x RJ45 for LAN
- 1x RJ45 for Full RS-232 with 0V/5V/12V power supply (0.5A)
- 1x DB9 (Male) for
 - RX/TX or RS-485
 - 1x CAN Bus 2.0
- 1x DB15 (Female) for
 - GPS dead reckoning interface (optional)
 - 2x PWM, 2x Analog Input, 3x GPO, 3x GPI
 Analog Input requirement for Voltages are measured
 Channel: 8
 Voltage range: 0~38V
 Resolution: 8 bit

Analog Input requirement for Frequency, Speed
 Square wave
 Frequency signal offset voltage range: 0~15VDC
 Protection: +/- 500V spike
 Frequency signal duty cycle range: 10%~90%

Communication Module

- 1x Onboard GPS module
- 1x WLAN or Bluetooth module for optional
- 1x WWAN module for optional

Power Management

- Selectable boot-up & shut-down voltage for low power protection
- HW design ready for 8-level delay time on/off at user's self configuration
- Power on/off ignition, software detectable
- Support S3 and S4 suspend mode; wake on RTC and SMS

Operating System

- Windows 8 Professional, WES8
- Windows 7, WES7
- Linux Fedora (kernel V3.2.0)

Operating System

- Operating temperatures: Ambient with air -20°C to 60°C
- Storage temperatures: -30°C to 80°C
- Relative humidity: 10% to 90% (non-condensing)
- Vibration (random): 3g @5~500Hz
- Vibration
 - Operating: MIL-STD-810G, 514.6 Procedure 1, Category 4
 - Storage: MIL-STD-810G, 514.6 Procedure 1, Category 24
- Shock
 - Operating: MIL-STD-810G, Method 516.6, Procedure I, trucks and semi-trailers= 20g
 - Crash hazard: MIL-STD-810G, Method 516.6, Procedure V, ground equipment= 75g

Power Design & Protection

- Load dump and inductive load protection
- Cold cranking protection
- Transient voltage protection
- Electrostatic discharge protection

Standards/Certifications

- EMC
 - CE, FCC class B
- Power
 - SAE J1113
 - SAE J1455
 - ISO 7637-2
- Safety
 - EN 60950-1 LVD

Mechanical Dimensions

VMC 100 Series

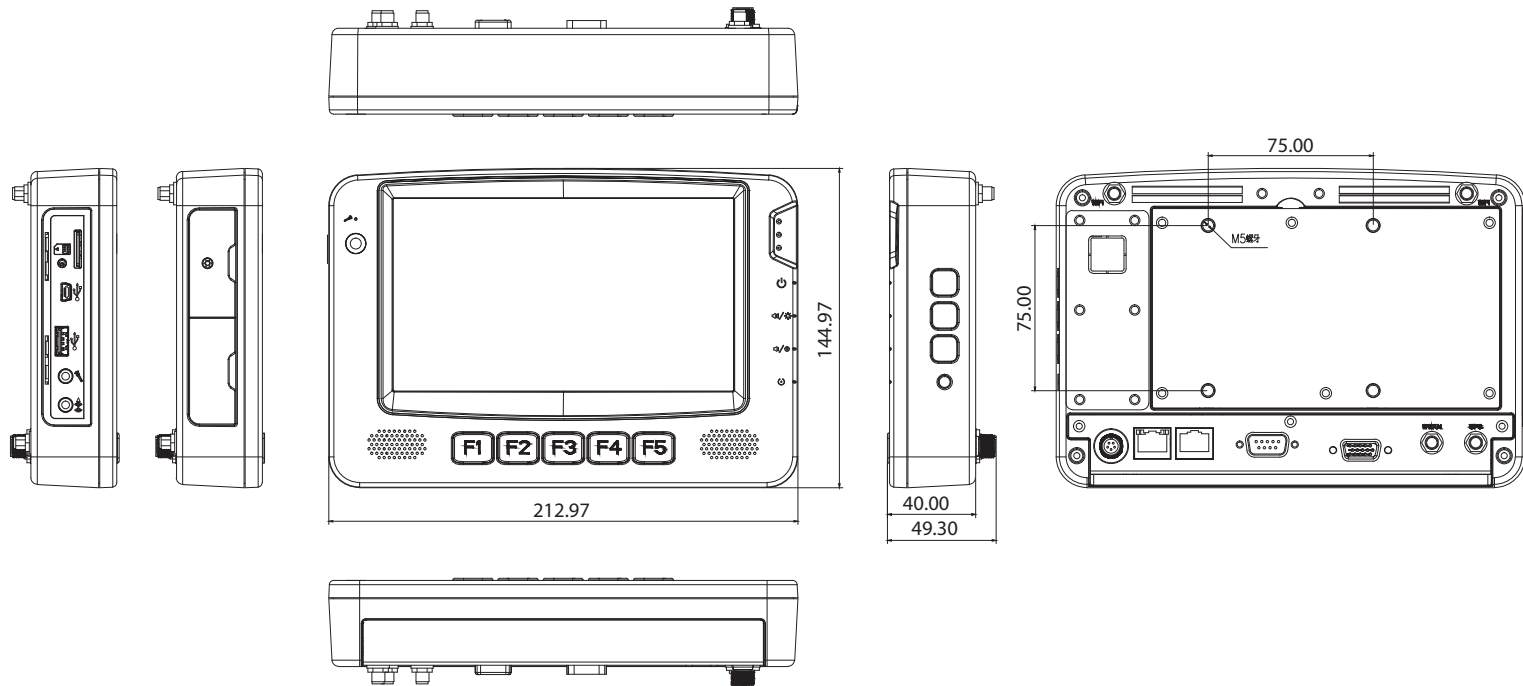

VMC 1100 Series

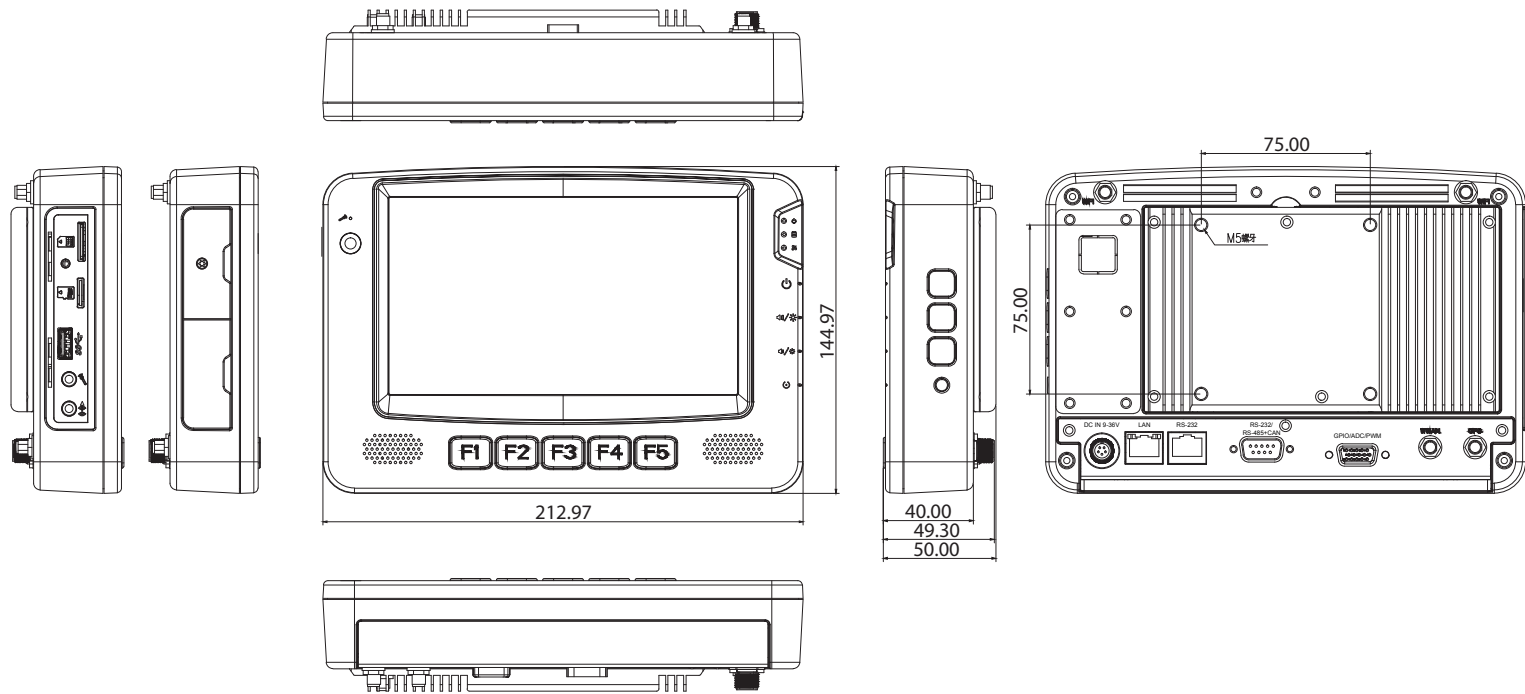

Getting to Know VMC 100/1000 Series

VMC 100/1100 Series Front & Side View



VMC 100/1100 Series Rear View

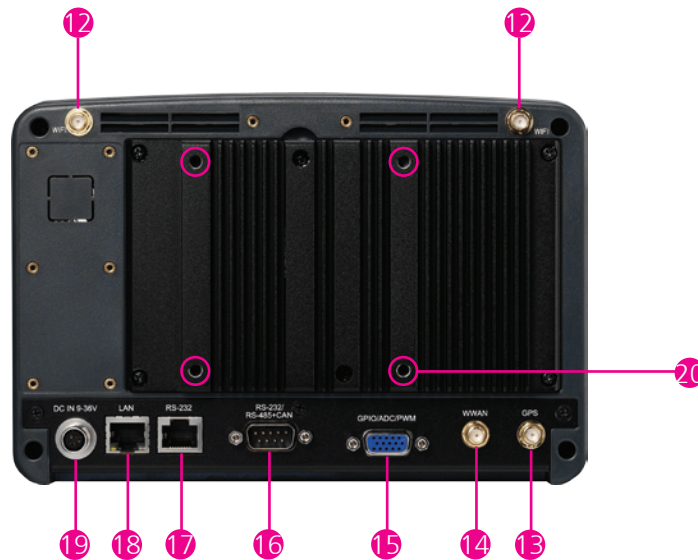

Note: The photo shown is VMC 1100

Item	Function	Description
1	Function Key	There are five buttons and 5 function keys on the VMC 100/1100 series.
2	Speaker	VMC 100/1100 includes the dual speaker; the specification is 2W/ 8Ω.
3	Internal Mic-in	Built-in microphone, does not need any monophonic input from an external microphone.
4	Light Sensor	Light sensors can adjust a display's backlight, which improves the power savings and optimizes the display's viewability.
5	Indicator	<ul style="list-style-type: none"> Power mode No power, no light Initial power-on: Green indicator stays lit around 2~3 seconds. Boot loader or BIOS status: Orange indicator blinking for 1 second. System login in status: Green indicator blinking for 1 second. All process ready in system, ready for customer use: Green indicator stays lit. Storage: Green, data is being read from or written to the storage driver. WWAN: Green, the wireless WAN is on, and the radio link is ready for use. Blinking green, data is being transmitted.
6	Power Key	<ul style="list-style-type: none"> When the ignition is from "low" to "high", VMC will turn on automatically. When the ignition is "high", press the power button 5 seconds to turn on/off VMC. When the ignition is from "high" to "low", VMC will turn off automatically. When the ignition is "low", pressing the power button will not turn on VMC. When you press it for 1 second, the display will turn on/off.
7, 8	Volume key/ Brightness Control key	Volume Up/ Down (Default): Audio volume can be adjusted in 10 levels using the buttons. Brightness Control: There are two modes for Brightness Control: Manual Mode and Auto Mode. In Manual Mode, LCD brightness can be adjusted in 10 levels using the "+" or "-" buttons.
9	Reset	Hardware reset.
10	Left Side I/O with Special Screw Lock	VMC 100 <ul style="list-style-type: none"> SIM card slot USB client, type B connector VMC 1100 <ul style="list-style-type: none"> SIM card slot Micro SD slot

Item	Function	Description																																		
11	Left Side I/O	VMC 100 <ul style="list-style-type: none"> • USB 2.0 • Mic-in • Line-out VMC 1100 <ul style="list-style-type: none"> • USB 3.0 • Mic-in • Line-out 																																		
12	Wi-Fi Antenna Connector	<ul style="list-style-type: none"> • The 2 external SMA type antenna mounting connectors are used to connect the antenna to a WLAN module and Bluetooth. 																																		
13	GPS Antenna Connector	<ul style="list-style-type: none"> • The external SMA type antenna mounting connector is used to connect the antenna to a GPS module. 																																		
14	WWAN Antenna Connector	<ul style="list-style-type: none"> • The external SMA type antenna mounting connector is used to connect the antenna to a WWAN module. 																																		
15	Multi I/O Port	DB15 female connector with GPIO/ADC/PWM. <table border="1" style="display: inline-table; margin-right: 20px;"> <thead> <tr> <th>Pin</th> <th>Description</th> </tr> </thead> <tbody> <tr><td>1</td><td>Speed 1</td></tr> <tr><td>2</td><td>Speed 2</td></tr> <tr><td>3</td><td>ADC 0</td></tr> <tr><td>4</td><td>ADC 1</td></tr> <tr><td>5</td><td>A_GND</td></tr> <tr><td>6</td><td>GPI 1</td></tr> <tr><td>7</td><td>GPI 2</td></tr> <tr><td>8</td><td>VMC 100: GPI3 VMC 1100: MDI 1 (for tracker, SOS)</td></tr> </tbody> </table> <table border="1" style="display: inline-table;"> <thead> <tr> <th>Pin</th> <th>Description</th> </tr> </thead> <tbody> <tr><td>9</td><td>GPO 1</td></tr> <tr><td>10</td><td>GPO 2</td></tr> <tr><td>11</td><td>VMC 100: GPO 3 VMC 1100: MDI 2 (for tracker, release KEY)</td></tr> <tr><td>12</td><td>DR GPS_IPPS</td></tr> <tr><td>13</td><td>DR GPS_ODO</td></tr> <tr><td>14</td><td>DR GPS_DIR</td></tr> <tr><td>15</td><td>GND</td></tr> </tbody> </table>	Pin	Description	1	Speed 1	2	Speed 2	3	ADC 0	4	ADC 1	5	A_GND	6	GPI 1	7	GPI 2	8	VMC 100: GPI3 VMC 1100: MDI 1 (for tracker, SOS)	Pin	Description	9	GPO 1	10	GPO 2	11	VMC 100: GPO 3 VMC 1100: MDI 2 (for tracker, release KEY)	12	DR GPS_IPPS	13	DR GPS_ODO	14	DR GPS_DIR	15	GND
Pin	Description																																			
1	Speed 1																																			
2	Speed 2																																			
3	ADC 0																																			
4	ADC 1																																			
5	A_GND																																			
6	GPI 1																																			
7	GPI 2																																			
8	VMC 100: GPI3 VMC 1100: MDI 1 (for tracker, SOS)																																			
Pin	Description																																			
9	GPO 1																																			
10	GPO 2																																			
11	VMC 100: GPO 3 VMC 1100: MDI 2 (for tracker, release KEY)																																			
12	DR GPS_IPPS																																			
13	DR GPS_ODO																																			
14	DR GPS_DIR																																			
15	GND																																			

Item	Function	Description		
16	Multi I/O Port	DB9 male connector with RS-232 or RS-485 and CAN bus.		
			Pin	Description
			1	GND
			2	RX/ RS-485+
			3	RS-485-
			4	TX
			5	GND
			6	CAN1 H
			7	CAN1 L
			8	CAN2 H
9	CAN2 L			
17	COM1	RJ-45 connector with RS-232 interface of either 0, 5 or 12V on pin 9 for external devices.		
			Pin	Description
			1	0/ 5/ 12V
			2	RX
			3	TX
			4	DTR
			5	GND
			6	DSR
			7	RTS
8	CTS			
18	LAN Port	The LAN port is an RJ45 interface with integrated LEDs and supports 10/100/1000Mbps Ethernet data transfer rates.		

Item	Function	Description		
19	Power Input Connector	9 ~ 36VDC power input		
			Pin	Description
			1	GND (Black line color)
			2	GND (Black line color)
			3	IGNITION (Yellow line color)
			4	VIN (Red line color)
		5	VIN (Red line color)	

CHAPTER 2: USING THE GPS FEATURE

The VMC has a built-in GPS receiver module by default. Global Positioning System (GPS) uses a constellation of 24 (up to 32) medium earth orbit satellites to transmit and receive microwave signals to determine its current location.

You need to install the third-party GPS navigation software to take advantage of the GPS feature.

Setup and Using GPS Information

Users can use the Gpsinfo.exe program to verify that the GPS is correctly configured and working properly. Also, users can use the Gpsinfo.exe program to enable WAAS/EGNOS and power saving mode.

1. Go to Device Manager to ensure the device is installed correctly.

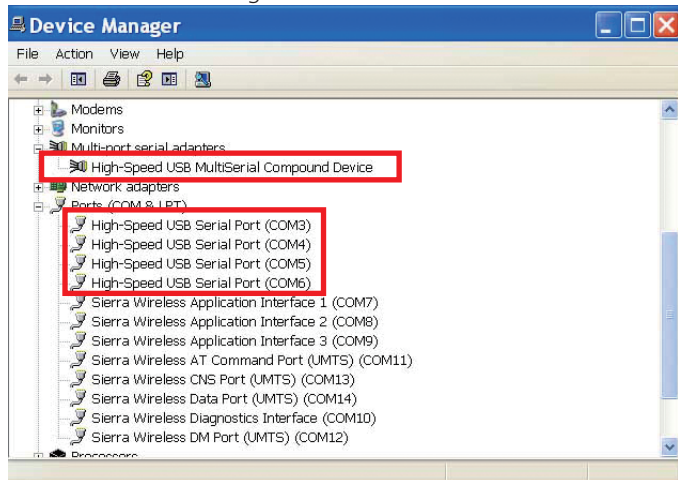

2. Insert the Installation Disc into CD-Rom drive and execute the “Gpsinfo.exe” file (the file also saved in C:\Utility\GPS_Utility).

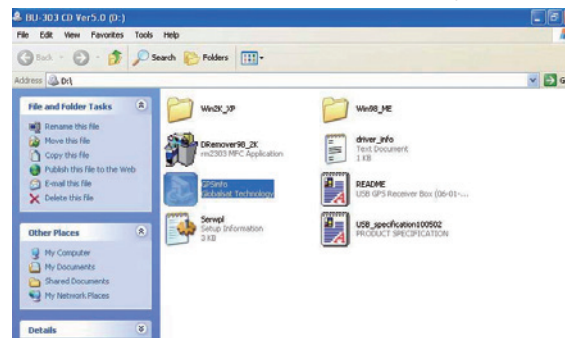

3. Follow the given instructions to complete the installation.

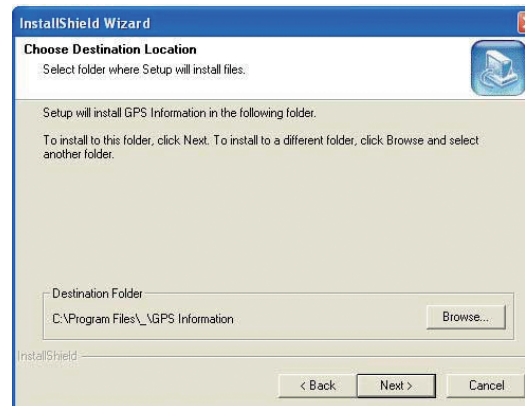

4. When the setup complete, press <Finish>.

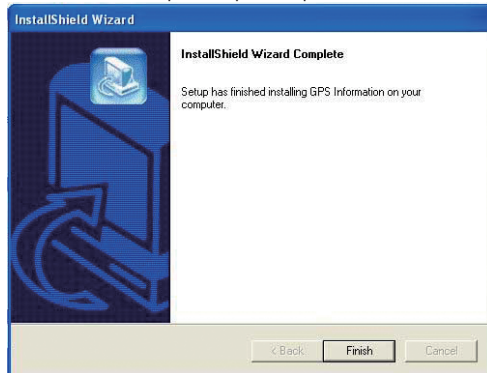

5. Once the installation is completed, installation of GPS Information onto PDA device will be launched automatically. Select <Yes> to continue.

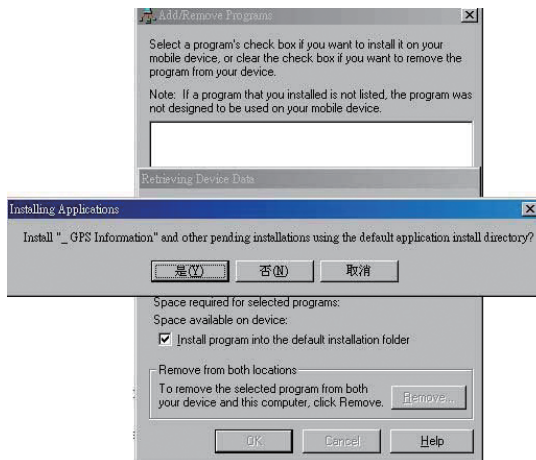

Setup Window Screenshot

Double click GpsInfo_Vista icon from Desktop to start GPS.

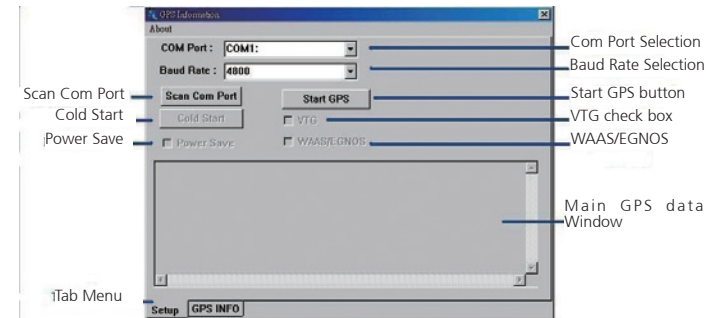

- Scan Com Port” - Scan all available communication port for GPS reception
- “Cold Start” - Cold start the GPS receiver
- “Power Save” - Check the box to enable/disable the Power Save Mode (the option is available only when a GPS device is found)
- “Tab Menu” - Switch between Setup and GPSINFO windows
- “Com Port Selection” - Select the appropriate communication port where GPS receiver is configured (it may be necessary to try several communication ports until the right one is found)
- “Baud Rate Selection” - Select the appropriate transferring rate (**Please set the baud rate at 38400**)
- “Start GPS button” - Turn on/off the GPS device
- “VTG check box” - Some navigation or map software requires to receive VTG data output for during operation. Check the box to activate the VTG data output.

- “WAAS/EGNOS” - Check the box to activate WAAS/EGNOS in order to increase the accuracy of positioning
- “Main GPS data Window” - Display data received by GPS device.

GPS Info Window Screenshot

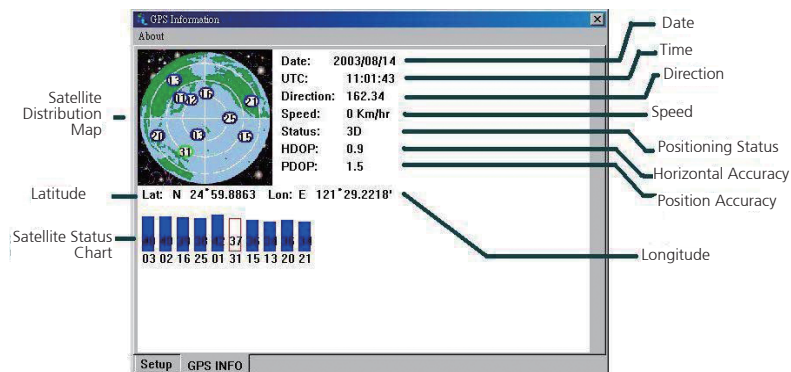

- “Satellite Distribution Map” – Display the position of all connected Satellites
 - A unique number is assigned to each satellite.
 - Red circle indicates that the satellite location is known from almanac information; however, the satellite is not currently being tracked.
 - Green circle indicates that the satellite is being tracked; however, it is not being used in the current position solution.
 - Blue circle indicates that it is being tracked and is being used in the current position.

- “Latitude” – User’s current latitude is displayed in N/S degree (North/South Hemisphere) format
- “Satellite Status Chart” – display the status of each connected satellite
 - The number under each bar marks corresponding Satellite, and the height of each bar represents the strength of the satellite.
 - Red bar indicates that the satellite location is known from almanac information; however, the satellite is not currently being tracked.
 - Green solid bar indicates that the satellite is being tracked; however, it is not being used in the current position solution.
 - Blue bar indicates that the tracked and is being used in the current position.
- “Date” – display the current date in (dd/mm/yy) format.
- “Time” – display the current (UTC) time in (hh:mm:ss) format.
- “Direction” – display the current direction from 000.0° to 359.9°
- “Speed” – Display the current moving speed in km/hour
- “Positioning Status”- Three Modes
 1. No Fix
 2. 2D Positioning
 3. 3D Positioning
- “Horizontal Accuracy” - Range from 0.5 to 99.9, the smaller the better
- “Position Accuracy” - Range from 0.5 to 99.9, the smaller the better
- “Longitude” – Display current longitude in E/W (East/West Hemisphere) Time (hhmmss)

GPS Information Instructions

1. Make sure that the GPS device is properly inserted.
2. Start GPS Information Software.
3. Choose and select the proper communication port. (It might be necessary to try each available port to find the right one since the default communication port varies according to different hardware device.)
4. Click "Start GPS button" to activate the GPS receiver.
5. Upon successful connection, GPS output data should be displayed in "Main GPS data Window". If no data is observed, make sure the GPS receiver is working and properly inserted. Otherwise choose another communication port.
6. Satellite status can be observed in the "GPS Info Window". Use the "Tab Menu" to switch between Setup window and GPS info window.
7. Please make sure to de-activate the GPS device before exiting this program.

CHAPTER 3: JUMPERS AND CONNECTORS

This chapter describes how to set the jumpers on the motherboard. Note that the following procedures are generic for all VMC 100/1100 series.

Before You Begin

- Ensure you have a stable, clean working environment. Dust and dirt can get into components and cause a malfunction. Use containers to keep small components separated.
- Adequate lighting and proper tools can prevent you from accidentally damaging the internal components. Most of the procedures that follow require only a few simple tools, including the following:
 - A Philips screwdriver
 - A flat-tipped screwdriver
 - A set of jewelers Screwdrivers
 - A grounding strap
 - An anti-static pad
- Using your fingers can disconnect most of the connections. It is recommended that you do not use needle-nosed pliers to disconnect connections as these can damage the soft metal or plastic parts of the connectors.
- Before working on internal components, make sure that the power is off. Ground yourself before touching any internal components, by touching a metal object. Static electricity can damage many of the electronic com-

ponents. Humid environment tend to have less static electricity than dry environments. A grounding strap is warranted whenever danger of static electricity exists.

Precautions

Computer components and electronic circuit boards can be damaged by discharges of static electricity. Working on the computers that are still connected to a power supply can be extremely dangerous.

Follow the guidelines below to avoid damage to your computer or yourself:

- Always disconnect the unit from the power outlet whenever you are working inside the case.
- If possible, wear a grounded wrist strap when you are working inside the computer case. Alternatively, discharge any static electricity by touching the bare metal chassis of the unit case, or the bare metal body of any other grounded appliance.
- Hold electronic circuit boards by the edges only. Do not touch the components on the board unless it is necessary to do so. Don't flex or stress the circuit board.
- Leave all components inside the static-proof packaging that they shipped with until they are ready for installation.
- Use correct screws and do not over tighten screws.

Jumper

A jumper is the simplest kind of electric switch. It consists of two metal pins and a cap. When setting the jumpers, ensure that the jumper caps are placed on the correct pins. When the jumper cap is placed on both pins, the jumper is **short**. If you remove the jumper cap, or place the jumper cap on just one pin, the jumper is **open**.

Refer to the illustrations below for examples of what the 2-pin and 3-pin jumpers look like when they are short (on) and open (off).

Two-Pin Jumpers: Open (Left) and Short (Right)

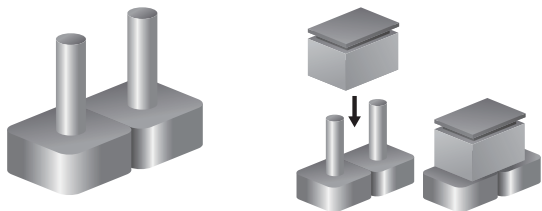

Three-Pin Jumpers: Pins 1 and 2 Are Short

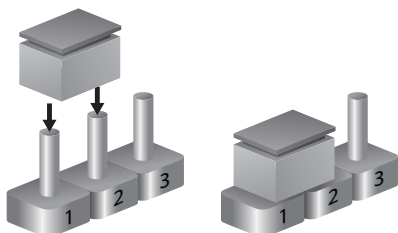

Locations of the Jumpers and Connectors

The figure below is the mainboard used in the VMC system. It shows the locations of the jumpers and connectors.

Mainboard

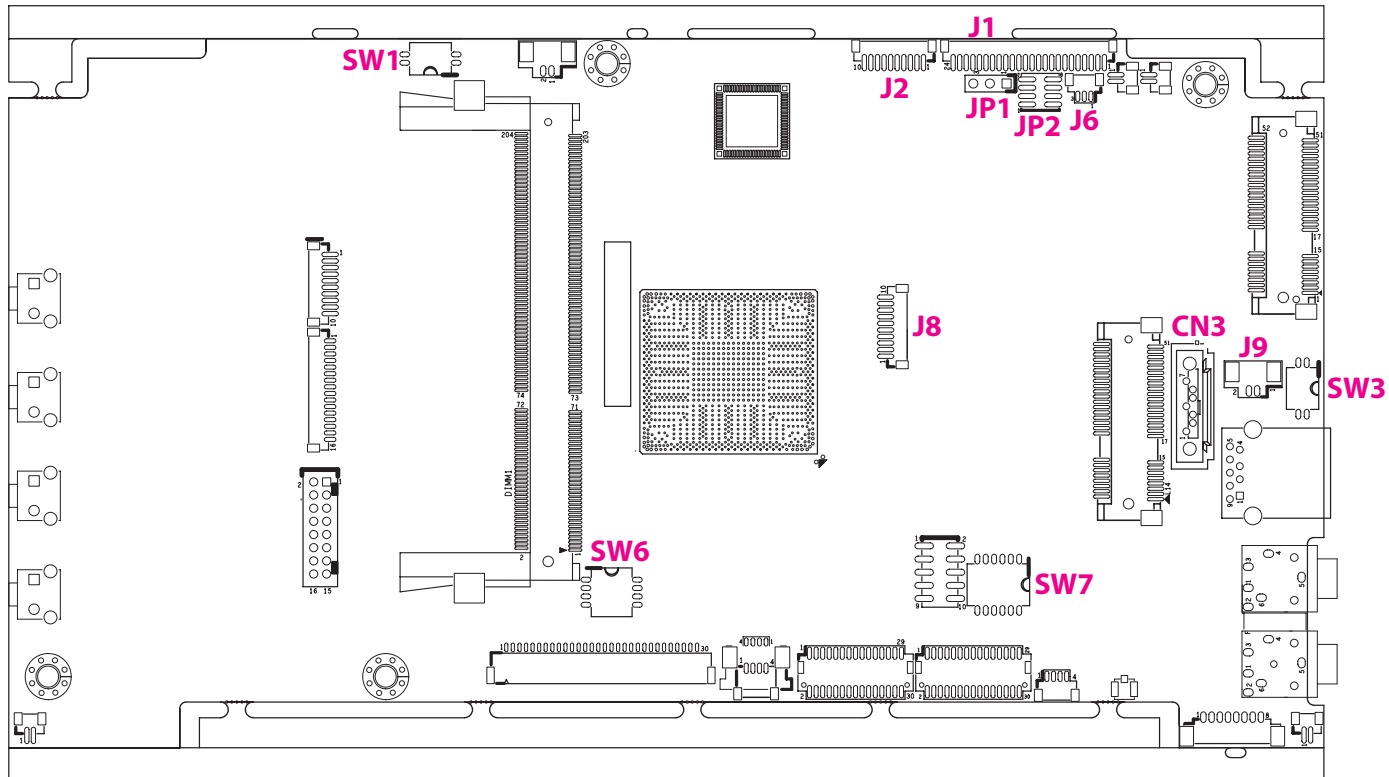

Internal Connectors and DIP Switch Settings

VGA Connector

Connector size: 1x10 10-pin header, 1.0mm pitch
Connector location: J2



Pin	Definition	Pin	Definition
1	VGA_+5V	2	VGA_CLK
3	VGA_DATA	4	VGA_VS
5	VGA_HS	6	GND
7	VGA_BLUE	8	VGA_GREEN
9	VGA_RED	10	GND

Flash/Debug Connector

Connector size: 1x24 24-pin wafer, 1.0mm pitch
Connector location: J1



Pin	Definition	Pin	Definition
1	GND	2	GND
3	EC_KSI5	4	EC_KSI4
5	EC_KSI3	6	EC_KSI2
7	EC_KSI1	8	EC_KSI0
9	GND	10	GND
11	GND	12	GND
13	GND	14	EC_KSO10
15	EC_KSO9	16	EC_KSO8
17	EC_KSO7	18	EC_KSO6
19	EC_KSO5	20	EC_KSO4
21	EC_KSO3	22	EC_KSO2
23	EC_KSO1	24	EC_KSO0

MCU Debug COM Header

Connector size: 1x3 3-pin header, 1.0mm pitch

Connector location: JP1



Pin	Definition
1	TX
2	RX
3	GND

MCU Flash Connector

Connector size: 2x4 8-pin header, 1.0mm pitch

Connector location: JP2

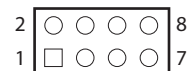

Pin	Definition	Pin	Definition
1	+V3.3ALW	2	MCU_RST#
3	MCU_TRST	4	MCU_TDI
5	MCU_TCK	6	MCU_TMS
7	MCU_TDO	8	GND

EC Debug COM Connector

Connector size: 1x3 3-pin header, 1.0mm pitch

Connector location: J6

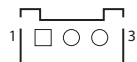

Pin	Definition
1	RX
2	GND
3	TX

Port 80 Debug Connector

Connector size: 1x10 10-pin header, 1.0mm pitch

Connector location: J8



Pin	Definition	Pin	Definition
1	GND	2	PCIRST#
3	33M_CLK	4	LPC_FRAME#
5	LPC_AD3	6	LPC_AD2
7	LPC_AD1	8	LPC_AD0
9	VCC3	10	VCC3

Serial-ATA

Connector size: Standard Serial ATA 7P (1.27mm, SATA-M-180)

Connector location: CN3

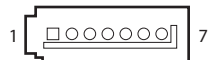

Pin	Definition	Pin	Definition
1	GND	2	SATA0_TXP
3	SATA0_TXN	4	GND
5	SATA0_RXN	6	SATA0_RXP
7	GND		

SATA DOM Power Connector

Connector size: 1x2 2-pin header, 1.25mm pitch

Connector location: J9



Pin	Definition
1	GND
2	VCC5

ME/RTC Clear Switch

Connector size: 2-pin DIP switch

Connector location: SW1

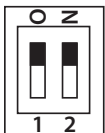

Pin	Status	Function
1-2	ON	Clear CMOS/ME
1-2	OFF	Normal

Input Voltage Control Switch

Connector size: 2-pin DIP switch

Connector location: SW3

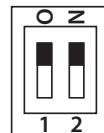

Pin	Status	Function
1-2	OFF	12V
1-2	1 OFF, 2 ON	24V
1-2	On	9-36V

GPIO Pull High Switch

Connector size: 6-pin DIP switch

Connector location: SW7

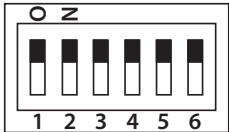

Pin	Status	Function
1-6	ON	GPIO Output Pull High
1-6	OFF	GPIO Output NC

LED Indicators



LED	Description
Power	Initial power-on: Green LED for 2~3 seconds Boot loader or BIOS status: Blinking orange System login in status: Blinking green Power On: Solid green
HDD	HDD activity: Green
WWAN	WWAN activity: Green

External Connectors

RS232 Connector

Connector size: RJ45 port
 Connector location: CON1

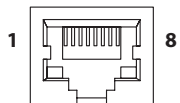

Pin	Definition	Pin	Definition
1	COM1-PWR	2	RS232_RXD
3	RS232_TXD	4	RS232_DTR
5	GND	6	RS232_DSR
7	RS232_RTS	8	RS232_CTS

RS485/CAN Connector

Connector size: DB-9 port, 9-pin D-Sub
 Connector location: CN1

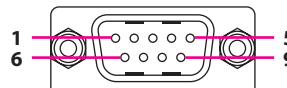

Pin	Definition	Pin	Definition
1	COM-PWR	2	COM_RX_485TX+
3	RS-485TX-	4	COM_TX
5	GND	6	CAN1-H
7	CAN1-L	8	CAN2-H
9	CAN2-L		

GPIO and Sensor Connector

Connector size: DB-15 port, 15-pin D-Sub

Connector location: CN3

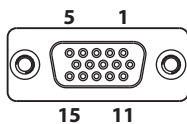

Pin	Definition	Pin	Definition
1	SPEED_1	2	SPEED_2
3	A-VIN0	4	A-VIN1
5	IO_AGND	6	G_IN-1
7	G_IN-2	8	G_IN-8
9	G_OUT-1	10	G_OUT-2
11	G_OUT-3	12	DR_GPS-1PPS
13	DR_GPS-ODOMETER	14	DR_GPS-DIRECTION
15	IO_GND1		

CHAPTER 4: FUNCTION KEY CODE CONSTANTS

Visual Basic Reference

Constant	Value	Description
vbKeyF1	112	F1 key
vbKeyF2	113	F2 key
vbKeyF3	114	F3 key
vbKeyF4	115	F4 key
vbKeyF5	116	F5 key

Note: Source by Microsoft website

[http://msdn.microsoft.com/en-us/library/aa243025\(v=VS.60\).aspx](http://msdn.microsoft.com/en-us/library/aa243025(v=VS.60).aspx)

“How to capture a pressed function keys”, please refer to the Microsoft technical support website

<http://support.microsoft.com/kb/822492/en-us>

Key code value for ActionScript 2.0 in Adobe Flash

http://help.adobe.com/en_US/AS2LCR/Flash_10.0/help.html?content=00000520.html

Extended ASCII Keyboard Codes

Char.	Meaning Hex	Octal	Binary
F1 key	59	3B	073 00111011
F2 key	60	3C	074 00111100
F3 key	61	3D	075 00111101
F4 key	62	3E	076 00111110
F5 key	63	3F	077 00111111

CHAPTER 5: TOUCHSCREEN INSTALLATION GUIDE

This chapter applies to VMC 1100 and describes how to install drivers and other software that enables your touchscreen controller to work with various operating systems.

The touchscreen supports the following operating systems:

O.S.	DOS	2000/XP/2003/VISTA/7/8	Linux (Kernel 2.6 & X-Windows Mode)	Win CE (4.2/5.0/6.0/7.0)
Driver				
USB Driver		✓	✓	✓

5.1 Install PenMount Windows Universal Driver (for 2000/XP/XPT/XPE/2003/VISTA/7/WES7/2008/8)

Before installing **PenMount Windows Universal Driver**, you must have had installed one of the operating systems from Windows 2000/XP/XPT/XPE/2003/VISTA/7/WES7/2008/8 in your computer, and one of PenMount control boards from 6200x, 6202B, 6300x, or 6500x must have been installed.

Before installing PenMount Windows Universal driver V2.4.0.306, you may modify the default options from \PenMount Universal Driver V2.4.0.306\Driver\Install.ini:

Install	USB	1. Install PenMount USB driver. 0. Uninstall PenMount USB driver.
	COM	1. Install PenMount RS232 driver. 0. Uninstall PenMount RS232 driver.
	MMonitor	1. Install PenMount driver for multi-device recognition. 0. Uninstall PenMount driver for multi-device recognition.
	ENUM	1. Install PenMount driver for non-pnp device recognition. 0. Uninstall PenMount driver for non-pnp device recognition.
Option	TouchReport	1. The default setting of Windows 2k/XP/Vista/7 is mouse mode. 2. The default setting of Windows 2k/XP is mouse mode; the default setting of Windows 7/ Vista is digitizer mode.
	EdgeOffset	0, 5, 10, 15, 20, 25, 30 are the default values for edge compensation.
	Smoothing	1. Turn on the smoothing function. 0. Turn off the smoothing function.

	Operation	The default settings of operating mode: 0. Pen Input Emulation 2. Mouse Emulation 1. Click on Touch 3. Click on Release
	CalibOffset	This function is unable to be modified.
	RBtnPressNHold	0. Turn on long-pressed right key function. 1. Turn off long-pressed right key function.
Serial	ScanAllPorts	1. Turn on "Scan All Ports" to confirm PenMount RS232 device. 0. Turn off "Scan All Ports" for the confirmation of PenMount RS232 device.
	COM3=xxxx,yyyy	To set up the permanent system COM port for PenMount RS232 driver. COM3-to correct it to be correspondent with the actual COM PORT. xxxx-the supporting item number: 9000/ 6000 or PCI. yyyy-the baud rate 19200 or 9600 of item 6000 or item 9000; baud rate 38400 is only for PCI items. # Please note that the information above must be correct, so that the device can just work normally, and ENUM must be set as 1. Example: COM1= PCI, 38400 # Permanently install PCI RS232 38400bps at COM1 COM3= 6000,19200 #Permanently install PM6000 RS-232 19200bps at COM3 COM4=9000,9600 #Permanently install PM9000 RS-232 9600bps at COM4
<p>PS. Set the symbol";" in front of the parameter, which means not to perform the parameter. Example: ; TouchReport =2, it will not be installed as Digitizer mode directly in Windows 7, the user can select Digitizer or mouse mode during the installation procedure. ; COM1=PCI,38400, it will not install the driver at COM1 permanently.</p>		

5.1.1 Install PenMount Mouse Driver in Windows 2000/XP/XPT/XPE/2003/VISTA/7/WES7/2008/8

If you have an older PenMount driver installed on your system, uninstall it first and follow the steps below to install **PenMount Windows Universal Driver**:

Plug in your PenMount 6000 control board and install **PenMount Windows Universal Driver**. Make sure the driver is installed before control board is plugged. Then the driver will have the assigned COM port or USB port detect PenMount device.

To install the driver:

1. In folder **PenMount Universal Driver**, find "**Setup.exe**" and run it.
2. A **License Agreement** window appears. Click "**I Agree**" and "**Next**".
3. When ready to install the program, click "**Install**".
4. Installation takes some time.
5. When the warning message screen appears, please click "**Continue Anyway**" to continue.



6. When the window below shows up, please select "yes" for installing PenMount as mouse mode; select "no" for digitizer mode. If your operating system doesn't support Windows tablet input, digitizer device can't be used, therefore you have to select "yes" here, otherwise after the installation the touch doesn't work after re-booting.

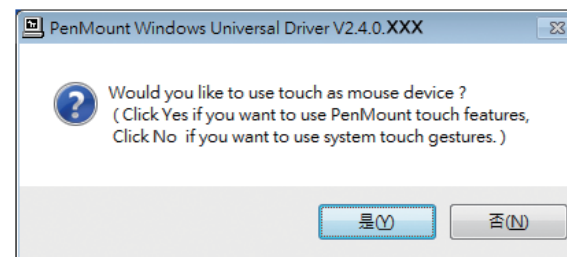

7. A window notifying of installation completion appears. Click "**Finish**".

NOTE: If you are installing the driver with Microsoft WHQL, you will see the screen in step 6 directly instead of step 5.

8. Then restart operating system.

As soon as driver installation finishes, both the icons of **PenMount Monitor** and **Gesture AP** show up in the notification area.



5.1.2 Install PenMount Digitizer Driver in Windows XPT/VISTA/7/WES7/2008/8

The installation steps of the default settings are consistent with XP. When you select “no” for step 6, PenMount will be installed as a digitizer device; If your operating system doesn’t support Windows tablet input, digitizer device can’t be used, therefore you have to select “yes” here, otherwise after the installation the touch doesn’t work after re-booting.

After the installation, you will see the difference that a **PenMount Control Panel** icon shows up on the desktop without a icon in the notification area. See the screenshot below:

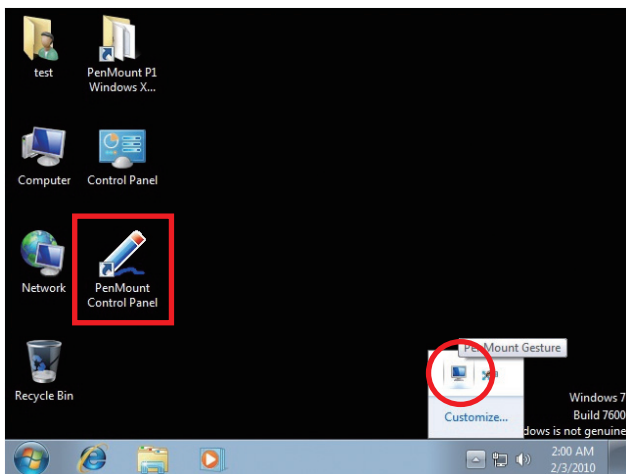

5.1.3 Configure Touchscreen In PenMount mouse driver

Click on the **PenMount Monitor** icon in the notification area and select **Control Panel** from the menu.

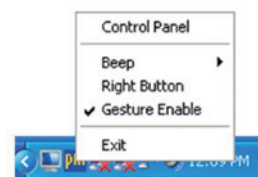

On **PenMount Control Panel** you are able to see the device of PenMount 6000 USB/RS-232 detected by your system under **Device** tab. Select a device and click the **Configure** button.

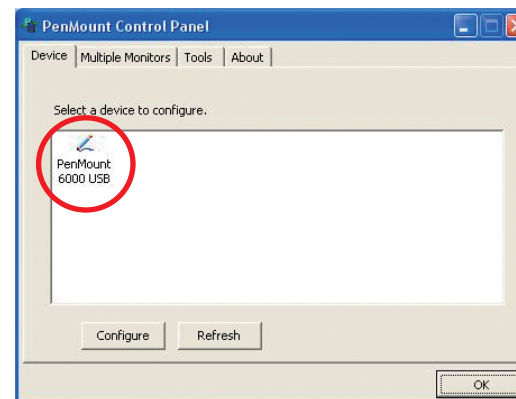

5.1.4 PenMount Control Panel

The functions under **PenMount Control Panel** are:

Device

In this window, you can find out how many devices are detected by your system.

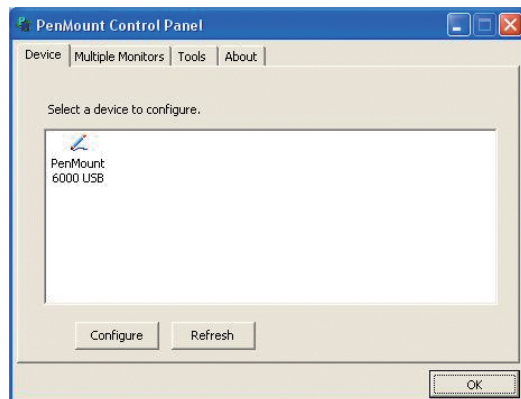

Calibrate

This function offers two ways to calibrate your touchscreen. '**Standard Calibration**' adjusts most touchscreens while '**Advanced Calibration**' adjusts aging touchscreens.

Standard Calibration

Click this button and arrows appear pointing to red squares. Use your finger or stylus to touch the red squares in sequence. After the fifth red point calibration is complete. To skip, press '**ESC**'.

Advanced Calibration

Advanced Calibration uses 9, 16 or 25 points to effectively calibrate touch panel linearity of aged touchscreens. Click this button and touch the red squares in sequence with a stylus. To skip, press '**ESC**'.

Command Calibration

Command call calibration function. Use command mode call calibration function, this can uses 4, 9, 16 or 25 points to calibrate.

E.g. Please run ms-dos prompt or command prompt.
 c:\Program Files\PenMount Universal Driver\DMCCtrl.exe
 -calibration 4 (Standard Calibration)

DMCCtrl.exe - calibration (\$)
 4=Standard Calibration 4
 9=Advanced Calibration 9
 16=Advanced Calibration 16
 25=Advanced Calibration 25

To calibrate your touchscreen:

1. Please select a device then click **“Configure”**. You can also double click the device too.

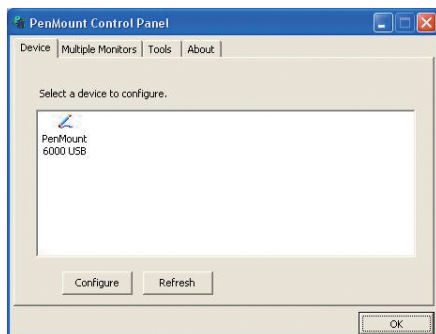

2. Click **“Standard Calibration”** to start standard calibration or **“Advanced Calibration”** to start Advanced Calibration.

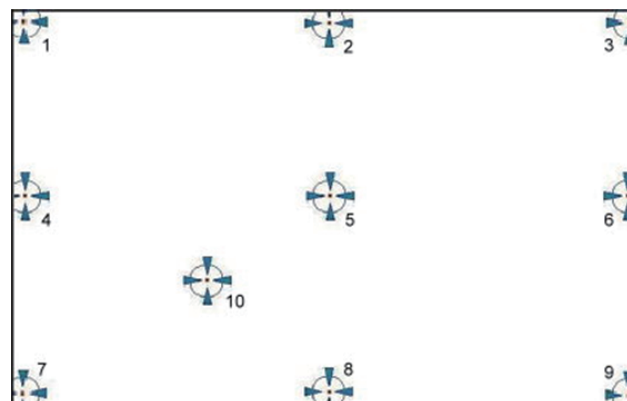
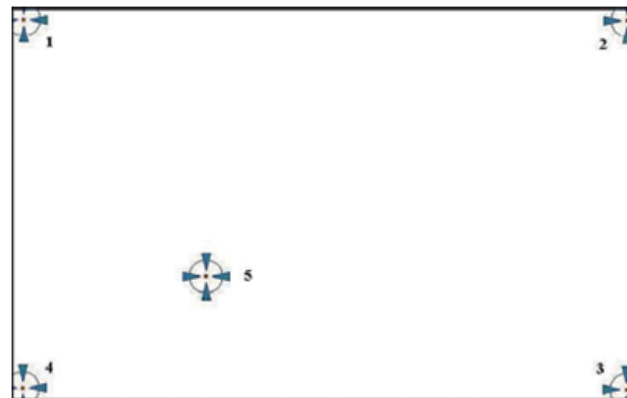
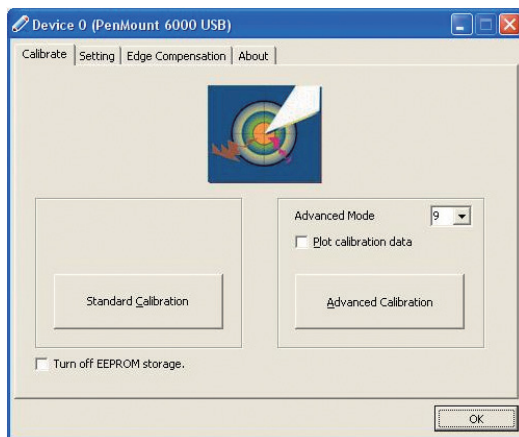

NOTE: The older a touchscreen is, the more calibration points of the **Advanced Mode** it needs. For an optimal accuracy we suggest to use a stylus to make the advanced calibration.

Plot Calibration Data

Check this function to have touch panel linearity comparison graph appear when you finish **Advanced Calibration**. The black lines reflect the ideal linearity assumed by PenMount's application program while the blue lines show the approximate linearity calculated by PenMount's application program as the result of user's execution of **Advance Calibration**.

Turn off EEPROM storage

This function disables the write-in of calibration data in **Controller**. This function is enabled by default.

Setting

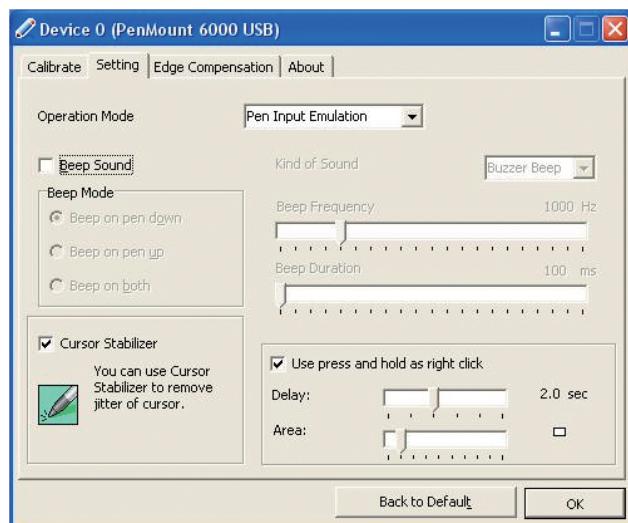

Operation Mode

This mode enables and disables mouse's ability of dragging on-screen icons—useful for configuring POS terminals.

Pen Input Emulation

Select this mode and mouse will emulate Windows Vista pen input device operation, by which no mouse event will be sent until the touch is dragged out of range or released from the screen.

Mouse Emulation

Select this mode and mouse functions as normal and allows dragging of icons.

Click on Touch

Select this mode and mouse only provides a click function, and dragging is disabled.

Click on Release

Select this mode and mouse only provides a click function when the touch is released.

Beep Sound

Enable Beep Sound

turns beep function on and off.

Beep on Pen Down

beep occurs when pen comes down.

Beep on Pen Up

beep occurs when pen is lifted up.

Beep on both

beep occurs when comes down and is lifted up.

Beep Frequency

modifies sound frequency.

Beep Duration

modifies sound duration.

Cursor Stabilizer

Enable the function support to prevent cursor shake.

Use press and hold as right click

You can set the time out and area for you need

Edge Compensation

This page is the edge compensation settings. You can adjust the settings from 0 to 30 for accommodating the difference of each touch panel.

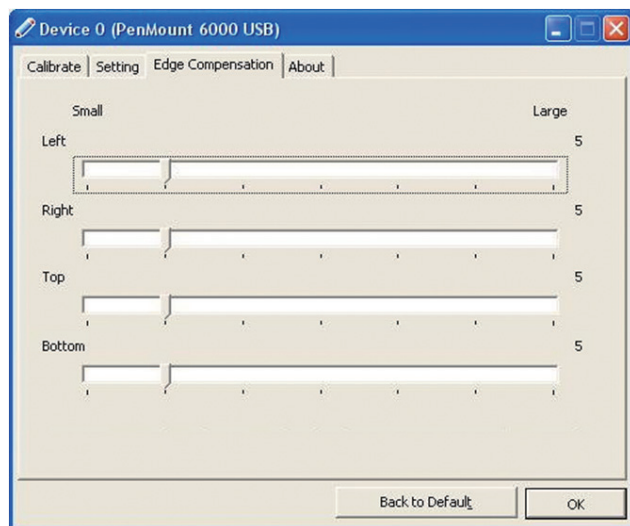

About

This panel displays information about the PenMount controller and driver version.

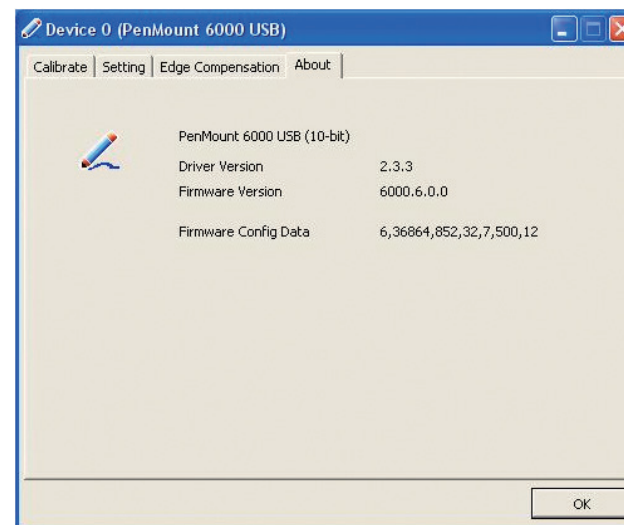

5.1.5 PenMount Monitor Menu Icon

PenMount Monitor icon (PM) appears in the notification area of Windows system when you turn on **PenMount Monitor** in **PenMount** utility.



PenMount Monitor has the following functions:

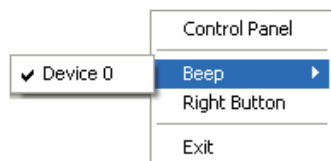

- Control Panel** Open PenMount **Control Panel**.
- Beep** Setting **Beep** function for each device.
- Right Button** When you select this function, a mouse icon appears in the right-bottom of the screen. Click this icon to switch between **Right** and **Left Button** functions.
- Exit** Exits the **PenMount Monitor** function.

5.1.6 PenMount Rotating Function

PenMount Windows Universal Driver supports several display rotating software packages and auto-detects rotate function (0°, 90°, 180°, 270°). The display rotating software package supported in Windows 2000, XP 32bit, Vista 32/64bit are:

1. Intel Display Driver Rotate Function.
2. ATI Display Driver Rotate Function.
3. nVidia Display Driver Rotate Function.
4. SMI Display Driver Rotate Function.
5. Portrait's Pivot Screen Rotation Software.

Configure Rotate Function in Windows XP 64bit

1. There is a "**Screen Rotation Monitor**" button that appears only in the PenMount driver utilities for Windows XP 64bit system.

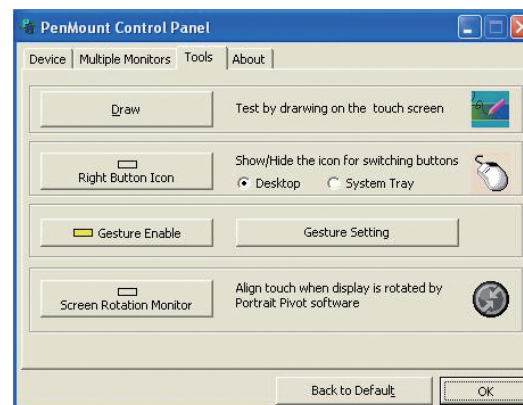

- On enabling “**Screen Rotation Monitor**”, you will see a screen like below:



- Choose rotate function (0°, 90°, 180°, 270°) in the 3rd party software. The calibration screen will appear automatically. Touch this point and rotation is mapped.

NOTE: Rotate function is disabled if you use **Monitor Mapping**.

5.1.7 The Touchscreen Configure of PenMount Digitizer Driver

With PenMount Windows Universal V2.2.0.283 and the later versions, since the touchscreen is automatically installed as a digitizer device in Windows Vista/7, the functions built in Windows Vista / 7 such as rotation, multi-monitor, flicks, and context menu function (which launches a context menu by user’s long-pressing on touchscreen rather than clicking the right mouse button or pressing the application key on the keyboard) will be supported.

To configure touchscreen in PenMount Digitizer driver:

Double-click on the **PenMount Control Panel** icon on the Desktop.



On **PenMount Control Panel** you are able to see the device of PenMount 6000 USB/RS-232 detected by your system under **Device** tab. Select a device and click the **Configure** button.

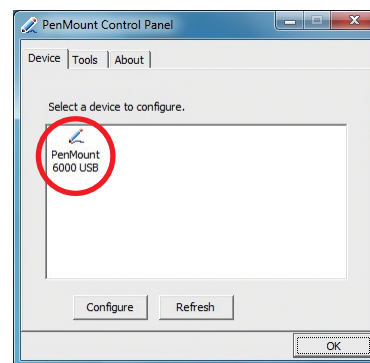

5.1.7.1 PenMount Control Panel

The functions under **PenMount Control Panel** are:

Device

In this window, you can find out how many devices are detected on your system.

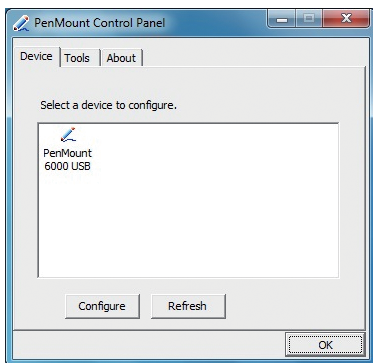

Calibrate

This function offers two ways to calibrate your touchscreen. '**Standard Calibration**' adjusts most touchscreens while '**Advanced Calibration**' adjusts aging touchscreens.

Standard Calibration

Click this button and arrows appear pointing to red squares. Use your finger or stylus to touch the red squares in sequence. After the fifth red point calibration is complete. To skip, press '**ESC**'.

Advanced Calibration

Advanced Calibration uses 9, 16 or 25 points to effectively calibrate touch panel linearity of aged touchscreens. Click this button and touch the red squares in sequence with a stylus. To skip, press '**ESC**'.

Command Calibration

Command call calibration function. Use command mode call calibration function, this can uses 4, 9, 16 or 25 points to calibrate.

E.g. Please run ms-dos prompt or command prompt.
c:\Program Files\PenMount Universal Driver\DMCCtrl.exe -calibration 4 (Standard Calibration)

DMCCtrl.exe - calibration (\$)
4= Standard Calibration 4
9= Advanced Calibration 9
16= Advanced Calibration 16
25= Advanced Calibration 25

To calibrate your touchscreen:

1. Please select a device then click **“Configure”**. You can also double click the device too.

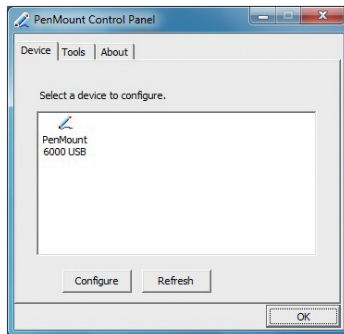

2. Click **“Standard Calibration”** to start standard calibration or **“Advanced Calibration”** to start Advanced Calibration.

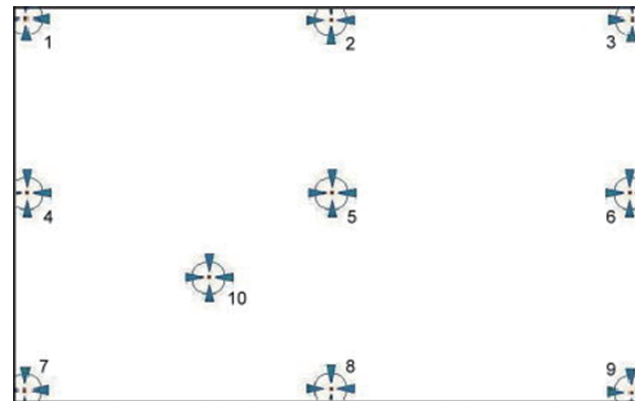
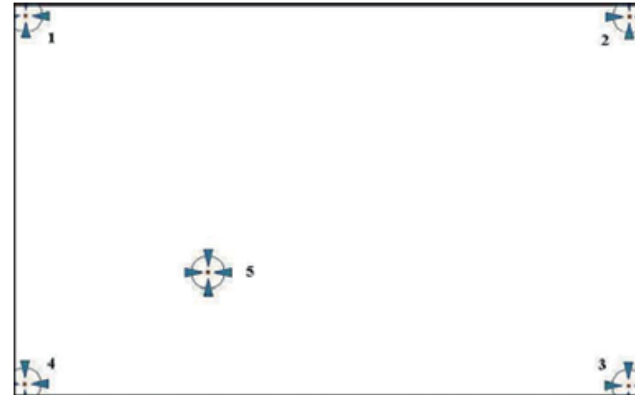
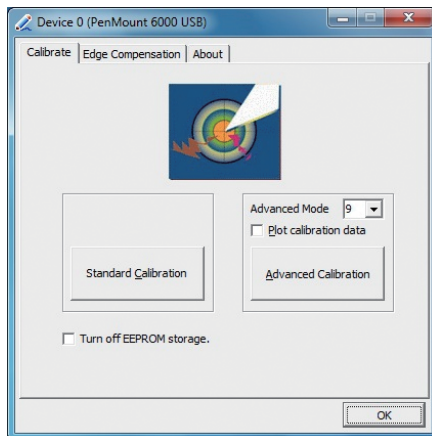

NOTE: The older a touchscreen is, the more calibration points of the **Advanced Mode** it needs. For an optimal accuracy we suggest to use a stylus to make the advanced calibration.

Plot Calibration Data

Check this function to have touch panel linearity comparison graph appear when you finish **Advanced Calibration**. The black lines reflect the ideal linearity assumed by PenMount's application program while the blue lines show the approximate linearity calculated by PenMount's application program as the result of user's execution of **Advance Calibration**.

Turn off EEPROM storage

This function disables the write-in of calibration data in **Controller**. This function is enabled by default.

Edge Compensation

This page is the edge compensation settings. You can adjust the settings from 0 to 30 for accommodating the difference of each touch panel.

About

This panel displays information about the PenMount controller and driver version.

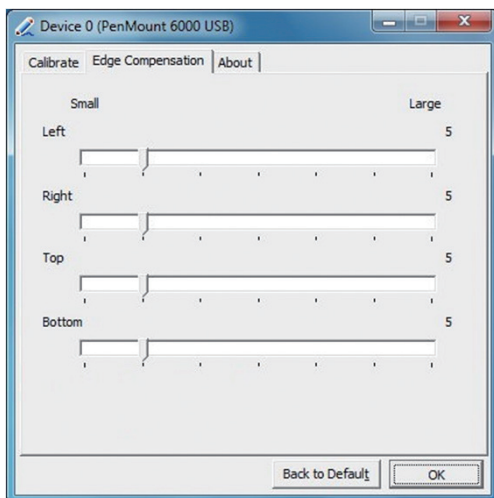
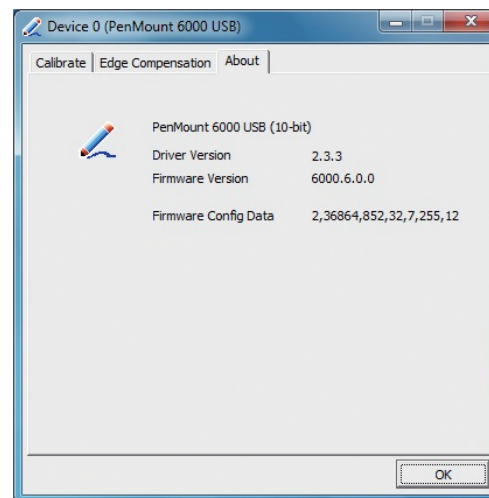

5.1.8 Uninstall PenMount Windows Universal Driver

1. Go to **Control Panel**. Click **"Add/Remove program"**. Select **"PenMount Universal Driver"**. Click **"Change/Remove"** button.

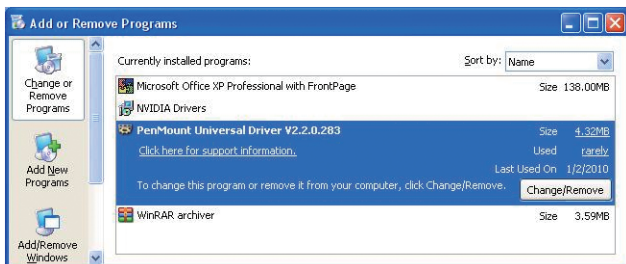

2. Select **'Uninstall'** to remove **PenMount Windows Universal Driver**.

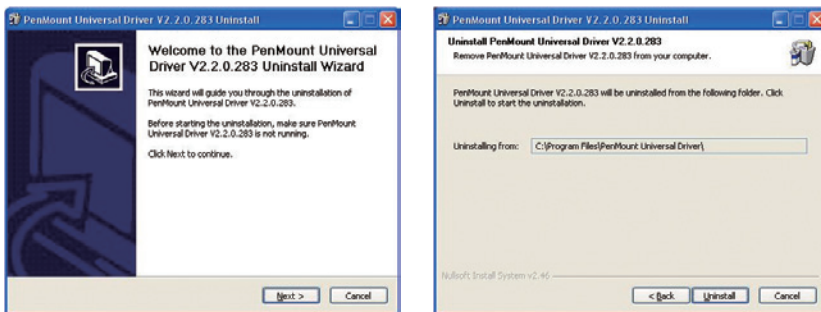

5.2 Install PenMount Linux X Window USB Driver

Before installing **PenMount Linux X Window USB Driver**, you must have had Linux X Window installed and running on your computer.

PenMount Linux X Window USB Drivers support the following operating systems:

	USB
Ubuntu 6.06/ 6.10/ 7.04/ 7.10/ 8.04/ 8.10/ 9.04/ 9.10/ 10.04/ 10.10/ 11.04/ 11.10/12.04 32_64bit	✓
Debian 4.0/ 5.0 32_64bit/ 6.0	✓
Debian 3.1	✗
Fedora 4/5/6/7/8/9/10/11/12/13 /14/15/16/17 32_64bit	✓
Fedora Core4_64bit	✗
Fedora Core3	✗
Fedora Core2	✗
Slackware12.0/12.1	✓
Slackware10.0	✗
Red Hat 9.0	✗
Red Hat 7.3/8.0	✓
OpenSuse 10.1/ 10.2/ 10.3/ 11/ 11.1/ 11.2/ 11.3/ 11.4/ 12.1 32_64bit	✓
Suse 10.0	✗
Suse 9.2/9.3	✗
Suse 8.0/9.0/9.1	✗

Cent OS 5.2/ 5.3/ 5.4/ 5.5/ 6.0/ 6.2 32_64bit	✓
Linux XFree86 4.x.x	✗
Linux XFree86 3.3.6	✗
Linux For GPM	✓
QNX 6.4.1/ 6.5	✓
QNX 6.3.2	✗
QNX 6.2	✗
Android	✓

5.2.1 Install PenMount Linux X Window USB Driver

See the readme file included in the driver folder.

5.2.2 Calibration Utilities

See the readme file included in the driver folder.

5.3 Install PenMount WinCE Driver

Before installing **PenMount WinCE Driver**, you must have WinCE system installed and running in your device.

5.3.1 Install PenMount WinCE Driver

Please see the readme file included in the driver folder.

CHAPTER 6: TOUCHSCREEN DRIVER SOFTWARE FUNCTIONS

This chapter will guide you to the special software functions that configure and adjust the PenMount controller and touchscreen hardware. Please note that not all of the functions are available for every driver. See the following table for drivers' software functions and their availability for specific interface and systems:

Software Function	DOS	2000/XP/2003	VISTA/7/8	WinCE	Linux
Standard Calibration	✓	✓	✓	✓	✓
Advanced Calibration		✓	✓	✓	✓
Multiple Monitors		✓	✓		
Multi Device		✓	✓		
Rotation		✓	✓		
Operation Mode		✓	✓		
Drawing mode	✓	✓	✓	✓	
Beep Sound	✓	✓	✓		✓
Beep sound adjustable		✓	✓		
Wake up function		✓	✓		
Showing linearity		✓	✓		
Right button		✓	✓	✓	✓
Hide cursor	✓				
Double click area and speed adjustable		✓	✓		
About		✓	✓		
Edge Compensation		✓	✓		
Refresh		✓	✓		

Remark: With PenMount Windows Universal V2.2.0.283 and later versions, since the touchscreen is automatically installed as a digitizer device in Windows Vista/7/8, the functions which are built within Windows Vista/ 7/ 8 such as rotation, multi-monitors, flicks, and context menu function (which launches a context menu by user's long-pressing on touchscreen rather than clicking the right-mouse button or pressing the application key on the keyboard) will be supported.

The following content in this chapter deals mainly with **PenMount Windows Universal Driver (for 2000/XP/2003/VISTA/7/8)**. For this driver, the function of **Tools** should be made known to you first. When you click the PenMount icon in the notification area and select “**Control Panel**” from the menu, “**PenMount Control Panel**” with the four tags “**Device**”, “**Multiple-Monitors**”, “**Tools**”, “**About**” will appear as the screenshot below:

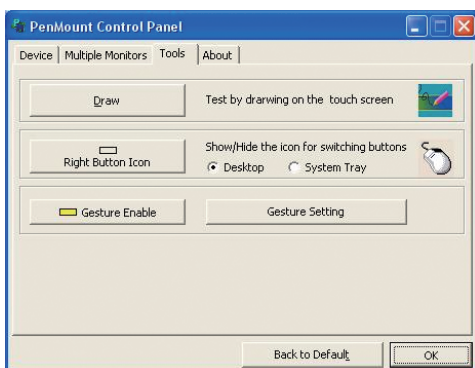
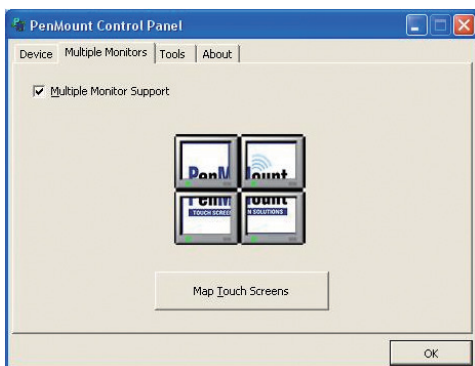

The buttons on such “**PenMount Control Panel**” have the following functions:

- | | |
|--------------------------------|--|
| Draw | Tests or demonstrates the PenMount touchscreen operation. |
| Right Button Icon | Enable right button function. The icon can show on Desktop or in the notification area . |
| Gesture Enable | Enable/configure Gesture AP to support PenMount gestures recognition. |
| Screen Rotation Monitor | The function supports nVidia , Intel , SMI or ATI and software such as Portrait Pivot Pro rotation automatic detection. |

6.1 Standard Calibration

Standard Calibration function lets you match the touchscreen to your display so that the point you touch is accurately tracked on screen. **Standard Calibration** only requires four points for calibration and one point for confirmation. Under normal circumstance **Standard Calibration** is all you need to perform an accurate calibration.

6.2 Advanced Calibration

Advanced Calibration function improves the accuracy of calibration by using more involved engineering calculations. Use this function only if you have tried the **Standard Calibration** and there is still a discrepancy in the way the touchscreen maps to the display. You can choose 9, 16 or 25 points to calibrate, though we suggest that you first try 9 points, if it is still not tracking well then try 16 or 25 points. The more points you use for calibration, the greater the accuracy. Errors in calibration may occur due to viewing angle, or individual skill, and there may be little difference in using 16 or 25 points. Note that a stylus is recommended for the most accurate results.

6.3 Rotation

There are currently a number of software packages on the market that support rotating monitors 0°, 90°, 180°, and 270°. However you will not be able to use a touchscreen unless it is matched to the appropriate rotation. Our rotation configuration function allows you to easily match the touchscreen when you rotate your monitor.

If you use a rotating monitor you will need a display card such as from **nVidia**, **Intel**, **SMI** or **ATI** and software such as **Portrait Pivot Pro**. For software operation and features, please refer to your software manual.

Configuring the rotation function is easy. Select this option and a 'point' appears for you to touch. Once the point is touched the software driver understands which degree you plan to rotate your display. The rotation function supports 90, 180 and 270 degrees rotation.

6.4 Draw

Tests or demonstrates the PenMount touchscreen operation. The display shows touch location. Click **Draw** to start. Touch the screen with your finger or a stylus and the drawing screen registers touch activity such **left**, **right**, **up**, **down**, **pen up**, and **pen down**.

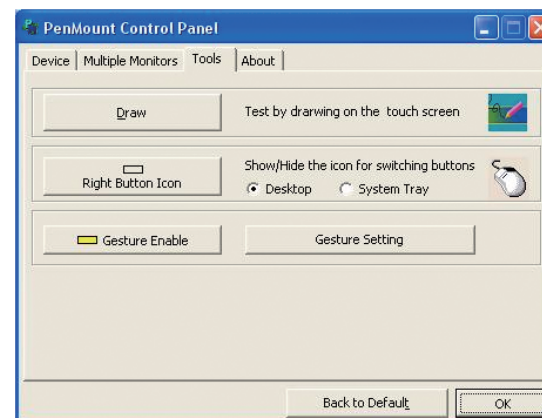

Touch the screen with your finger or a stylus and the drawing screen registers touch activity such **left**, **right**, **up**, **down**, **pen up**, and **pen down**.



Click **Menu** button for more functions.

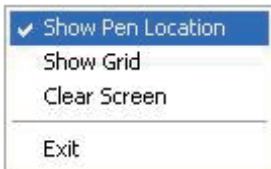

Show Pen Location is to show the locations where pen comes down and lifted up on the monitor.

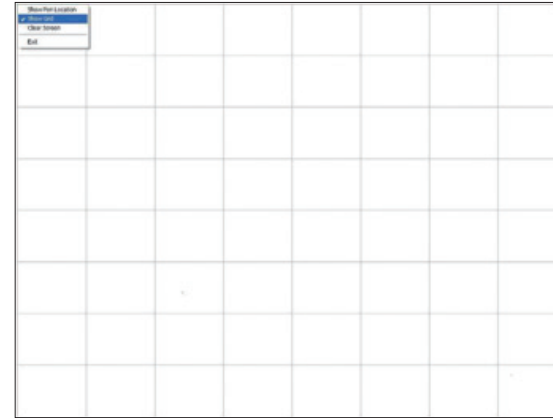

Show Grid is to show grid on the entire monitor. This is for linearity test.



Select **Clear Screen** to clear drawing.

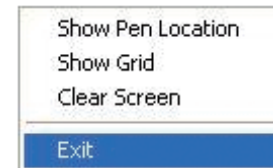

Select **Exit** to quit draw function.

6.5 Mouse Operation Mode

Mouse Operation Mode enables and disables mouse's ability of dragging onscreen icons, which is applicable to the configuration of POS terminals.

Pen Input Emulation	Select this mode and mouse will emulate Windows Vista pen input device operation, by which no mouse event will be sent until the touch is dragged out of range or released from the screen.
Mouse Emulation	Select this mode and mouse functions as normal and allows dragging of icons.
Click on Touch	Select this mode and mouse only provides a click function, and dragging is disabled.
Click on Release	Select this mode and mouse only provides a click function when the touch is released.

6.6 Beep Sound

All of PenMount's drivers support the beep sound function; however some PC systems may only offer a fixed buzzer sound.

6.7 Beep Sound Adjustable

Software drivers for Windows systems let the user adjust the frequency and length of the beep sound. The drivers let the user adjust the desired touchscreen sound, as well as turn the sound off.

6.8 Wake Up Function

Wake Up function lets the user touch the screen and wake the system up from 'suspend' mode.

6.9 Plot Calibration Data

Plot Calibration Data function displays the touchscreen linearity map, which is available if the PenMount driver provides an **Advance Calibration** function. When touchscreens age their touch linearity declines. This non-linearity is apparent when the touched point on the touchscreen is not the same as the point on the display. The **Plot Calibration Data** function shows the linearity status of the touchscreen. This is only a support function for the user. The exact linearity of a touchscreen requires a linearity test machine.

6.10 Right Button

Right Button function simulates the right button function of a mouse. Click the right button and the user can only touch the screen once and the driver changes the touch definition to the left button.

6.11 Hide Cursor

Hide Cursor function keeps the cursor arrow and other cursor symbols from appearing when using the touchscreen. The cursor appears when user turns this function off.

6.12 Cursor Offset

Cursor Offset function lets the user adjust the position of the touch point to a desired location away from the real touch point.

6.13 Double Click Area and Speed

Double Click Area and Speed function lets the user adjust the double click area and speed to their personal preference.

6.14 About

This option shows the exact version of the drivers and controller firmware. Updated drivers are available for downloading on the PenMount website at <http://www.penmount.com/>

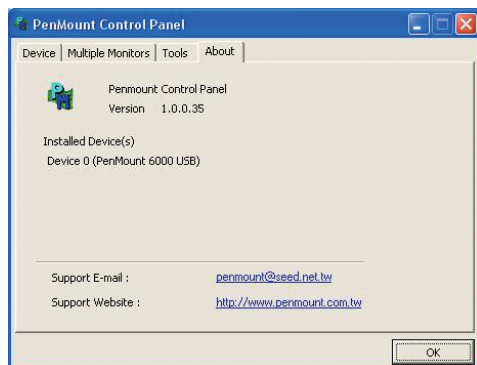

6.15 Edge Compensation

In PenMount **Control Panel**, when any of the detected PenMount device is selected and the **Configure** button is pressed, you will be able to see the **Edge Compensation** tag, which is for **Advanced Calibration**. You can adjust the settings from 0 to 30 for accommodating the difference of each touch panel. (Note: **Edge Compensation** is only supported by PenMount Windows Universal Driver (for Windows 2000/XP/2003/VISTA).)

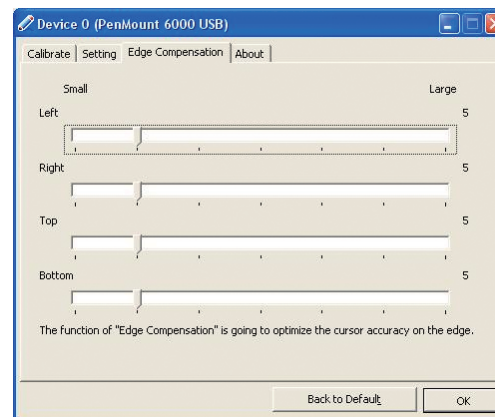

6.16 Refresh

If you installed PenMount driver package 2.1.0.187 and after, you can click the **Refresh** button on PenMount **Control Panel** to detect the newly attached PenMount devices. (Note: **Refresh** is only supported by PenMount Windows Universal Driver (for Windows 2000/XP/2003/VISTA).)

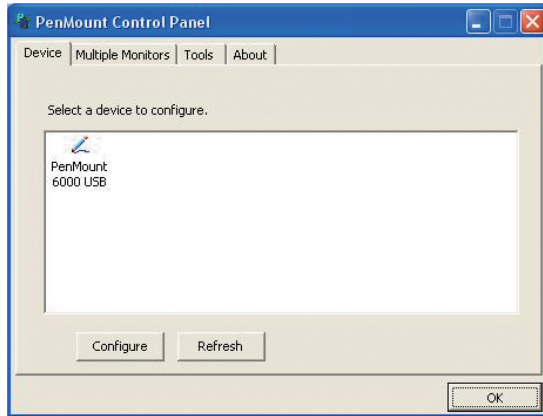

CHAPTER 7: PENMOUNT GESTURE AP FOR WINDOWS

This chapter will guide you to the PenMount Gesture AP that is applicable in Windows.

7.1 Invoke PenMount Gesture AP

1. To run PenMount Gesture AP.

In the notification, right-click on the PenMount icon and select **Gesture Enable** from the menu. A **PenMount Gesture AP** icon will show up in the notification area. See the illustration below. **PenMount Gesture AP** is running.

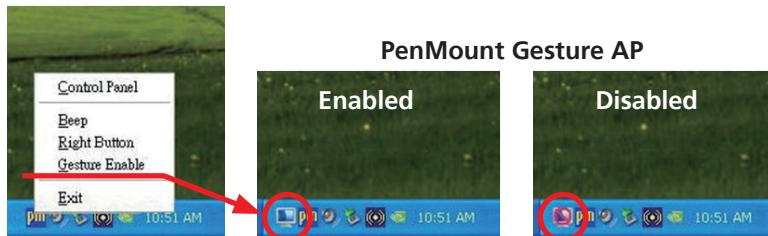

or

In **PenMount Control Panel**, select **Tools** tab and press **Gesture Enable** button. **PenMount Gesture AP** icon shows up in the notification area. **PenMount Gesture AP** is running.

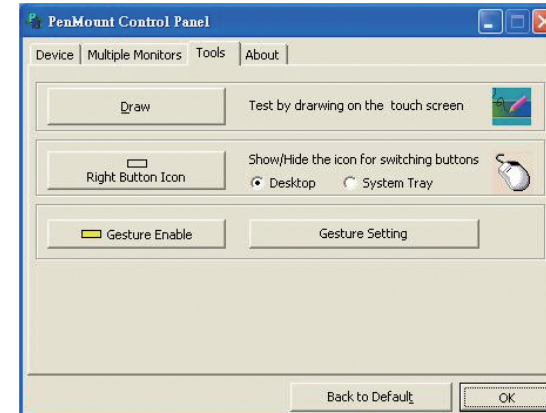

7.2 Configure PenMount Gesture AP

To configure PenMount Gesture AP.

1. Right-click on the **PenMount Gesture AP** icon in the notification area, select **Gesture Setting** from the menu that appears. See the illustration below.

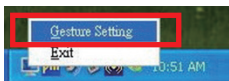

OR

- Select **Tools** tab and click **Gesture Setting** button in **PenMount Control Panel**.

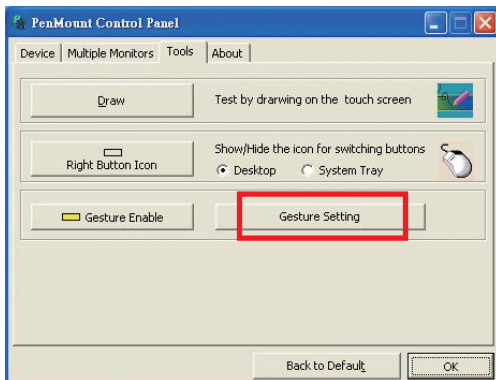

2. **[Gesture Setting]** window displays.

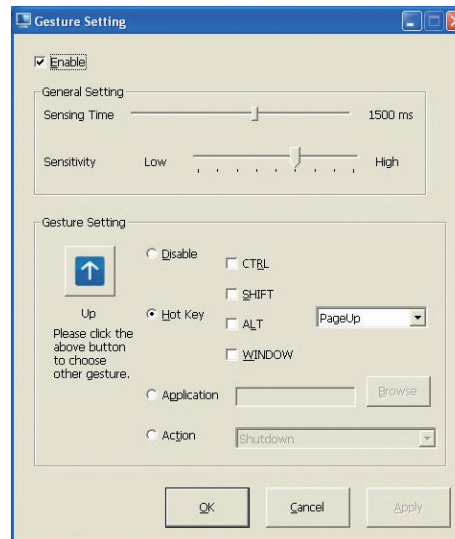

3. 15 **PenMount Gestures** are provided in total.

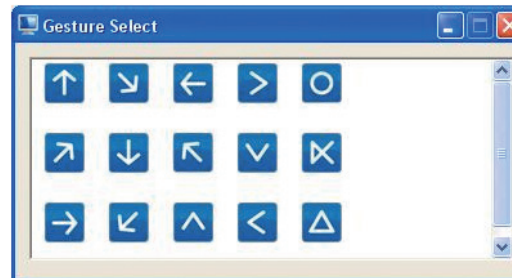

PenMount Gestures for Windows XP

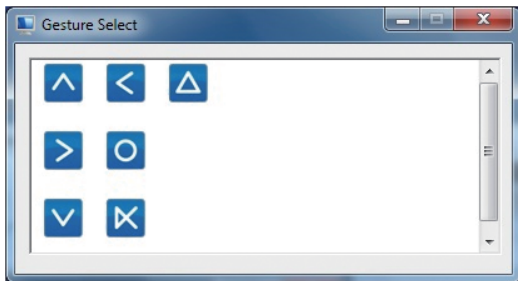

PenMount Gestures for Windows Vista / 7 / 8

In the **[Gesture Setting]** window, you can proceed to configure **PenMount Gesture AP**:

See picture below.

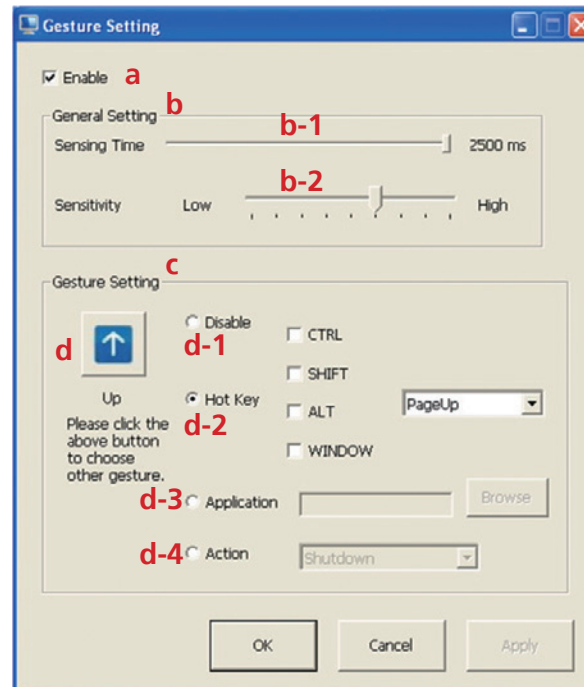

a.	Enable/disable Check Box. Select/deselect the box to enable/disable PenMount Gestures.							
b.	General Setting Box							
b-1.	Sensing Time - Move the slider to adjust PenMount Gestures Sensing Time between 200 ms (0.2 sec) and 2500 (2.5 sec). The shorter the sensing time is configured, the faster the gesture has to be done.							
b-2.	Sensitivity – Move the slider to adjust how sensitive you want your finger stroke on the touchscreen to be sensed.							
c	Gesture Settings Group Box. This group box allows you to individually configure each gesture.							
d	Gesture Select Button. Press this button to select the specific gesture you are going to configure. When the gesture icon turns to blue, it is enabled. When it is gray, it is disabled. See the following for details.							
d-1.	Disable Button. When this button is selected, the gesture is disabled.							
d-2.	Hot-key Configure Button. Configure the hot-keystrokes for specific gesture. The hot-key can include up to 5 keystrokes. When that gesture is sensed, the configured keystrokes will be reported.							
d-3.	Application Invoke Button. Configure to invoke a specific application with particular gesture. So that when the gesture is sensed, the specific application will run.							
d-4.	Action Configure Button. Configure to make use of PenMount Gesture AP's built-in shortcuts. So that when a particular gesture is sensed, a specific action will be taken. PenMount Gesture AP have the following shortcuts built in: <table border="1" style="display: inline-table; vertical-align: middle;"> <tr><td>Shutdown</td></tr> <tr><td>Send Right Mouse Click</td></tr> <tr><td>Send Middle Mouse Click</td></tr> <tr><td>Mouse Scroll Forward</td></tr> <tr><td>Mouse Scroll Backward</td></tr> <tr><td>Disable touch function</td></tr> <tr><td>Enable touch function</td></tr> </table>	Shutdown	Send Right Mouse Click	Send Middle Mouse Click	Mouse Scroll Forward	Mouse Scroll Backward	Disable touch function	Enable touch function
Shutdown								
Send Right Mouse Click								
Send Middle Mouse Click								
Mouse Scroll Forward								
Mouse Scroll Backward								
Disable touch function								
Enable touch function								

Note: For **Disable touch function**, after touch function is disabled, the mouse-pointer won't move following your finger sliding on the touchscreen and your finger tapping won't trigger any action, however, gestures will still be sensed.

(If you select Disable touch function, the cursor will not react to finger movement on the touch screen and the tapping will not trigger any program action. However, the gesture recognition is still functioning.)

7.3 PenMount Gestures' Default Values in Windows XP

	Page Up		Page Down
	Backward (Left Arrow)		Forward (Right Arrow)
	Copy (Ctrl + C)		Paste (Ctrl + V)
	Undo (Ctrl + Z)		Delete
	Zoom in ([Pad] +)		Zoom out ([Pad] -)
	Rotate Counter Clockwise (Ctrl + L)		Rotate Clockwise (Ctrl + K)
	Open On-Screen Keyboard (Execute OSK.EXE)		Save Document (Ctrl + S)
	Close Program (Alt + F4)		

CHAPTER 8: ENABLE A HIBERNATE ONCE/RESUME MANY

Environment by Using EWF

Please note that EWF is only available for VMC 1100 series. The following instructions help you easily enable the EWF function.

Please refer to the following link.

[https://msdn.microsoft.com/en-US/library/ff794943\(v=winembedded.60\).aspx](https://msdn.microsoft.com/en-US/library/ff794943(v=winembedded.60).aspx)

Here is all the syntax for EWF Manager (Standard 7 SP1)

[https://msdn.microsoft.com/en-US/library/ff794092\(v=winembedded.60\).aspx](https://msdn.microsoft.com/en-US/library/ff794092(v=winembedded.60).aspx)

CHAPTER 9: HOW TO INSTALL THE WWAN OR WI-FI MODULE

1. Remove the screws on the heatsink to remove it.



2. The Mini PCI express slot shown below is used to install a WWAN or Wi-Fi communication module.

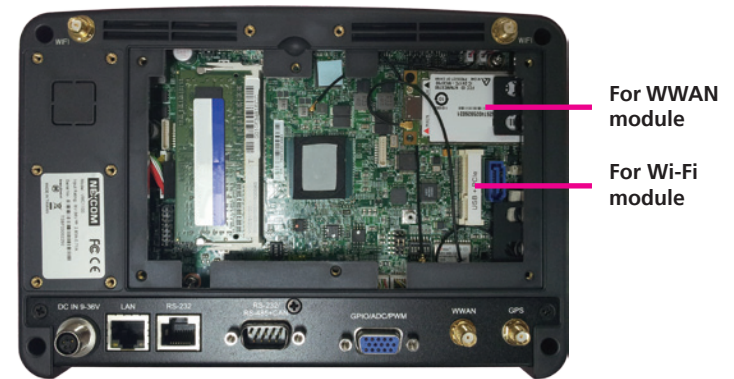

3. Insert the module into the Mini PCI Express slot at a 45 degree angle until the gold-plated connector on the edge of the module completely disappears inside the slot. And then attach the RF cable to the module.

4. Install the rear cover.

CHAPTER 10: HOW TO INSTALL A SATA DOM MODULE

1. Remove the heatsink.
2. When installing the Wi-Fi module, please install the module before installing the SATA DOM.
3. Before installing the SATA DOM, please make sure you have the following parts.

4. Paste the sponge on the Mini PCI express slot.



SATA DOM



Sponge



Thermal Pad

SATA Power
Cable

5. Plug the SATA power cable.



6. Plug the SATA DOM to the SATA connector and then connect the SATA power cable.



7. Paste the thermal pad on the SATA DOM board and then replace the heatsink cover.



CHAPTER 11: INSTALLING THE OBD MODULE

1. Remove the heatsink.
2. Remove the hole cover.

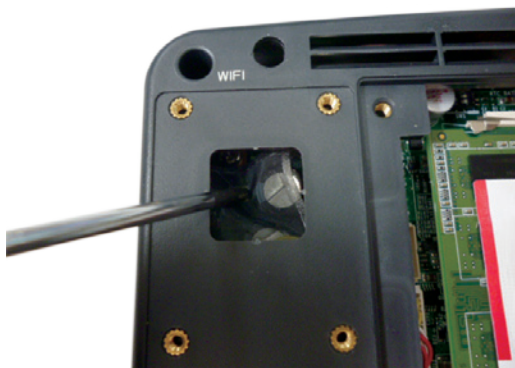
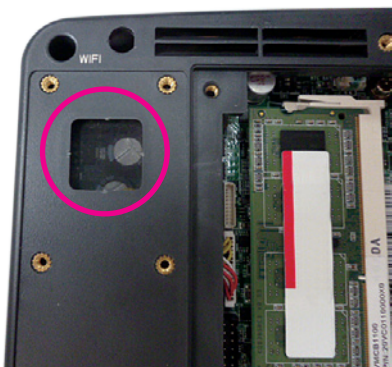

3. Put the OBD module into the bracket and secure it with screws.



4. Place the adapter board onto the OBD module, please note, the pins on the adapter board have to be inserted into the OBD module. Once fully inserted, secure the OBD module with screws.

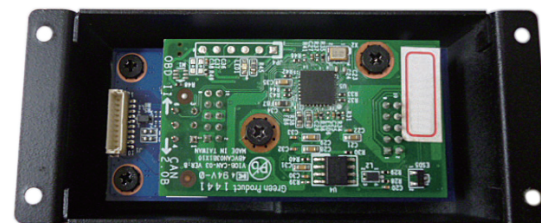

5. Connect the cable to the module.

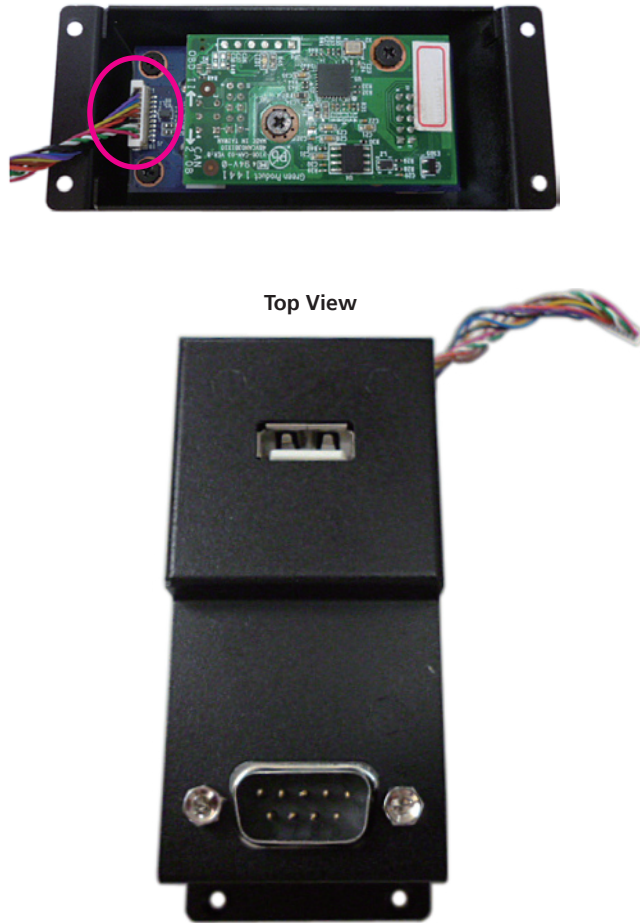

6. The cable passes through the hole and plugs to the connector.

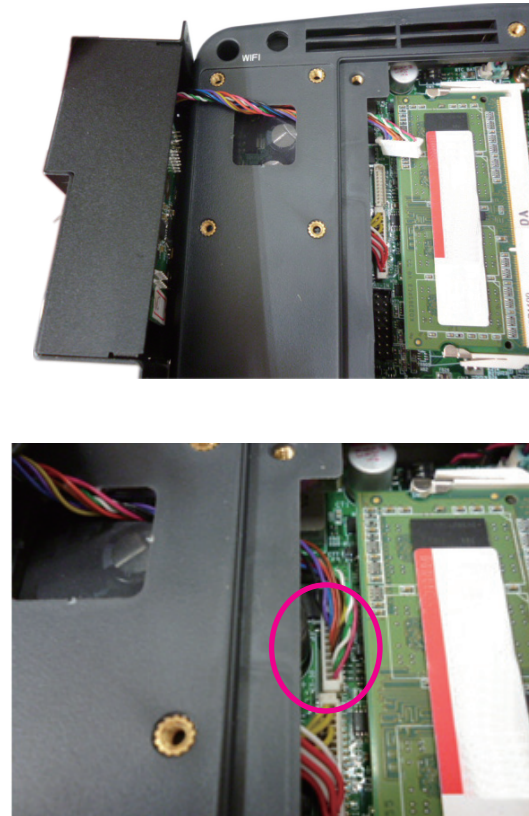

7. Secure the four screws to fix the module to the rear cover.

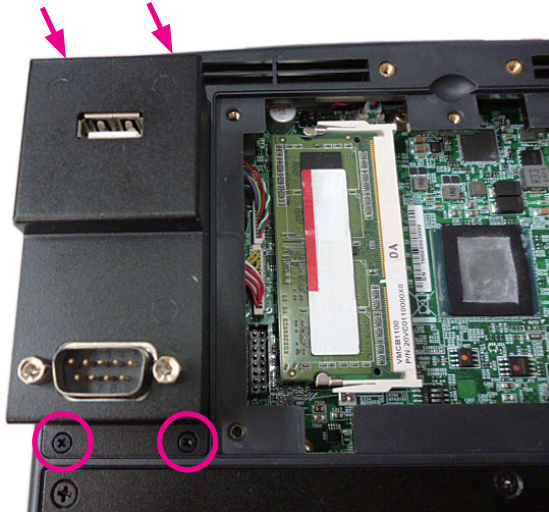

8. Place the heatsink back to its original location and secure it with screws.



APPENDIX A: I/O ADDRESS FUNCTION

IO ADDRESS:0EE0H~0EEFH

(*) for default setting

1. Ignition_status/ Battery_status/12V_status/

I/O port : 0EE0H

Bit 0: Reseverision

Bit 1: Reseverision

Bit 2: Ignition (read only)

0: OFF

1: ON

Bit 3: Status of Car Battery

0: Car Battery is OK

1: Car Battery is Low voltage

Bit 4: Status of +12V output

0: circuit normal(under 4A)

1: over circuit(over 4A)

Bit 5: Status of Car Battery bypass output

0: circuit normal(under 4A)

1: over circuit(over 4A)

Bit 4 and Bit 5: The action will delay 10ms~15ms

2. Capacity of NEXCOM battery (8 bits)

I/O port :0EE1H

	Bit 7	Bit 6	Bit 5	Bit 4	Bit 3	Bit 2	Bit1	Bit 0
Description	8 bits data (Bit 7 is highest bit of data)							

3. Voltage of NEXCOM battery (8 bits)

I/O port : 0EE2H

	Bit 7	Bit 6	Bit 5	Bit 4	Bit 3	Bit 2	Bit1	Bit 0
Description	8 bits data (Bit 7 is highest bit of data)							

4. Status of NEXCOM battery (8 bits)

I/O port : 0EE3H

Bit 0: Status for G sensor detection

0: Normal

1: Abnormal (X-axis or Y-axis degree is about 90 or -90)

Bit 1: POWER mode

0: 24V system

1: 12V system

Bit 2: Fan mode

0: auto

1: always on

Bit 3: status of smart battery

0: no discharging

1: discharging

Bit 4: status of FAN R?

0: well

1: failed

Bit 5: status of FAN R?

0: action

1: inaction

Bit 6: status of FAN L?

0: well

1: failed

Bit 7: status of FAN L?

0: action

1: inaction

5. GPIO

I/O port : 0EE4H

Bit0~3: GPO0~3

Bit4~7: GPIO~3

6. WDT

I/O port: 0EE5H

Bit3: WDT DISABLE\ENABLE

0: DISABLE(*)

1: ENABLE

BIT 2, 1, 0: time setting

BIT2~0	Time(sec)
000	1(*)
001	2
010	4
011	8
100	16
101	32
110	64
111	128

Auto clear WDT timer when read/write I/O port 0EE5H.

7. Onboard Module Disable/Enable(1)

I/O port : 0EE6H

Bit0: 3.5G MODULE

0: DISABLE

1: ENABLE (*)

Bit1: WLAN MODULE

0: DISABLE

1: ENABLE(*)

Bit2: EXTERNAL +12V power

0: DISABLE

1: ENABLE (*)

Bit3: By Pass Car battery power

0: DISABLE

1: ENABLE(*)

Bit4: Wake on 3.5G MODULE

0: DISABLE(*)

1: ENABLE

Bit5: Wake on RTC MODULE

0: DISABLE(*)

1: ENABLE

Bit6: Power on/off CAN BUS MODULE

0: OFF

1: ON (*)

Bit7: Status of COM PORT

0: CAN BUS(*)

1: MCU Download

8. Delay Time Setting

I/O port : 0EE7H

Bit7: Power On Delay

0: DISABLE(*)

1: ENABLE

Bit6: Power Off Delay

0: DISABLE(*)

1: ENABLE

Delay On Time Setting

BIT5~3	Time
000	10 sec
001	30 sec
010	1 min
011	5 min
100	10 min
101	15 min
110	30 min
111	1 hour

Delay Off Time Setting

BIT5~3	Time
000	10 sec
001	30 sec
010	1 min
011	5 min
100	10 min
101	15 min
110	30 min
111	1 hour

9. Startup and Shutdown Voltage Control

I/O port : 0EE8H

Only set by switch on motherboard(read only)

BIT3~2	Input Voltage
11	12V
10	24V
01	6~36V
00	6~36V

When input voltage 12V

BIT1~0	Input Voltage 12V	
00	Startup 11.5V	Shutdown 10.5V
01	Startup 12V	Shutdown 11V
10	Startup 12.5V	Shutdown 11V
11	Startup 12.5V	Shutdown 11.5V

When input voltage 24V

BIT1~0	Input Voltage 24V	
00	Startup 23V	Shutdown 21V
01	Startup 24V	Shutdown 22V
10	Startup 25V	Shutdown 22V
11	Startup 25V	Shutdown 23V

10. Setup Command

I/O port : 0EE9H

Restart the Setup Command

Enable byte
AA

Using end byte to tell the data flow end

Data	End byte
(Delay time)(Startup/Shutdown voltage setting)	55

11. Onboard CAN Module(Optional Module)

I/O port : 0EEAH

Bit1: Restart or Reset CANBUS Module

0: Don't care

1: RESET CAN Module

Bit4: CANBUS Data link detect

0: No data transfer

1: Data link (auto detect)

12. GAL Download control

I/O port: 0EEBH

Data	End byte
GAL CODE Download	AA



Note: Don't initialize this address

13. Startup Time Setting

I/O port: 0EECH (Clock timer)

Bit0~7: the hour value (hexadecimal)

I/O port: 0EEDH (Clock timer)

Bit0~7: the minute value (hexadecimal)

I/O port: 0EEEH (User setting time)

Bit0~7: the hour value (hexadecimal)

I/O port: 0EEFH (User setting time)

Bit0~7: the minute value (hexadecimal)

IO ADDRESS: 0ED0H~0EDFH

I/O port: 0ED0H addresses uses delivery internal data

1. MCU version byte (8 bits)

I/O port : 0EDEH

	Bit 7	Bit 6	Bit 5	Bit 4	Bit 3	Bit 2	Bit1	Bit 0
Description	8 bits data (Bit 7 is highest bit of data)							

2. GAL version byte (8 bits)

I/O port : 0EDFH

	Bit 7	Bit 6	Bit 5	Bit 4	Bit 3	Bit 2	Bit1	Bit 0
Description	8 bits data (Bit 7 is highest bit of data)							

G-sensor device I2C address: = 0x1D

0: circuit normal(under 4A)

1: over circuit(over 4A)

Datasheet download

1. G-sensor (ANALOG DEVICES - ADXL345-EP)

http://www.analog.com/static/imported-files/data_sheets/ADXL345-EP.pdf

Bit 5: Status of Car Battery bypass output

0: circuit normal(under 4A)

1: over circuit(over 4A)

IO ADDRESS: 0EE0H~0EEFH I/O port : 0EE0H

(* for default setting)

2. Ignition_status/ Battery_status/12V_status /

I/O port : 0EE0H

Bit 4 and Bit 5: The action will delay 10ms~15ms

Bit 0: Reseverision

Bit 1: Reseverision

Bit 2: Ignition (read only)

0: OFF

1: ON

Bit 3: Status of Car Battery

0: Car Battery is OK

1: Car Battery is Low voltage

Bit 4: Status of +12V output

2. Capacity of NEXCOM battery (8 bits)

I/O port: 0EE1H

	Bit 7	Bit 6	Bit 5	Bit 4	Bit 3	Bit 2	Bit 1	Bit 0
Description	8 bits data (Bit 7 is highest bit of data)							

3. Voltage of NEXCOM battery (8 bits)

I/O port: 0EE2H

	Bit 7	Bit 6	Bit 5	Bit 4	Bit 3	Bit 2	Bit 1	Bit 0
Description	8 bits data (Bit 7 is highest bit of data)							

4. Status of NEXCOM battery_VTK61B_20131105

I/O port : 0EE3H

Bit 0: Power Mode

0: 12V system

1: 24V system

Bit 1: Car Threshold

0: Low Level(10.5V/21V)

1: High Level(12V/24V)

Bit 2: Car Volt

0: Vin \geq Volt_Threshold_L(9V/20.5V)

1: Vin \leq Volt_Threshold_L(9V/20.5V)

Bit 3: Backup CAP

0: Battery capacity \geq 10%

1: Battery capacity \leq 10%

Bit 4: Output Type

0: Use Car Battery

1: Use Backup Battery

Bit 5: Bat Charge

0: Battery no charging

1: Battery is charging

Bit 6: Bat Discharge

0: Battery no discharging

1: Battery discharging

Bit 7: Temp Alarm

0: Battery no over temperature and $\geq 4^{\circ}\text{C}$

1: Battery over temperature and $\leq 4^{\circ}\text{C}$

5. GPIO

I/O port : 0EE4H

Bit0~3: GPO0~2

Bit4~7: GPIO~2

6. WDT

I/O port: 0EE5H

Bit3: WDT DISABLE\ENABLE

0: DISABLE(*)

1: ENABLE

BIT 3, 2, 1, 0: time setting

BIT3~0	Time(sec)
0000	1(*)
0001	2
0010	4
0011	8
0100	16
0101	32
0110	64
0111	128
1000	256

Auto clear WDT timer when read/write I/O port 0EE5H.

7. Onboard Module Disable/Enable(1)

I/O port : 0EE6H

Bit0: 3.5G MODULE

0: DISABLE

1: ENABLE (*)

Bit1: WLAN MODULE

0: DISABLE

1: ENABLE(*)

Bit2: EXTERNAL +12V power

0: DISABLE

1: ENABLE (*)

Bit3: By Pass Car battery power

0: DISABLE

1: ENABLE(*)

Bit4: Wake on 3.5G MODULE

0: DISABLE(*)

1: ENABLE

Bit5: Wake on RTC MODULE

0: DISABLE(*)

1: ENABLE

Bit6: Power on/off CAN/CAN2 BUS MODULE

0: OFF

1: ON(*)

Bit7: Status of COM PORT (for COM4 switch)

0: GPS (*)

1: MCU Download

8. Delay Time Setting

I/O port : 0EE7H

Bit7: Power On Delay

0: DISABLE(*)

1: ENABLE

Bit6: Power Off Delay

0: DISABLE(*)

1: ENABLE

Delay On Time Setting

BIT5~3	Time
000	10 sec
001	30 sec
010	1 min
011	5 min
100	10 min
101	15 min
110	30 min
111	1 hour

Delay Off Time Setting

BIT2~0	Time
000	20 sec
001	1 min
010	5 min
011	10 min
100	30 min
101	1 hour
110	6 hour
111	18 hour

9. Startup and Shutdown Voltage Control

I/O port : 0EE8H

Only set by switch on motherboard(read only)

BIT3~2	Input Voltage
11	12V
10	24V
01	6~36V
00	6~36V

When input voltage 12V

BIT1~0	Input Voltage 12V
00	Startup Shutdown 11.5V 10.5V
01	Startup Shutdown 12V 11V
10	Startup Shutdown 12.5V 11V
11	Startup Shutdown 12.5V 11.5V

When input voltage 24V

BIT1~0	Input Voltage 24V
00	Startup Shutdown 23V 21V
01	Startup Shutdown 24V 22V
10	Startup Shutdown 25V 22V
11	Startup Shutdown 25V 23V

10. Setup Command

I/O port : 0EE9H

Restart the Setup Command

Enable byte
AA

Using end byte to tell the data flow end

Data	End byte
(Delay time)(Startup/Shutdown voltage setting)	55

11. Onboard CAN Module(Optional Module)

I/O port : 0EEAH

Bit1: Restart or Reset CANBUS Module

- 0: Don't care
- 1: RESET CAN Module

Bit2: CAN2_DI Data link detect

- 0: No data transfer
- 1: Data link (auto detect)

Bit4: CANBUS Data link detect

- 0: No data transfer
- 1: Data link (auto detect)

Bit5: CAN2_DO Data link detect

- 0: No data transfer
- 1: Data link (auto detect)

12. GAL Download control

I/O port: 0EEBH

Data	End byte
GAL CODE Download	AA



Note: Don't initialize this address

13. Startup Time Setting

I/O port: 0EECH (Clock timer)

Bit0~7: the hour value (hexadecimal)

I/O port: 0EEDH (Clock timer)

Bit0~7: the minute value (hexadecimal)

I/O port: 0EEEH (User setting time)

Bit0~7: the hour value (hexadecimal)

I/O port: 0EEFH (User setting time)

Bit0~7: the minute value (hexadecimal)

IO ADDRESS: 0ED0H~0EDFH

I/O port: 0ED0H addresses uses delivery internal data

1. MCU version byte (8 bits)

I/O port : 0EDEH

	Bit 7	Bit 6	Bit 5	Bit 4	Bit 3	Bit 2	Bit 1	Bit 0
Description	8 bits data (Bit 7 is highest bit of data)							

2. GAL version byte (8 bits)

I/O port : 0EDFH

	Bit 7	Bit 6	Bit 5	Bit 4	Bit 3	Bit 2	Bit 1	Bit 0
Description	8 bits data (Bit 7 is highest bit of data)							

IO ADDRESS: I/O port: 0ED1H

Bit0: WLAN2_DIS

0: Disable

1: Enable (*)

Bit1: GPS_PWR_EN

0: Disable

1: Enable (*)

Bit2: Modem_PWR_EN

0: ON (*)

1: OFF

Bit3: Modem_SEL

0: ON (*)

1: OFF

Bit4: COM2 RS485/RS422

0: COM2 RS485 (*)

1: COM2 RS422

Bit5: COM2 RS232 / RS485_RS422

0: COM2 RS232 (*)

1: COM2 RS485/RS422

IO ADDRESS: I/O port: 0EDCH

Bit 5-7: Type

000: VTC

001: VMC

010: nROK

Bit 0-4: Model

Bit 0-4: 00001

Bit 5-7: 001

APPENDIX B: VEHICLE POWER MANAGEMENT SETUP

External Power Output Setting

External +12V and +5V Turn On Simultaneously

External +12V and +5V Turn Off Simultaneously

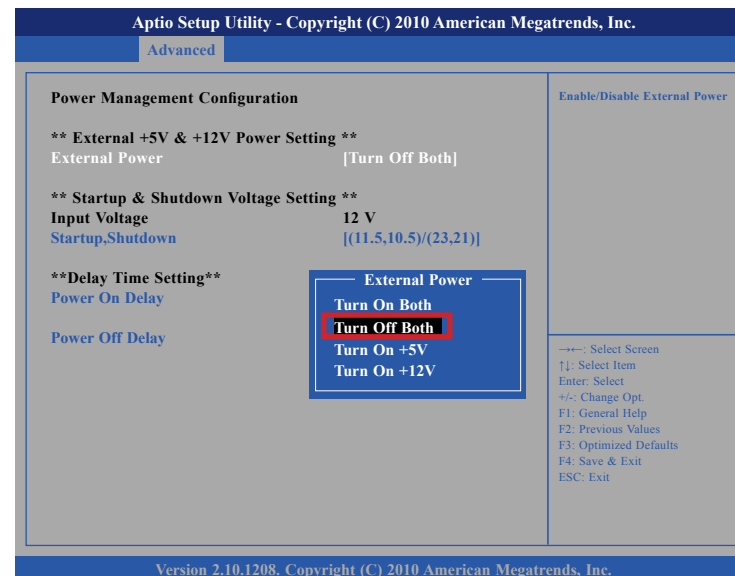
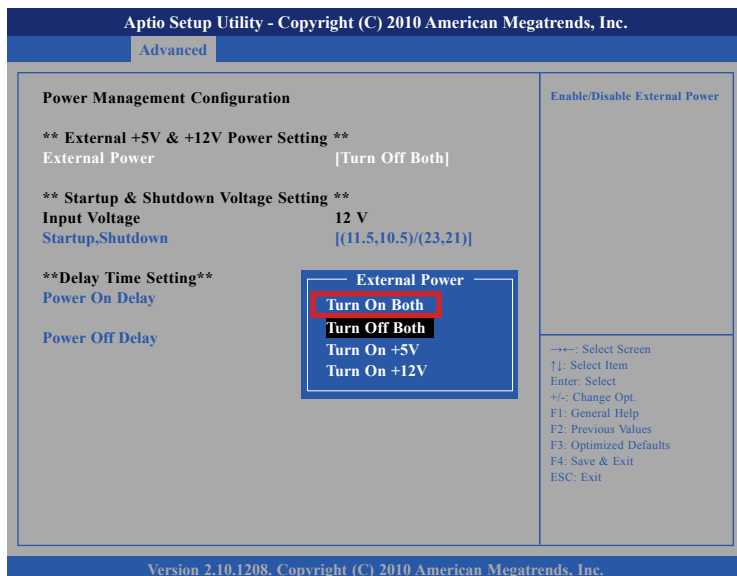

Vehicle Power Management Setup

External Power Output Setting

External +12V Turn On Only

Aptio Setup Utility - Copyright (C) 2010 American Megatrends, Inc.

Advanced

Power Management Configuration

**** External +5V & +12V Power Setting ****
External Power [Turn Off Both]

**** Startup & Shutdown Voltage Setting ****
Input Voltage 12 V
Startup,Shutdown [(11.5,10.5)/(23,21)]

****Delay Time Setting****
Power On Delay

Power Off Delay

External Power

Turn On Both
Turn Off Both
Turn On +5V
Turn On +12V

--- Select Screen
[1]: Select Item
Enter: Select
+/-: Change Opt.
F1: General Help
F2: Previous Values
F3: Optimized Defaults
F4: Save & Exit
ESC: Exit

Enable/Disable External Power

Version 2.10.1208. Copyright (C) 2010 American Megatrends, Inc.

External +5V Turn On Only

Aptio Setup Utility - Copyright (C) 2010 American Megatrends, Inc.

Advanced

Power Management Configuration

**** External +5V & +12V Power Setting ****
External Power [Turn Off Both]

**** Startup & Shutdown Voltage Setting ****
Input Voltage 12 V
Startup,Shutdown [(11.5,10.5)/(23,21)]

****Delay Time Setting****
Power On Delay

Power Off Delay

External Power

Turn On Both
Turn Off Both
Turn On +5V
Turn On +12V

--- Select Screen
[1]: Select Item
Enter: Select
+/-: Change Opt.
F1: General Help
F2: Previous Values
F3: Optimized Defaults
F4: Save & Exit
ESC: Exit

Enable/Disable External Power

Version 2.10.1208. Copyright (C) 2010 American Megatrends, Inc.

Vehicle Power Management Setup

Startup and Shutdown Voltage Setting



1.

If the input voltage setting is 12V :
 set the startup voltage to 11.5V and the shutdown voltage to 10.5V.

If the input voltage setting is 12V :
 set the startup voltage to 12V and the shutdown voltage to 11V.

If the input voltage setting is 12V :
 set the startup voltage to 12.5V and the shutdown voltage to 11.5V.

If the input voltage setting is 12V :
 set the startup voltage to 12.5V and the shutdown voltage to 11V.

Vehicle Power Management Setup

Startup and Shutdown Voltage Setting



2.

If the input voltage setting is 24V :
 set the startup voltage to 23V and the shutdown voltage to 21V.

If the input voltage setting is 24V :
 set the startup voltage to 24V and the shutdown voltage to 22V.

If the input voltage setting is 24V :
 set the startup voltage to 25V and the shutdown voltage to 22V.

If the input voltage setting is 24V :
 set the startup voltage to 25V and the shutdown voltage to 23V.

Vehicle Power Management Setup

Startup and Shutdown Voltage Setting

Aptio Setup Utility - Copyright (C) 2010 American Megatrends, Inc.

Advanced

Power Management Configuration	Startup,Shutdown Setting
** External +5V & +12V Power Setting **	
External Power	[Turn Off Both]
** Startup & Shutdown Voltage Setting **	
Input Voltage	6-36V
Startup,Shutdown	[(11.5,10.5)/(23,21)]
Delay Time Setting	
Power On Delay	[Disable]
Power Off Delay	[Disable]
→←: Select Screen ↑↓: Select Item Enter: Select +/-: Change Opt. F1: General Help F2: Previous Values F3: Optimized Defaults F4: Save & Exit ESC: Exit	

Version 2.10.1208. Copyright (C) 2010 American Megatrends, Inc.

4.

If the input voltage setting is 6v~36V ignore the startup/shutdown setting.

Vehicle Power Management Setup

Power-on Delay Setting

Disable Power-on Delay

Aptio Setup Utility - Copyright (C) 2010 American Megatrends, Inc.

Advanced

Power Management Configuration		Options
** External +5V & +12V Power Setting **		11.5V , 10.5V
External Power	[Turn On Both]	12.0V , 11.0V
** Startup & Shutdown Voltage Setting **		12.5V , 11.0V
Input Voltage	12V	12.5V , 11.5V
Startup,Shutdown	[11.5V , 10.5V]	
Delay Time Setting		
Power On Delay	[Disabled]	
Power Off Delay	[Disabled]	

→←: Select Screen
↑↓: Select Item
Enter: Select
+/-: Change Opt.
F1: General Help
F2: Previous Values
F3: Optimized Defaults
F4: Save & Exit
ESC: Exit

Version 2.10.1208. Copyright (C) 2010 American Megatrends, Inc.

Enable Power-on Delay

Delay time can be set at 10sec/30sec/1min./5min./10min./15min./30min./1hour.

Input Voltage	[48V]	10 min
Startup,Shutdown	[46V , 44V]	15 min
		30 min
		1 hour
Delay Time Setting		
Power On Delay	[Enabled]	
Delay On Time selection	[10 sec]	
Power Off Delay	[Disabled]	

→←: Select Screen
↑↓: Select Item
Enter: Select
+/-: Change Opt.
F1: General Help



External Power	[Turn On Both]	30 sec
		1 min
		5 min
		10 min
		15 min
		30 min
		1 hour
** Startup & Shutdown Voltage Setting **		
Input Voltage	10 sec	
Startup,Shutdown	30 sec	
	1 min	
	5 min	
	10 min	
	15 min	
	30 min	
	1 hour	
Delay Time Setting		
Power On Delay		
Delay On Time selection		
Power Off Delay		

→←: Select Screen
↑↓: Select Item
Enter: Select
+/-: Change Opt.
F1: General Help
F2: Previous Values

Vehicle Power Management Setup

Power-on Delay Setting

Disable Power-off Delay

Aptio Setup Utility - Copyright (C) 2010 American Megatrends, Inc.

Advanced

Power Management Configuration		Options
** External +5V & +12V Power Setting **		11.5V , 10.5V 12.0V , 11.0V 12.5V , 11.0V 12.5V , 11.5V
External Power	[Turn On Both]	
** Startup & Shutdown Voltage Setting **		
Input Voltage	12V	
Startup,Shutdown	[11.5V , 10.5V]	
Delay Time Setting		
Power On Delay	[Disabled]	
Power Off Delay	[Disabled]	

→←: Select Screen
↑↓: Select Item
Enter: Select
+/-: Change Opt.
F1: General Help
F2: Previous Values
F3: Optimized Defaults
F4: Save & Exit
ESC: Exit

Version 2.10.1208. Copyright (C) 2010 American Megatrends, Inc.

Enable Power-off Delay

Delay time can be set at 20sec/1min./5min./10min./30min./1hour/6hour/18hour.

Delay Time Setting		6 hour 18 hour
Power On Delay	[Enabled]	
Delay On Time selection	[10 sec]	
Power Off Delay	[Enabled]	
Delay Off Time selection	[20 sec]	

→←: Select Screen
↑↓: Select Item
Enter: Select
+/-: Change Opt.
F1: General Help



External Power	[Turn On Both]	1 min 5 min 10 min 30 min 1 hour 6 hour 18 hour
** Startup & Shutdown Voltage Setting **		
Input Voltage		
Startup,Shutdown		
Delay Time Setting		
Power On Delay		
Delay On Time selection		
Power Off Delay		
Delay Off Time selection		

→←: Select Screen
↑↓: Select Item
Enter: Select
+/-: Change Opt.
F1: General Help
F2: Previous Values

APPENDIX C: SMS AND DIAL WAKE-UP SETTING

Utilizing sleep mode on the Cinterion PHS8 3.5G module and allowing for remote wake up via SMS or dial.

A. BIOS setting

- (1) Press <Enter> on "Advanced" of the main menu screen.
- (2) Select "Module Management."

- (3) Change the value to "Enable" for "Wake On 3.5G Module."

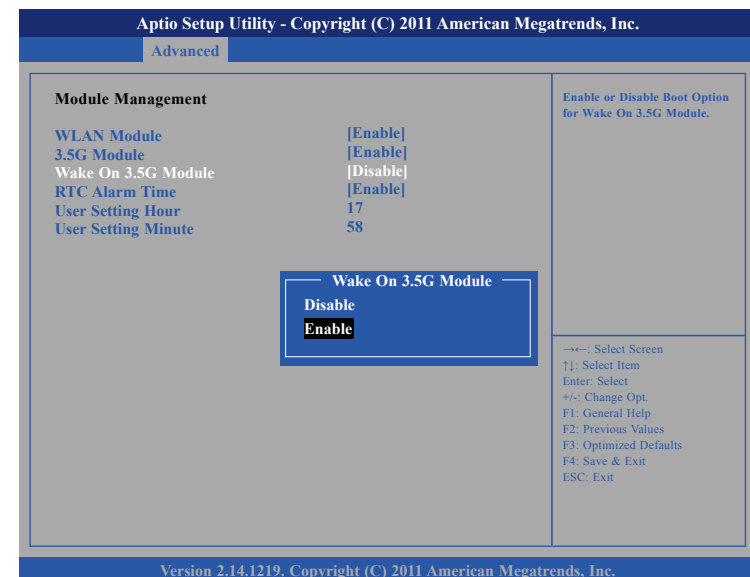
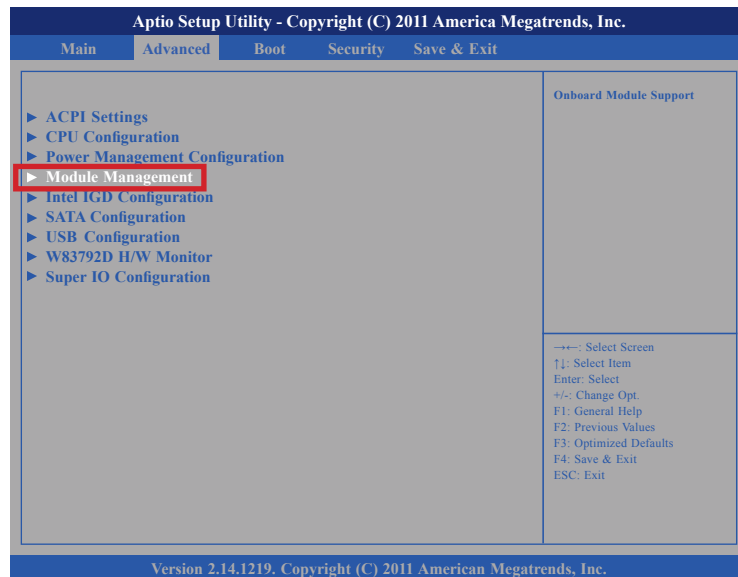

APPENDIX D: RTC WAKE-UP SETTING

(1) Press <Enter> on “Advanced” of the main menu screen.

(2) Select “Module Management.”

(3) Change the value to “Enable” for “RTC Alarm Time.”



(4) You can key in the value for "User Setting Hour" (0~23) and "User Setting Minute" (0~59).

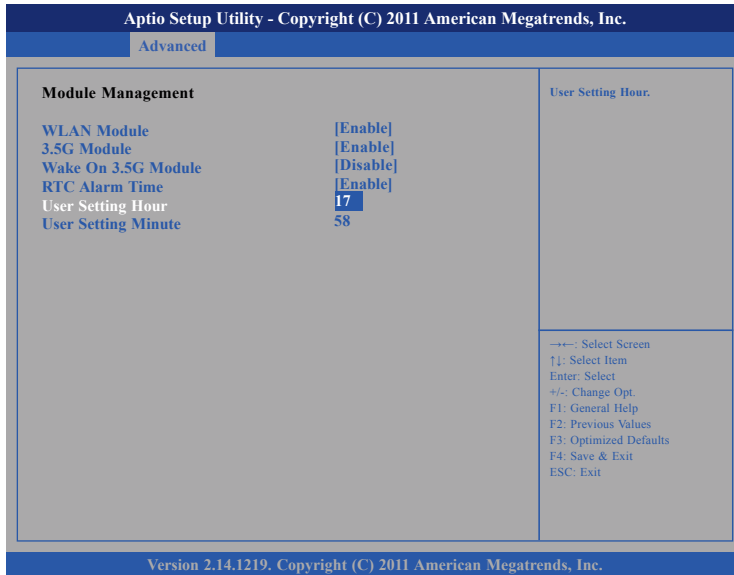

(5) After you have finished with the Setup, press <ESC> to go back to the main menu and then press "Enter" on "Save Changes and Reset."

APPENDIX E: AUTO BACKLIGHT SETTING

- (1) Press <Enter> on "Advanced" of the main menu screen.
- (2) Select "Intel IGD Configuration."

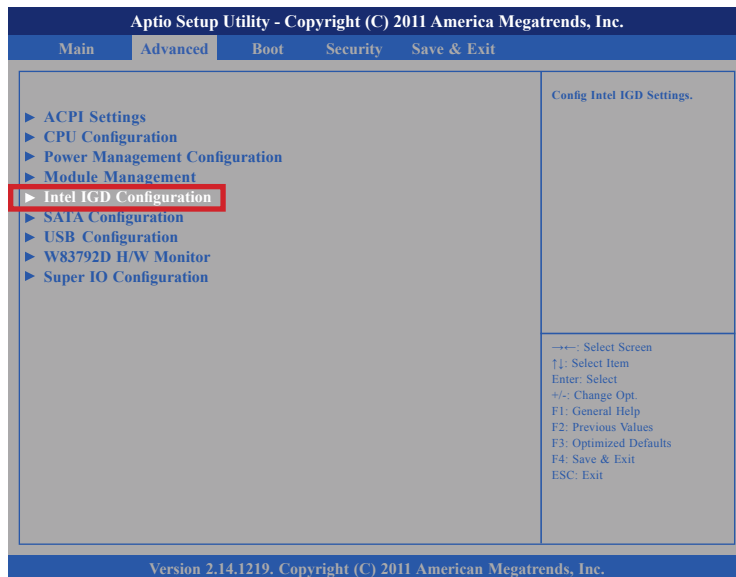

- (3) Change the value to "Enable" for "Auto-BackLight Select."

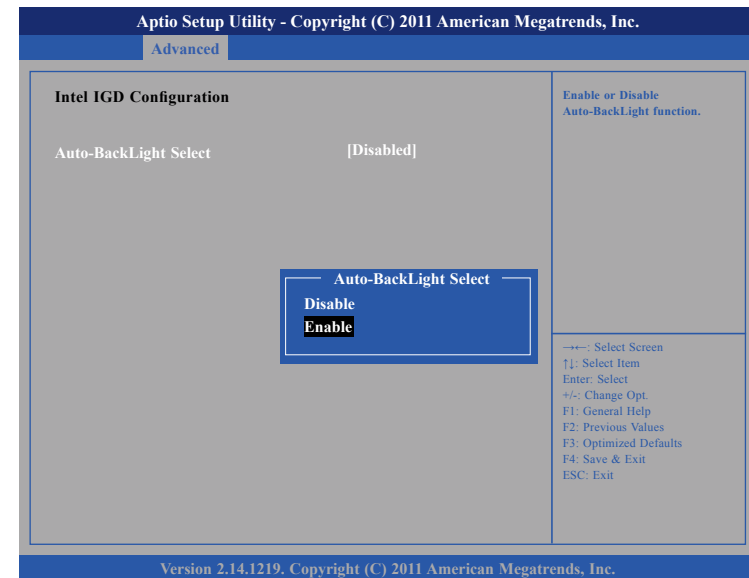

- (4) After you have finished with the Setup, press <ESC> to go back to the main menu and then press "Enter" on "Save Changes and Reset."

After the setup procedure is completed, the light sensors can auto-adjust a display's backlight.

APPENDIX F: BIOS UPDATE

- (1) Locate the "afuwin32" setup file in the "afuwin32" folder.
- (2) Start the "afuwingui" setup program.

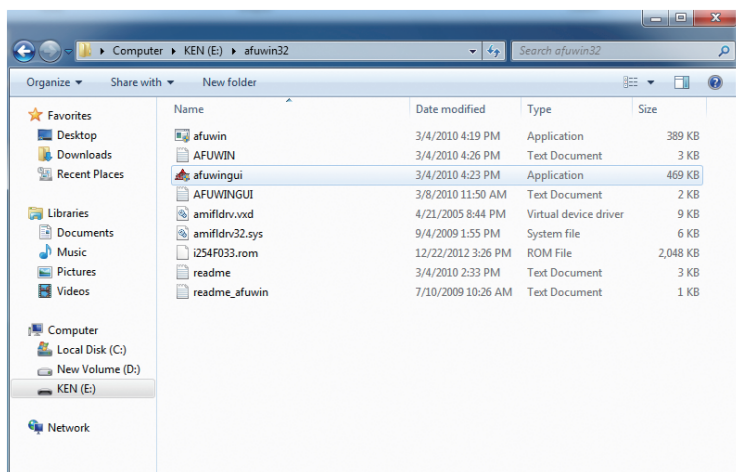

- (3) Press the "OK" button when prompted with a pop-up window.

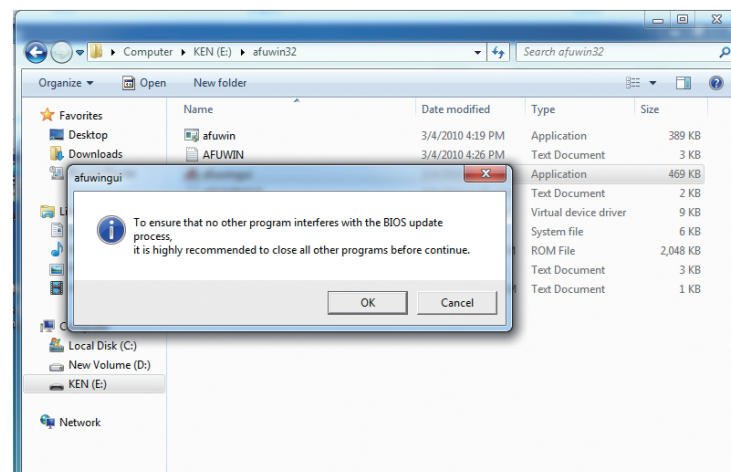

(4) Press the “Open” button.

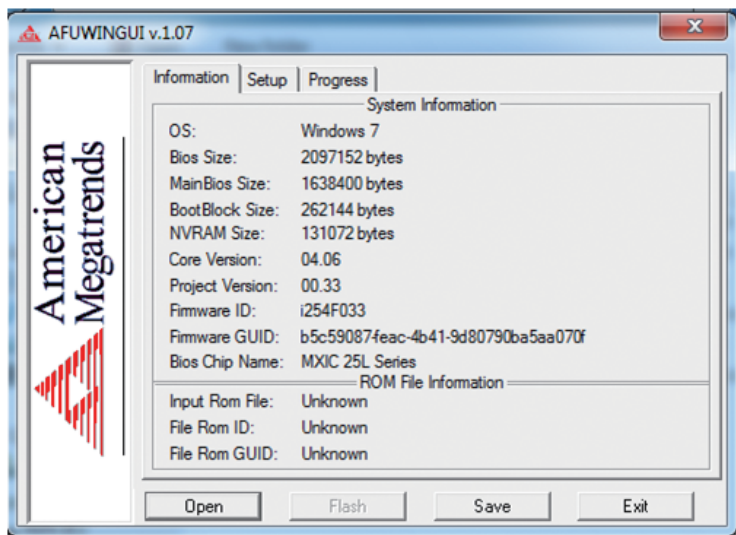

(5) Select the BIOS file.

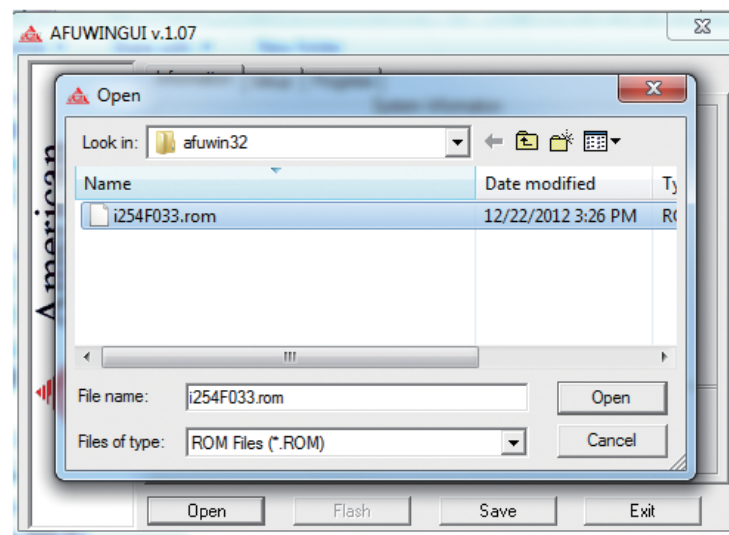

(6) Check all the options in “Block Options” and then press the “Flash” button.

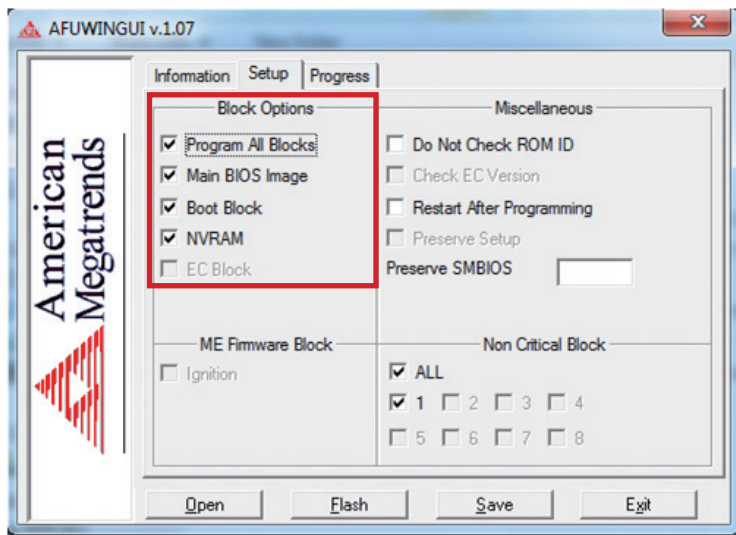

(7) The BIOS will be updated automatically, when the update is completed, please restart the VMC.

