



VMC 110



VMC 111

Main Features

- 7" 1024 x 600 TFT LCD monitor with resistor touch screen
- ARM® Cortex®-A9 Dual Core Processor with 1GHz frequency
- Compact and fanless design
- On screen F1 ~ F5 programmable function keys
- Linux and Android operating system
- GPS/Wi-Fi/3G/LTE supported (optional)
- Dead Reckoning & Battery (optional)
- Dual CAN Bus 2.0B
- OBDII (ISO15765-4)/SAE J1939 (optional)
- Wide Range DC input from 9 ~ 36V
- CE/FCC/eMark

Product Overview

VMC 110/111, a 7-inch all in one mobile data terminal, targets the fleet management, transportation and logistic applications. Its compact and rugged design with flexible expansion capability is perfect to the limited space on the driver cabinet and strog requirement on the wireless communication. VMC110/111 has various options on GPS, Dead Reckoning, Wifi, 3G and LTE. Besides, VMC 110/111 works on the both of Android and Linux operating systems. 7" 1024 x 600 resolution with 400nits brightness and resistive touch is suitable on the driver cabinet. Abundant I/O support, such as 2 x CAN bus 2.0B, OBDII/J1939, RS232, RS485, USB, GPIO, LAN... can help to get vehicle information and connect with different sensors or equipment.

Specifications

LCD Panel

- 7-inch TFT LCD Panel with LED Backlight
- 1024 x 600 pixels
- Brightness: 500 cd/m² (typical)
- Contrast ratio: 800:1 (typical)
- Viewing angle: 150(H), 145(V)

Touch Screen

- 4-wire resistant touch
- Anti-glare coating surface
- Transmission rate: 80% ± 3%

CPU & Chipset

- ARM® Cortex®-A9 Processor with 1GHz frequency
- Freescale Dual Core

Memory

- On-board DDR3L 2GB

Storage

- 1 x Micro SDHC Slot
- EMMC: 8G on board

Expansion

- 1 x half-size mini-PCIe (PCIe + USB) for WLAN
- 1 x full-size mini-PCIe (USB + UART) for WWAN
- OBDII: ISO15765-4 & SAE J1939 (Default: None, BOM optional)
- Battery (optional)

I/O Interface-Front

- F1 ~ F5 programmable function keys
- Light Sensor
- Internal Mic-in
- 2 x Built-in 2W speakers
- 3 x LED indicators (Power, Storage and WWAN)

I/O Interface-Lateral

- Right side
 - 1 x SIM card slot
 - 1 x Micro SD card slot
 - 1 x USB 2.0 type A
 - 1 x micro USB OTG for maintenance
- Left side
 - 1 x Power button
 - 1 x Volume up/down
 - 1 x Brightness up/down
 - 1 x System reset button

I/O Interface-Rear/Bottom

- 1 x lockable power input with ignition
- 1 x RJ45 for LAN
- 2 x USB 2.0 Type A
- DB-15 connector
 - Full RS-232
 - RS-232/485
 - CAN1 2.0B

Dimension Drawing

VMC 110

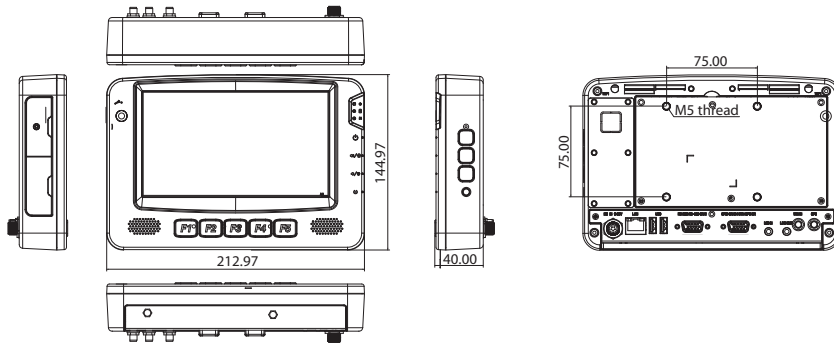

VMC 111

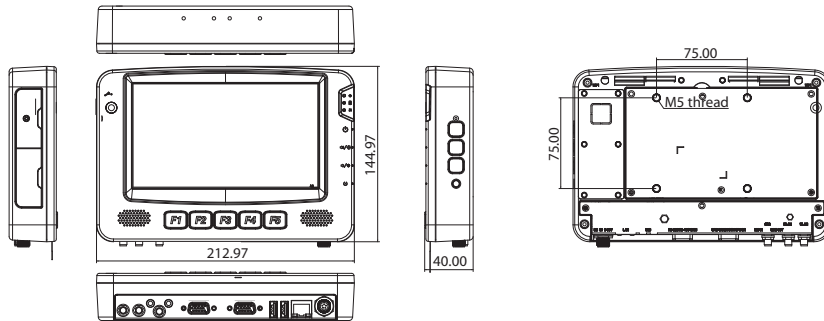

- ♦ DB-15 connector
 - GPI x 3
 - Sink type: 5VDC TTL (default)
 - Source type: 3 ~ 28VDC
 - GPO x 3
 - Sink type: 5VDC TTL (default), max current: 20mA
 - Source type: 3 ~ 28VDC, max. current: 150mA
 - GPS DR (Speed, direction, GND)
 - CAN2 2.0B (Default) & (BOM optional for OBD II (ISO 15765-4 & J1939))
 - iButton
- ♦ 1 x Mic-in
- ♦ 1 x Line-out
- ♦ 3 x Antenna on I/O
 - Rear: 1 x GPS, 1 x WWAN
 - Bottom: 1 x GPS, 2 x WWAN
- ♦ 2 x Antenna on housing for Wi-Fi

Mechanical

- ♦ Cooling System: Fanless
- ♦ Enclosure: Plastic PC/ABS + Metal heat-sink
- ♦ Mounting: VESA 75/100 & Desktop mounting
- ♦ Ingress Protection: Front panel IP54
- ♦ Dimension: 212.9mm (W) x 144.97mm (H) x 40mm (D)(8.4" x 5.7" x 1.6")
- ♦ Weight: 1.3kg

Power Management

- ♦ 9V~36V DC input
- ♦ Selectable boot-up & shut-down voltage
- ♦ Ignition: 8-level delay time on/off
- ♦ Reverse protection/over-voltage protection/low-voltage protection
- ♦ Wake up by SMS/RTC/ignition
- ♦ UPS Battery (optional)

Operating System

- ♦ Linux YOCTO 2.0 by Request
- ♦ Android 5.1

Environment

- ♦ Operating temperatures: Ambient with air -20°C to 70°C
- ♦ Storage temperatures: -30°C to 80°C
- ♦ Relative humidity: 10% to 90% (non-condensing)
- ♦ Vibration
 - Vibration test: IEC 60068-2-64, 2.5G
 - Operating: MIL-STD-810G, 514.6 Procedure 1, Category 4
 - Storage: MIL-STD-810G, 514.6 Procedure 1, Category 24
- ♦ Shock
 - MIL-STD-810G, 516.6 Procedure 1, trucks and semi-trailers=40g
 - Crash hazard: MIL-STD-810G, Method 516.6, Procedure V, ground equipment=75g

Certification

- ♦ CE/FCC class B/eMark

Ordering Information

♦ VMC 110 (P/N: 10VC0110005X0)

VMC 110-D1A 7" I/O on the back w/i.MX6 Dual Lite, 2GB, 8G EMMC, 4w T/S, Android

♦ VMC 111 (P/N: 10VC0111000X0)

VMC 111-D1A 7" I/O on the bottom w/i.MX6 Dual Lite, 2GB, 8G EMMC, 4w T/S, Android