

Main Features

- 10.4" XGA TFT LCD panel
- Slim bezel and compact design
- Automatic/Manual brightness control
- Wide range power input from 9 ~ 36VDC
- Projected capacitive touch screen with multi-touch
- Support four CVBS inputs to connect rear view camera
- High brightness display for outdoor applications
- Compliant with IP65

Product Overview

VMD 3002 is a robust 10.4-inch TFT LCD monitor with enhanced brightness, projected capacitive touchscreen, and high performance loud speaker. It is designed with a single cable to consolidate power, display, and other control signal to ease the installation and secure the connection. It also features four analog video inputs to feed the real time video from the rear view cameras to the display. VMD 3002 mechanical design is compliant with IP65. With the 1000nits ultra high brightness display and adaptive brightness control, it is an ideal solution for in-vehicle and outdoor applications.

Specifications

General

- Enclosure: Plastic PC + ABS
- Mounting: Support VESA 75/100
- Power Input: 9 ~ 36VDC
- Power Consumption: 18W
- Ingress Protection: IP65
- Dimension: 256.5 x 202.1 x 31.5 mm
- Weight: 1.64Kg, 4.16Lb

LCD Panel

- 10.4-inch TFT LCD panel with LED backlight
- 1024 x 768 pixels (XGA)
- Brightness: 1200 cd/m² (typical, after touch screen is 1080cd/m²)
- Contrast Ratio: 500: 1 (typical)

Touch Screen Sensor

- Projected capacitive touchscreen
- Surface Hardness: 6H
- Multiple touch

I/O Interface-Front

- 1 x LED indicators (Power on/off, Auto Back-light, MCU update)
- IR remote sensor

I/O Interface-Lateral

- On screen display buttons x 7
 - Display power on/off
 - OSD Menu
 - Volume control (+/-)

- Brightness control (+/-)
- Auto Configuration

I/O Interface-Bottom

- Pigtail with multiple IO interface
 - 4 x CVBS connector
 - 1 x Line-in
 - 1 x VGA
 - 1 x USB
 - 1 x COM (TX/RX)
 - 1 x Power input connector (9 ~ 36VDC)

Environment

- Operating temperature: -30°C to 70°C
- Storage temperature: -30°C to 80°C
- Vibration (random): 2.5g@5 ~ 500 Hz
- Vibration
 - Operating: MIL-STD-810G, 514.6 Procedure 1, Category 4, Ground Vehicle – Highway Truck
 - Storage: MIL-STD-810G, 514.6 Procedure 1, Category 4, Integrity Test
- Shock
 - Operating: MIL-STD-810G, Method 516.6, Procedure I, Trucks and semi-trailers=20g
 - Crash hazard: MIL-STD-810G, Method 516.6, Procedure V, Ground equipment=75g

Standards/Certifications

- CE approval
- FCC Class B

Dimension Drawing

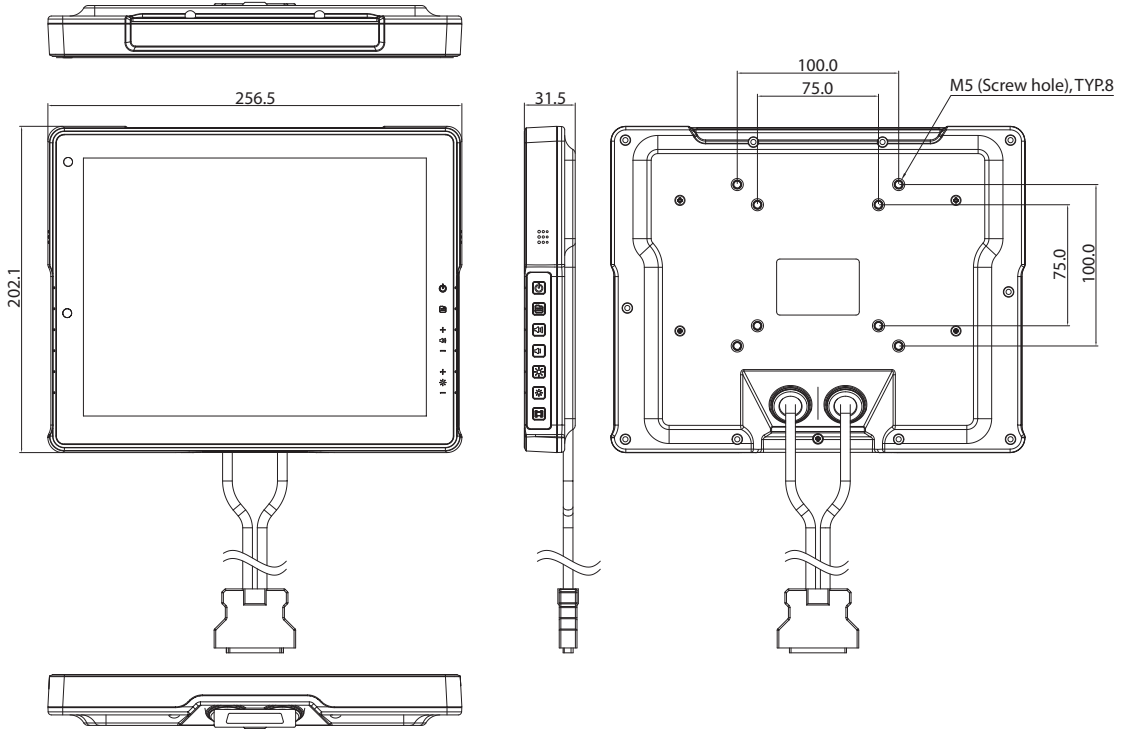

Ordering Information

- ♦ **VMD 3002-BS (P/N: 10VD0300200X0)**
10.4" XGA vehicle mount display with touch screen, VGA and CVBS Interfaces
- ♦ **Bundle Accessories**
External Pigtail Cable for Multi-I/O
Driver CD