

SCM5B48



Accelerometer Input Module

Description

The SCM5B48 provides excitation to piezoelectric sensors with built-in microelectronic amplifiers, commonly known as ICP®* or IEPE* or LIVM* sensors. The module provides a constant current excitation to the sensor, then isolates, filters, and amplifies the sensor output, yielding a high-level analog voltage output. The excitation current, signal gain, and filter high-pass and low-pass cutoff frequencies are field-configurable through a set of slide switches.

Six poles of signal filtering in the SCM5B48 module result in greater than 100dB of normal-mode rejection for signal frequencies above the cutoff frequency. One pole of filtering is on the field side of the isolation barrier for anti-aliasing purposes and the remaining five-pole programmable Bessel filter is located on the system side. High-pass filtering is achieved through a second order passive filter, located on the field side. If desired, the output switch can be turned on continuously by simply connecting pin 22, the Read-Enable pin, to I/O Common, pin 19.

The SCM5B48 offers the option of setting the constant current source for sensor excitation to common values of 4mA or 9mA with a compliance voltage of 24VDC. Programmable gains of 1, 10 and 100 are selectable and the module offers a ±10V output. The required supply level is +5VDC, ±5%.

To ensure protection of expensive data acquisition equipment, the SCM5B48 module signal inputs and sensor excitation outputs are protected against accidental connection of voltages up to 240Vrms.

► Features

- Interfaces to ICP®* or IEPE* or LIVM* Sensors
- ±10V Output Range
- 1500Vrms Transformer Isolation
- ANSI/IEEE C37.90.1 Transient Protection
- Input Protection to 240Vrms Continuous
- 1, 10, and 100 Programmable Gain
- 2.5, 5, 10, and 20kHz Programmable LP Filter
- 0.2 and 10Hz Programmable HP Filter
- 4mA or 9mA Programmable Current Excitation
- 100dB CMR
- ±0.2% Accuracy
- ±0.01% Linearity
- Low Drift with Ambient Temperature
- -40°C to +85°C Operating Temperature Range
- CE Compliant, CSA C/US Certification Pending
- Mix and Match SCM5B Types on Backpanel

*ICP is a registered trademark of PCB Group Inc.

*IEPE is Integrated Electronic Piezo-Electric

*LIVM is Low Impedance Voltage Mode

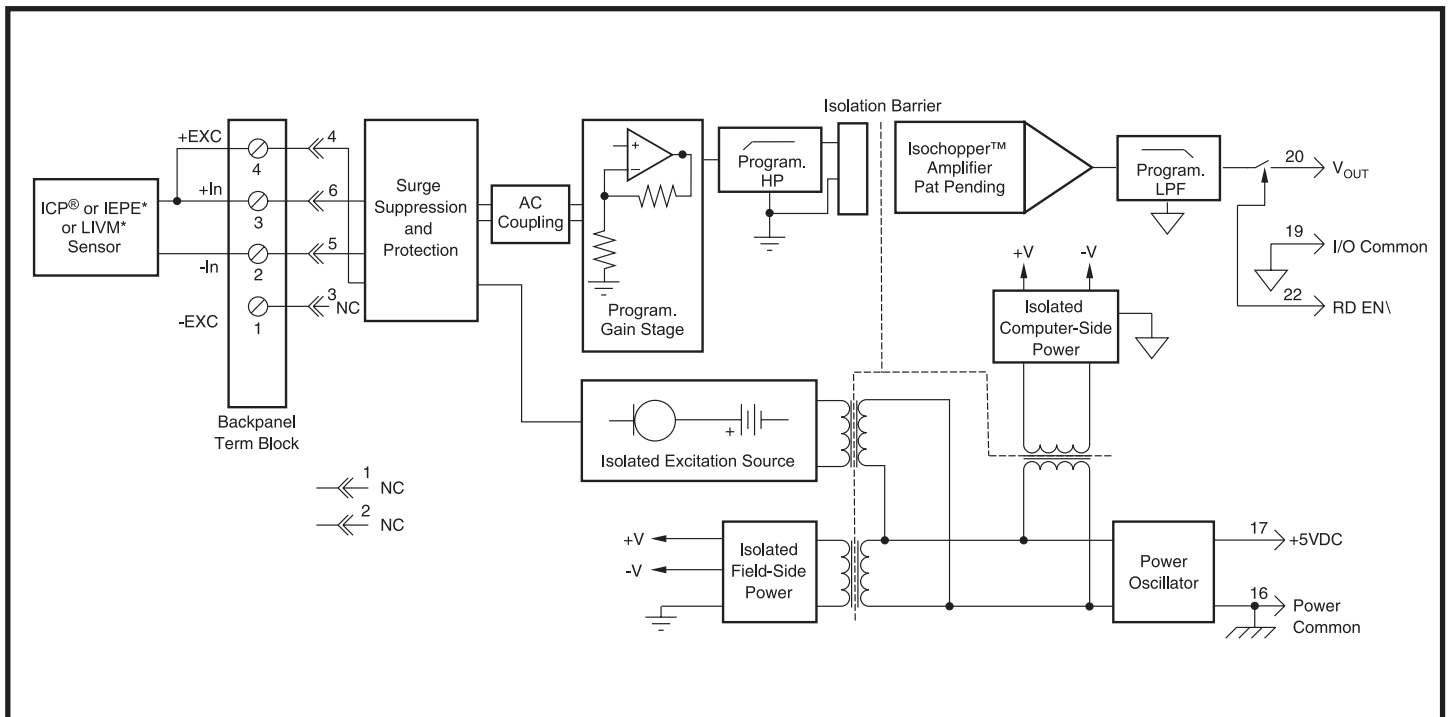

Figure 1: SCM5B48 Block Diagram

Specifications Typical at $T_A=+25^\circ\text{C}$ and +5V power

Module	SCM5B48
Input Type Range ⁽¹⁾ Protection Continuous Transient	Accelerometer $\pm 10\text{V}$ 240Vrms max ANSI/IEEE C37.90.1
Excitation Constant Current ⁽²⁾ Compliance Voltage Protection Continuous Transient	4mA or 9mA, $\pm 10\%$ 24V $\pm 10\%$ 240Vrms max ANSI/IEEE C37.90.1
Output Range Resistance Protection	$\pm 10\text{V}$ 50 Ω Continuous Short to Ground
Gain Programmable ⁽²⁾	1, 10, 100
CMR (50/60Hz) Accuracy ⁽³⁾ Linearity Stability Offset Gain Output Noise, Gain=1, BW=20kHz Low Pass Filter Type Programmable ⁽²⁾ High Pass Filter Programmable ⁽²⁾ CMV (Input to Output) Continuous Transient NMR	100dB $\pm 0.2\%$ Span $\pm 0.01\%$ Span $\pm 25\text{ppm}/^\circ\text{C}$ $\pm 100\text{ppm}/^\circ\text{C}$ 200 μVrms Bessel 2.5kHz, 5kHz, 10kHz, 20kHz DC, 0.2Hz, 10Hz 1500Vrms max ANSI/IEEE C37.90.1 100db per Decade above cutoff frequency
Supply Voltage Current	+5VDC $\pm 5\%$ 140mA (9mA excitation) 100mA (4mA excitation)
Mechanical Dimensions (h)(w)(d)	2.28" x 2.26" x 0.6" (58mm x 57mm x 15mm)
Environmental Operating Temperature Range Storage Temperature Range	-40°C to $+85^\circ\text{C}$ -40°C to $+85^\circ\text{C}$

NOTES:
 (1) AC peak for AC coupling. For DC coupling input range (AC + DC): 0 to +10V.
 (2) Programmable using slide switches on the bottom of the module.
 (3) Includes linearity, repeatability and hysteresis.

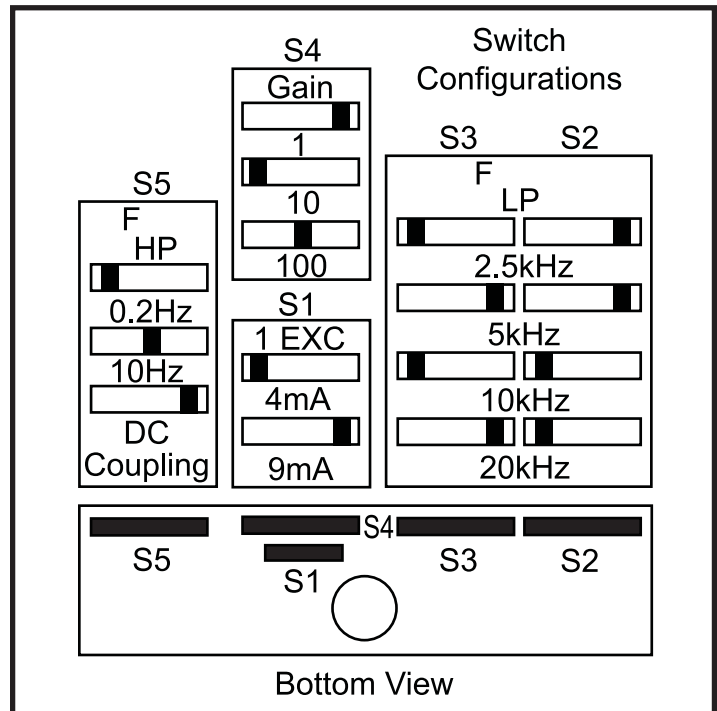

Figure 2: SCM5B48 Side Label

Ordering Information

Model	Input Range	Output Range	Bandwidth	Mechanical Format	Isolation Voltage (Vrms)
SCM5B48-01	$\pm 10\text{V}$ max ⁽¹⁾	$\pm 10\text{V}$	2.5kHz to 20kHz ⁽²⁾	Modular plug-in board	1500