

# TN-5508A/5516A Series

## EN 50155 8/16-port managed Ethernet switches



- > Isolated power with wide 24 to 110 VDC power supply range
- > Essential compliance with EN 50155\*
- > -40 to 75°C operating temperature range
- > Turbo Ring and Turbo Chain (recovery time < 20 ms @ 250 switches), and STP/RSTP/MSTP for network redundancy

\*Moxa defines "essential compliance" to include those EN 50155 requirements that make products more suitable for rolling stock railway applications.



EN 50155

EN 50121



### Introduction

The ToughNet TN-5500A series M12 managed Ethernet switches are designed for railway applications, such as rolling stock, and wayside installations. The TN series switches use M12 and other circular connectors to ensure tight, robust connections, and guarantee reliable operation against environmental disturbances, such as vibration and shock. The TN-5500A series Ethernet switches provide 8 or 16 Fast Ethernet M12 ports. In addition, the 24 to 110 VDC wide power input range and isolated dual power inputs not only allow you to use the same type of power source at different sites around the globe, but also

increase the reliability of your communications system. Furthermore, the -40 to 75°C operating temperature and IP54-rated waterproof enclosure allow deployment in harsh environments. The TN-5500A series Ethernet switches are compliant with essential sections of EN 50155, covering operating temperature, power input voltage, surge, ESD, and vibration, as well as conformal coating and power insulation, making the switches suitable for a variety of industrial applications.

### Features and Benefits

- IPv6 Ready logo awarded (IPv6 Logo Committee certified)
- Leading EN 50155-compliant industrial Ethernet switches for rolling stock applications
- DHCP Option 82 for IP address assignment with different policies
- Turbo Ring and Turbo Chain (recovery time < 20 ms @ 250 switches), and STP/RSTP/MSTP for network redundancy
- IGMP snooping and GMRP for filtering multicast traffic
- EtherNet/IP and Modbus/TCP industrial Ethernet protocols supported
- Port-based VLAN, IEEE 802.1Q VLAN, and GVRP to ease network planning
- QoS (IEEE 802.1p/1Q and ToS/DiffServ) allows real-time traffic classification and prioritization
- IEEE 802.3ad, LACP for optimum bandwidth utilization
- SNMPv1/v2c/v3 for different levels of network management
- TACACS+, SNMPv3, IEEE 802.1X, HTTPS, and SSH to enhance network security
- RMON for efficient network monitoring and proactive capability
- Bandwidth management prevents unpredictable network status
- Lock port allows access by only authorized MAC addresses
- Port mirroring for online debugging
- Automatic warning by exception through email, relay output
- Line-swap fast recovery
- LLDP for automatic topology discovery in network management software
- Configurable by web browser, Telnet/serial console, CLI, and Windows utility
- Loop protection prevents network loops
- Panel mounting or DIN-rail mounting installation capability

### Specifications

#### Technology

##### Standards:

- IEEE 802.3 for 10BaseT
- IEEE 802.3u for 100BaseT(X)
- IEEE 802.3x for Flow Control
- IEEE 802.1D-2004 for Spanning Tree Protocol
- IEEE 802.1w for Rapid Spanning Tree Protocol
- IEEE 802.1s for Multiple Spanning Tree Protocol
- IEEE 802.1Q for VLAN Tagging
- IEEE 802.1p for Class of Service

IEEE 802.1X for Authentication

IEEE 802.3ad for Port Trunk with LACP

**Protocols:** IGMPv1/v2, GMRP, GVRP, SNMPv1/v2c/v3, DHCP Server/Client, DHCP Option 66/67/82, BootP, TFTP, SNTP, SMTP, RARP, RMON, HTTP, HTTPS, Telnet, SSH, Syslog, SNMP Inform, LLDP, IEEE 1588 PTP v2, IPv6, NTP Server/Client, EtherNet/IP, Modbus/TCP

**MIB:** MIB-II, Ethernet-like MIB, P-BRIDGE MIB, Q-BRIDGE MIB, Bridge MIB, RSTP MIB, RMON MIB Group 1, 2, 3, 9

**Flow Control:** IEEE802.3x flow control, back pressure flow control

### Switch Properties

**Priority Queues:** 4  
**Max. Number of Available VLANs:** 64  
**VLAN ID Range:** VID 1 to 4094  
**IGMP Groups:** 256

### Interface

**Fast Ethernet:** Front cabling, M12 D-coded 4-pin female connector, 10/100BaseT(X) auto negotiation speed, F/H duplex mode, and auto MDI/MDI-X connection  
**Console Port:** M12 A-coding 5-pin male connector  
**System LED Indicators:** PWR1, PWR2, FAULT, MSTR/HEAD, CPLR/ TAIL  
**Port LED Indicators:** 10/100M (Fast Ethernet port)  
**Alarm Contact:** 2 relay outputs in one M12 A-coding 5-pin male connector with current carrying capacity of 1A @ 30 VDC

### Power Requirements

**Input Voltage:**  
 WV: 24 to 110 VDC (16.8 to 137.5 VDC)  
**Max. Input Current:**  
 TN-5508A series: 0.28 A @ 24 VDC; 0.07 A @ 110 VDC  
 TN-5516A series: 0.39 A @ 24 VDC; 0.09 A @ 110 VDC

**Overload Current Protection:** Present  
**Connection:** M23 connector  
**Reverse Polarity Protection:** Present

### Physical Characteristics

**Housing:** Aluminium alloy, IP54 protection (optional protective caps available for unused ports)  
**Dimensions:**  
 TN-5508A Series: 185 x 175.8 x 76.0 mm (7.28 x 6.92 x 2.99 in)  
 TN-5516A Series: 250 x 175.8 x 76.0 mm (9.84 x 6.92 x 2.99 in)  
**Weight:**  
 TN-5508A Series: 1,610 g  
 TN-5516A Series: 2,138 g  
**Installation:** Panel mounting, DIN-rail mounting (with optional kit: DK-DC50131)

### Environmental Limits

**Operating Temperature:** -40 to 75°C (-40 to 167°F)  
**Storage Temperature:** -40 to 85°C (-40 to 185°F)  
**Ambient Relative Humidity:** 5 to 95% (non-condensing)  
**Vibration:**  
 IEC 60068-2-6, 2-17.8 Hz: ±1.6 mm; 17.8-500 Hz: 2 g; 2 hours/axis  
**Shock:** IEC 60068-2-27, 20 g / 11 ms  
**Ingress Protection:** IEC 60529, IP54  
**Altitude:** Up to 2,000 m  
*Note: Please contact Moxa if you require products guaranteed to function at higher altitudes*

### Standards and Certifications

**Safety:** UL/cUL 508, EN 60950-1 (LVD)  
**EMC:** EN 55022, EN 55024  
**EMI:** CISPR 22, FCC Part 15B Class A  
**EMS:**  
 IEC 61000-4-2 ESD: Contact 6 kV; Air 8 kV  
 IEC 61000-4-3 RS: 20 V/m (80 MHz to 1 GHz)  
 IEC 61000-4-4 EFT: Power 2 kV; Signal 2 kV  
 IEC 61000-4-5 Surge: Power 2 kV; Signal 2 kV  
 IEC 61000-4-6 CS: 10 V  
 IEC 61000-4-8  
**Rail Traffic:** (for panel mounting installations)  
 EN 50155 (essential compliance\*), EN 50121-4, EN 50121-3-2, EN 45545-2  
*\* Please contact Moxa or a Moxa distributor for details.*

**Shock:** IEC 61373  
**Freefall:** IEC 60068-2-32  
**Vibration:** EN 50155, IEC 61373

### MTBF

**Time:**  
 TN-5508A series: 814,964 hrs  
 TN-5516A series: 722,721 hrs  
**Standard:** Telcordia SR332, GB, 25°C  
*Note: Please check Moxa's website for the most up-to-date certification status.*

### Warranty

**Warranty Period:** 5 years  
**Details:** See [www.moxa.com/warranty](http://www.moxa.com/warranty)

## Dimensions

### TN-5508A Series

Unit: mm (inch)

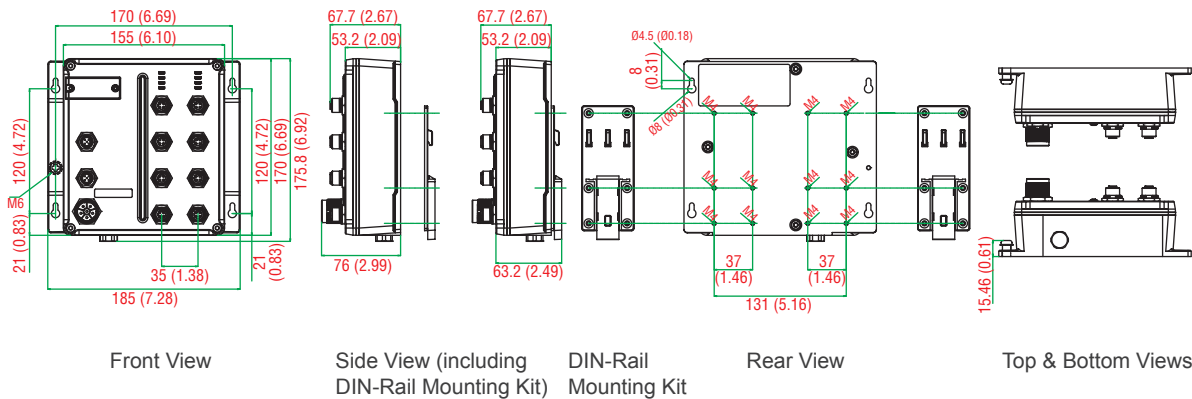

## Dimensions

Unit: mm (inch)

### TN-5516A Series

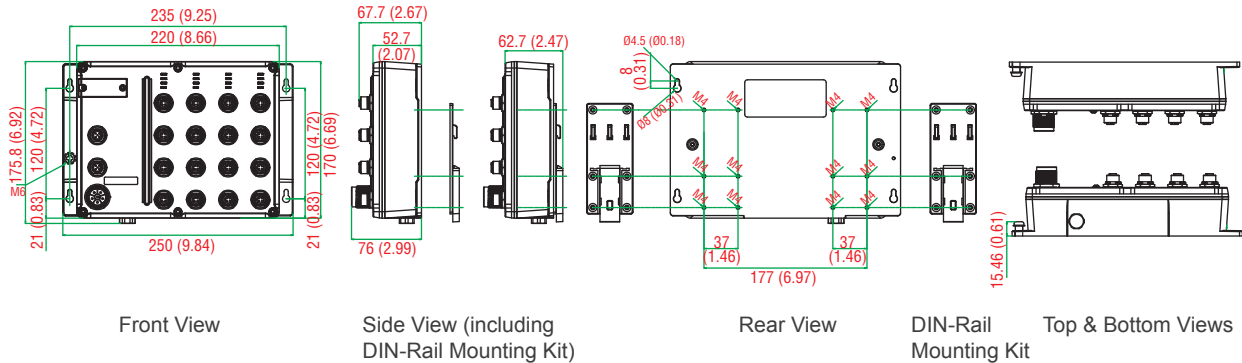

## Ordering Information

Available Models	Port Interface	Power Supply	Conformal Coating
Wide Temperature (-40 to 75°C)	10/100 BaseT(X), M12 connector	WV: 24 to 110 VDC (16.8 to 137.5 VDC)	
<b>TN-5508A Series</b>			
TN-5508A-WV-T	8	1 (dual inputs)	-
TN-5508A-WV-CT-T	8	1 (dual inputs)	✓
<b>TN-5516A Series</b>			
TN-5516A-WV-T	16	1 (dual inputs)	-
TN-5516A-WV-CT-T	16	1 (dual inputs)	✓

### Optional Accessories (must be purchased separately)

**Power Cords, M12/M23 Connectors, Protective Caps:** See following page

**MXview:** Moxa industrial network management software with 50, 100, 250, 500, 1000, or 2000 nodes

**EDS-SNMP OPC Server Pro:** OPC server software that works with all SNMP devices

**ABC-01-M12:** Configuration backup and restoration tool for TN series managed Ethernet switches, 0 to 60°C operating temperature

### Package Checklist

- TN-5500A switch
- M12-to-DB9 console port cable
- 2 protective caps for console and relay output ports
- Panel mounting kit
- Documentation and software CD
- Hardware installation guide
- Warranty card

# EN 50155 Switch Accessories

## : M12/M23 Power Cords

### **CBL-M12D(MM4P)/RJ45-100 IP67**

1-meter M12-to-RJ45 Cat-5C UTP Ethernet cable with IP67-rated 4-pin male D-coded M12 connector



### **CBL-M12(FF5P)/OPEN-100 IP67**

1-meter M12-to-5-pin power cable with IP67-rated 5-pin female A-coded M12 connector



### **CBL-M23(FF6P)/Open-BK-100 IP67**

1-meter M23-to-6-pin power cable with IP67-rated 6-pin female M23 connector



## : M12 Connectors

### **M12D-4P-IP68**

Field-installable M12 D-coded screw-in sensor connector, 4-pin male, IP68-rated



### **M12A-5P-IP68**

Field-installable M12 A-coded screw-in sensor connector, 5-pin female, IP68-rated



## : M12 IP67 Protective Caps

### **A-CAP-M12F-M**

Metal cap for M12 female connector



### **A-CAP-M12M-M**

Metal cap for M12 male connector

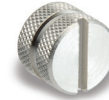

## : M23 Connectors

### **A-PLG-WPM23-01**

M23 cable connector, 6-pin female, crimp type

